

# C++ APPLICATION FOR PLANNING DIDACTIC ACTIVITIES

Mihai ANASTASIEI

“Nicolae Bălcescu” Land Forces Academy, Sibiu

ccyberr96@gmail.com

Scientific coordinator: Assoc.Prof. Romana OANCEA, PhD

**Abstract:** *Planning the teaching activities is a challenge for all educational institutions that manage many fields of study and have a large number of students. At this moment in time exist a vast and diverse range of commercial applications that designs timetables, but the specific of the institution, the number of students and professors, classroom restrictions or availability restrictions cannot be generalized or treated in the same way. The application for planning the timetable of didactic activities in an educational institution, implemented in C++, tries to treat differently a series of restrictions that may appear.*

**Keywords:** timetable, restriction, C++ application

## Introduction

The purpose of this paper is to describe an application that solves the problem of generating a university schedule. The application is made using Visual Studio IDE using C++ language.

So this paper contains:

- the restrictions to be taken into account in the process of generating the university timetable;
- the constraints and preferences of the generation of the schedule which is the starting point of the generation process;
- the conceptual model of the application.

## 1. Restrictions

The restrictions, which must be taken into account in order to achieve optimal conditions of the application, are the following:

The format of the input data that must meet the following set of conditions:

In a folder, which can also be created through the application, you will find 6 text document files, each of them having the following names: dispoibilitate.txt, grupe.txt, laboratoare.txt, profesori.txt, sali.txt, specializari.txt. This will be shown in the figure below.

Name	Type
dispoibilitate	Text Document
grupe	Text Document
laboratoare	Text Document
profesori	Text Document
sali	Text Document
specializari	Text Document

**Figure 1. Folder with input data files**

The file grupe.txt will have the following structure: each group will have on its first line its name, on the second line the name of the specialization to which it belongs, and on the third line will be the number of students it has. The 5th character in the group name will indicate its year.

A representation of this file will be presented in the figure below.

```

grupe - Notepad
File Edit Format View Help
G12_1
Specializare_1
15
G12_3
Specializare_4
21
G22_2
Specializare_2
30
G12_2
Specializare_3
30
G11_1
Specializare_3
30
G21_3
Specializare_4
20

```

**Figure 2.grupe.txt file**

In the file diponibilitate.txt will be found, on independent lines, the name and surname of the teacher, as well as the days when it is unavailable.

The figure below contains an example of this file.

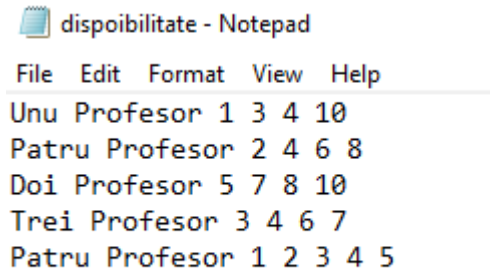

```
dispoibilitate - Notepad
File Edit Format View Help
Unu Profesor 1 3 4 10
Patru Profesor 2 4 6 8
Doi Profesor 5 7 8 10
Trei Profesor 3 4 6 7
Patru Profesor 1 2 3 4 5
```

**Figure 3.dispoibilitate.txt file**

The format of the specializari.txt file is the following: each specialization contains on its first line its name, on the second line the year of the groups that are part of the respective specialization, and on the following lines are the subjects included in the specialization program. Each subject is found on an independent line as follows: the name of the subject followed by the number of courses, the number of seminars, and the number of laboratories to be held. The last subject that is included in the respective specialization will contain at the end of the line the character "\*".

An example of this file can be found in the figure below.

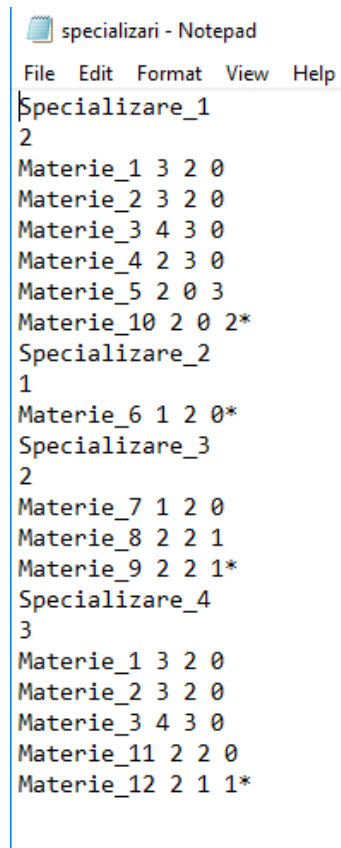

```
specializari - Notepad
File Edit Format View Help
Specializare_1
2
Materie_1 3 2 0
Materie_2 3 2 0
Materie_3 4 3 0
Materie_4 2 3 0
Materie_5 2 0 3
Materie_10 2 0 2*
Specializare_2
1
Materie_6 1 2 0*
Specializare_3
2
Materie_7 1 2 0
Materie_8 2 2 1
Materie_9 2 2 1*
Specializare_4
3
Materie_1 3 2 0
Materie_2 3 2 0
Materie_3 4 3 0
Materie_11 2 2 0
Materie_12 2 1 1*
```

**Figure 4.specializari.txt file**

The teacher.txt file contains two lines for each teacher as follows: the first line contains the teacher's name and surname, and the second line contains the maximum number of modules and the names of the subjects that the teacher teaches, each separated by a space.

An example of this file can be found in the figure below.

```
profesori - Notepad
File Edit Format View Help
Unu Profesor
20 Materie_1 Materie_2
Doi Profesor
30 Materie_1 Materie_2 Materie_3
Trei Profesor
30 Materie_4 Materie_5 Materie_6
Patru Profesor
12 Materie_7 Materie_8
Cinci Profesor
20 Materie_9 Materie_10
Sase Profesor
20 Materie_11 Materie_12
```

**Figure 5.profesori.txt file**

The file sali.txt contains two lines for each room, each room name, on the first line, and on the second line the number of seats available.

The figure below shows the file sali.txt.

```
sali - Notepad
File Edit Format View
S_1
50
S_2
100
S_3
30
S_4
15
S_5
30
S_6
20
```

**Figure 6. Sali.txt file**

The laboratories.txt file contains for each specialized room: on the first line the name of the respective room, and on the second line the number of available places followed by the materials that can be carried out in the respective room, each separated by a space.

The following figure contains an example of this type of file.

```
laboratoare - Notepad
File Edit Format View Help
L1
25 Materie_1 Materie_2 Materie_3

L2
25 Materie_4 Materie_5

L3
25 Materie_6 Materie_7

L4
30 Materie_8 Materie_9

L5
50 Materie_10
```

**Figura 6.laboratoare.txt file**

The number of days for which the application generates a schedule is 10;

The maximum number of modules for a single day is 5;

All subjects that have laboratory modules must have a specialized room, and the number of available seats in a laboratory room must be at least equal to the number of students in the largest group who carry out their laboratory time in that room;

In order for a room to be used the number of places available from it must be at least equal to the group with the lowest number of students;

In order for a course to be held in a classroom, the number of places available in it will be at least equal to the total number of students in a specialty.

### **2.1. Hard constraints**

The most important rules to be followed in the process of automatically generating a university schedule are expressed by hard constraints and are the following:

Not to allocate at the same time slot a laboratory or seminar from the same subject with a single teacher to two different groups. This is achieved by using bool availability matrices for teachers, student groups and classrooms;

The number of students running a module should not exceed the maximum number of seats available in a room. This constraint is solved by the implementation of functions that ensure that the maximum number of seats is not exceeded;

The laboratories will only be held in specialized rooms. Each specialized room, within its class, contains the subjects that have the possibility to take place.

Teachers who are not available on some days, they will not have allocated modules on those days. This type of constraint is solved by passing all time slots in the availability matrix on the respective days as unavailable.

### **2.2. Soft constraints**

Soft constraints are less important rules that can be violated, but trying to comply with them as much as possible. These are the following:

On the same day there should be no modules of the same type one after the other. The allocation of time slots is done first on days and then on modules and thus partial avoidance of assigning a module on the same day is avoided.

In one day, as few modules as possible for any study group or teacher will be allocated. The time slots are passed from the first day to the last mode the last day, the first time the day is changed.

There should be no course modules on Fridays. The courses are assigned during the first 4 days of the week.

Modules should be assigned evenly over the 2 weeks. The courses are planned intermittently between 2 weeks, and the laboratories and seminars are planned according to the courses.

Seminar / laboratory modules should not be planned before the courses. This is solved by using a course search function.

### 3.The conceptual model

The application generates a university schedule for 2 weeks with 10 days available, from Monday to Friday, with a maximum of 5 modules in a single day.

The application contains the following buttons:

- the New Base button which is created to create a file folder with the format described in point 1;
- the Open Base button is meant to open a folder containing files with the format described in point 1, if the format is incorrect an error will appear;
- Edit button with the purpose of modifying an open or created database;
- The Run button has the role of generating a schedule;
- the Schedule View button will display a created schedule;
- the Look button by pressing it can search the timetable of a teacher or a group of students.

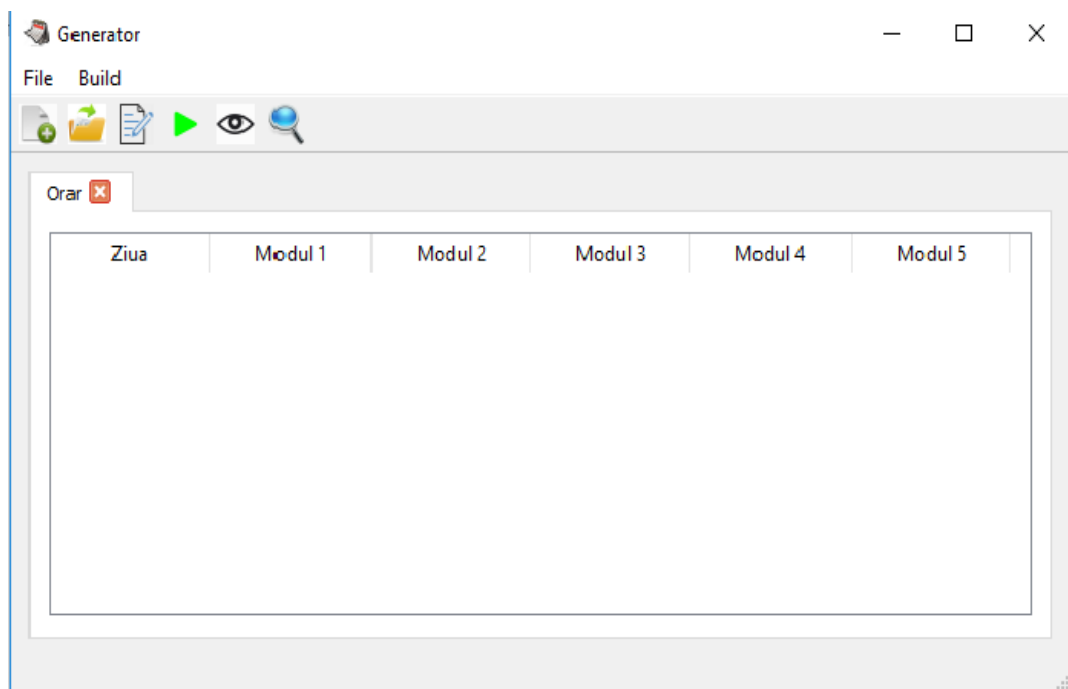

Figure 7.Application interface

Ziua	Modul 1	Modul 2	Modul 3	Modul 4	Modul 5
1 Ziua			<b>Doi Profesor</b>		
2 Luni	Materie_1 S_2 C Ga2_2 Gb2_2 G12_2	Materie_3 S_2 C Ga2_2 Gb2_2 G12_2			
3 Marti			Materie_1 L1 L Gb2_2	Materie_3 L1 L Ga2_2	Materie_3 L1 L G12_2
4 Miercuri	Materie_2 S_2 C Ga2_2 Gb2_2 G12_2		Materie_1 L1 L Ga2_2	Materie_3 L1 L Ga2_2	Materie_3 L1 L G12_2
5 Joi	Materie_3 S_2 C Ga2_2 Gb2_2 G12_2		Materie_2 L1 L Ga2_2	Materie_3 L1 L Gb2_2	

**Figure 8. Individual schedule of an instructor**

Figure 8 shows the individual schedule of an instructor. It contains all the activities planned over the 2 week period. The name of the instructor is marked by the use of a red outline. A planned activity contains: the name of the subject matter, its place of activity, the type of activity and the group / groups that support this activity.

Ziua	Modul 1	Modul 2	Modul 3	Modul 4	Modul 5
1 Ziua			<b>Gb2_2</b>		
2 Luni	Materie_1 C Doi S_2	Materie_3 C Doi S_2			
3 Marti	Materie_1 C Unu S_2	Materie_4 C Trei S_2	Materie_1 L Doi L1		
4 Miercuri	Materie_2 C Doi S_2	Materie_5 C Trei S_2		Materie_4 L Trei L2	
5 Joi	Materie_3 C Doi S_2	Materie_10 C Cinci S_2	Materie_5 S Trei S_3	Materie_3 L Doi L1	

**Figure 9. Individual schedule of a students group**

Figure 9 contains the individual schedule of a group of students containing all the planned activities. The group is marked by using the red outline. A planned activity contains: the name of the subject, the type of the subject, the name of the teacher conducting the activity and the place of conduct.

## Conclusion

Automatic generation of the schedule, although it is a job that requires solid programming knowledge, leads to reduced planning time and plus it leads to reducing staff burden on this task.

The problem of solving the bakery of a schedule is fulfilled, within this works, by using an algorithm to solve the constraints and through the search for suitable time slots.

## **BIBLIOGRAPHY**

Michael Marte, *Models and Algorithms for School Timetabling –A Constraint-Programming Approach*, Munchen, Fakultat fur Mathematik, Informatik und Statistik der Ludwig-Maximilians- UniversitatMunchen, 2002.

Tomáš Müller. *Constraint-based Timetabling*, Praga, Charles University in Prague, 2005.

Tomáš Müller, Keith Murray, Hana Rudova, *Modeling and Solution of a Complex University Course Timetabling Problem.*, Brno, Masaryk University Botanicka, 2016.



# STUDY ON THE USE OF THE E-CONTENT DOMAIN

Narcis-Claudiu ANECHITEI  
“Nicolae Bălcescu” Land Forces Academy, Sibiu  
c.anechitei@gmail.com  
Scientific coordinator: Assoc.Prof. Romana OANCEA, PhD

**Abstract:** *This article presents a study on the use of the e-content domain. The e-content domain is an integrated set of interactive online services that provides learners and others involved in education with information, tools and resources to support and improve teaching and management of education. Developers use numerous tools throughout the creation, construction and testing of software codes. Development tools often include text editors, code libraries, compilers, and test platforms. Without an e-content platform, a developer must select, implement, integrate and manage all of these tools separately. An e-content platform brings together many of these development tools as a single framework, application or service. The integrated toolkit is designed to simplify software development and can identify and minimize coding errors and typing errors.*

**Keywords :** e-content, education, software development.

## **Models of e-content development**

The e-content development models are available in five different ways and they are as follows:

- 1) An instructional design model defined nine different components and adopted a continuous update with evaluation;
- 2) Teaching of media in a systematic approach model compared the different instruction design models;
- 3) A Systematic Design of Instruction model described all the phases of process starts with instructional goals and ends with summative evaluation;
- 4) Systems Reusable Information Object Strategy ;
- 5) Content based model explained the learning objectives of a content and the contents accessibility and reusability.

## **Phases of e-content development**

E-content development aspects consists of six phases:

- analysis;
- design;
- development;
- testing;
- implementation;
- evaluation.

**The Analysis Phase:**

- Identify target audience.
- Identify the object of art history course.
- Identify delivery method.

**The Design Phase:**

- The design of learning solution.
- Plan e-content in subject preparation.
- The implementation of software (powerpoint, flash).
- The use of creative and innovative of subject content (related images, limited use of text, a lot of attractive images).

**The Development Phase:**

- Expanding the e-content design.
- Linking the e-content to blog, websites etc.
- Implementing interactive button to achieve two-way interactive relationship between educators and students.

**The Testing phase:**

- Pre-introduction to subject syllabus.
- Testing the spells mistakes.
- Suitability of content.
- Clarify of images.
- Audio and video appropriateness.
- Timing involving animation as the part of the content.

**The Implementation Phase:**

- Focusing on how to install the e-content through e-learning.
- Student's difficulties experienced while using e-content will be recommended for future improvement.
- Help to check the e-content accuracy and quality maintenance.

**The Evaluation Phase:**

- Collecting feedback from both learners and instructors.
- Based on the feedback, e-content will be develop again for more effective results on future.

**Pedagogical Issues in e-Content Development**

The development of the media, in general, and the new information and communication technologies (ICT) in particular, has been accompanied by continuous attempts to use them in education, their problematic complexity increasing proportionately. A longitudinal analysis of the impact of media in education indicates an exponential acceleration consistent with the development of the Internet and the communication and interaction techniques offered by it (hypertext, email, chat, video conferencing). Their implications in the educational plan are not limited to the issues of communication, but they transform to a deep level the nature of the educational process. The potential of new ICT's is even greater as their qualities converge with the change of the traditional paradigm (centered on teaching) towards an educational paradigm centered on learning, on student. In contrast to the more restrictive form of learning organization on classes, where they do not all belong to a class "having" similar academic or professional interests, ICT means allow the creation of mechanisms for associating students with common interests and the possibility of building common sense and sharing knowledge.

This fact requires the relevant science answers to education sciences in terms of efficiency, effectiveness, appropriate ways of designing and using virtual learning environments.

The new emergent socio-educational reality through the Internet gives the term of Virtual Learning Community (VLC) an increasingly consistent legitimacy.

VLC presents a series of characteristics that recommend them as suitable learning environments in the context of the new paradigm of student-centered education, as well as the communication, authority and legitimacy relationships between members, the level of expertise and involvement; goals are assumed leading to intrinsic motivation.

The informational content of the training courses will continue characterized by addressing the problematic aspects of :

- current trends of the development of education at global and national level (theories, researches, experiences, innovations relevant in the fields: pedagogical, psychological, managerial, social, etc.);

- education focused on the learner (with emphasis on child development as the subject of one's own development, interrelation in early education; educational inclusion, enhancing the learning environment and the child's experience);

- quality management (evaluating, monitoring, designing, organizing, coordinating the educational process; the efficiency and effectiveness of the educational process; capitalizing on opportunities to improve the educational context and process; motivating and involving the family and community in the educational process, etc.);

- career design / scientific professionalization / guidance in professional development (aspects of self-evaluation and reflection on one's own activity);

Teachers working in lifelong learning institutions should have appropriate recommendations, knowledge and experience, demonstrate an understanding of adult learning and learning-centered principles, have a career guidance system, the necessary skills and sufficient for the organization of continuous constructivist training of teachers.

### **Characteristics of e-content development**

E-content is based on some characteristics: effective program management, needs assessment, alignment, goals and metrics, relevancy, creativity, must be computer controlled and the information held must be represented digitally.

Theoretically, there is a difference between project and program, though most of the time this notions are used with equivalent meanings. In project management, a program contains more projects, and a project can be split down into subprojects, groups of actions and activities in order to be easier to manage.

On the other hand, the program is also regarded as a group of interdependent projects managed in a coordinated / concerted manner in order to obtain results that would not be possible for the individual project to take on their own.

Creating strategies, methodologies and technologies for the progress and circulation of e-learning contents is a step forward to make sure that all the people around the world have access to a highly quality of e-learning contents.

Teachers who are most interested in e-learning and virtual education, encourage the student to ask questions about how they care and learn about the activities they carry out in school in order to become an expert in learning. With the help of a well-planned learning environment, students learn how to learn.

The training program may target at developing varying sets of skills:

- cognitive skills, which can involve knowledge and comprehension, following instructions, as well as applying methods in new situations to solve problems.

- interpersonal skills;

- psychomotor skills, involving the acquisition of physical perceptions and movements.

### **AeL E-Content virtual library**

Advanced eLearning (AeL) is a product that supports three major by-products. It's about AeL as platforms and here we have learning platforms dedicated to mass education, pre-university, university education and a platform dedicated to companies that invest in computer-assisted education that invest in e-learning within the company and I mean big companies here, with thousands of people.

The second is interactive multimedia educational content and is developed in Romania on very clear pedagogical principles and which also has several types of content. We have educational content for pre-university education that is based on RLOs (Reusable Learning Objects), that is, those very atomized elements that are subject to an operational objective.

The electronic lessons developed for the Romanian primary, secondary and high school education - 3578 lessons, totaling 16,000 individual moments, consisting of over 45,000 learning items - are designed to support the didactic process in the classroom. These correspond to the formal curriculum for ISCED level 1,2,3, contributing significantly to a better approach to the contents and the process of instruction by the teacher, as well as to the development of key competences in students.

The content of an electronic lesson combines various learning items such as: interactive text, charts and maps, simulations, interactive experiments, exercises, quizzes and educational games. All the moments of lesson realized involve the direct activity of the students, and the interactivity consists mainly in the gradual feedback offered to the user throughout the lesson.

The impact studies conducted during the introduction of these educational software in the Romanian school, especially reveal the progress of all students in learning, with comparable results, regardless of their initial level.

Using computer-assisted AeL lessons, teachers have all the elements needed for a dual approach, which maintains a careful balance between the processes of knowledge - learning - and the products of knowledge - information.

Performance learning is due to the design of electronic lessons that allows:

- multisensory stimulation in presenting information;
- activities of individual information exploration / search and operation on it;
- exchange of information and cooperation in solving some work tasks;
- stimulating critical thinking;
- goal-oriented learning (operationally defined objective);
- increased chances of adjustment in relation to characteristics and self-knowledge.

### **Conclusion**

We need innovative work in electronic content materials as a form of digital literacy in educational environments, especially to analyze the implications of new forms of social network, knowledge split and knowledge creation. And ultimately, due to the ubiquitous type of electronic content as digital technology, the commercial interest that is invested in it, and the mostly unregulated content of Internet-based sources; also, we need to start by sketching out what a critical digital literacy might view.

Success in e-learning implies a wide understanding of content evolution processes. Current content developments include the increase significance of dynamic and interactive representations of multimedia components.

The Internet has changed everything. However, the potential of digital learning has not yet been fully realized. Nowadays, there are many challenges associated with digital learning that could hardly have been imagined a few decades ago. Latest technological innovations have created numerous new opportunities to better work for traditionally disadvantaged learners. Perhaps the most important benefit of digital learning tools is the ability to personalize learning.

Even if the technology is constantly evolving, it is necessary to optimally structure the use of these digital tools. Some of the challenges that these new learning pathways must face are:

- the motivation of the students;
- social abilities.

It is necessary to be aware that technologies can be either substitutes or additions to the resources that already exist in the school. To the extent that they are substitutes, they are equally equal forces.

Instruments for learning and teaching may include software for editing digital materials (for example, audio, video) and platforms for collaborating and sharing resources. Many tools that are designed for other areas of education, or which are not special for educational purposes, are, however, suitable for language education.

Varying theories of multimedia learning have been integrated to construct an successful study base to improve the programming of the learning computer and to lessen the cognitive overload that occurs due to the kind of the topic and the deficient training forms.

### **BIBLIOGRAPHY**

R. E. Mayer, "Introduction to Multimedia Learning," In: Mayer, E. (Ed), *The Cambridge handbook of multimedia learning*, 2005,pp.1-16.

Vijayakumari, G (2011) Role of Educational games improves meaningful learning, *Journal of Educational Technology*, I-manager pub, Vol. 08, No.02, July –Sep 2011, pp.08-11.

Selinger, M. (2004). Cultural and pedagogical implications of a global e-learning programme. *Cambridge Journal of Education*, Vol.34, No.2., pp. 213-229.

A.Nagy, "The impact of e-learning," In *E-Content*, Springer Berlin Heidelberg, 2005, pp.79-96.

R. C. Clark, and R. E.Mayer, *E-learning and the science of instruction: Proven guidelines for consumers and designers of multimedia learning*, John Wiley & Sons, 2011.

# MODIFYING LSB STEGANOGRAPHIC ALGORITHM TO PRODUCE BETTER RESULTS

Alexandru BĂNICĂ

"Nicolae Bălcescu" Land Forces Academy, Sibiu

alex\_acdc\_banica@yahoo.com

Scientific coordinator: Assoc. Prof. Dr. Romana OANCEA, PhD

***Abstract:** Steganography is the science deals with how communication can be disguised in seemingly harmless objects or images, representing an alternative to the use of cryptography, which is the science of transforming the content of the communication and making it obscure. In this paper a brief comparison between steganography and cryptography is made, highlighting the main differences between them. The practical part of the paper involved the realization of an application in Matlab in which we implemented an algorithm to hide secret information in an image. In the next step the algorithm was modified, making it much more difficult to detect the transmitted information and increasing the security.*

**Keywords:** Steganography, cryptography, LSB, steganalysis.

## I. INTRODUCTION

Steganography is the art of hiding information in objects or images that seem harmless. At present, steganography is being used more and more, experiencing an exponential development. The purpose pursued by using this technique is to mislead a possible eavesdropper, through the impossibility of distinguishing ordinary objects from those that hide a secret information.

Due to the multiple situations in which steganography can be used, there are many applications through which it is implemented. Obviously, there have been different techniques that try to discover the hidden messages by using this technique. The science that deals with breaking steganography algorithms and discovering files that hide other secret messages is called steganalysis.

## II. COMPARISON BETWEEN STEGANOGRAPHY AND CRYPTOGRAPHY

At present, steganography has become a powerful alternative to the use of cryptography. Even if the purpose of the two methods is largely the same, namely the transmission of a secret message, due to the different way of working, a short comparison can be made between cryptography and steganography.

First of all, it should be mentioned that steganography does not change the message structure. On the other hand, cryptography modifies the information before transmitting it.

A major difference between the two techniques is the fact that, in the case of cryptography, the encrypted message is visible to a possible interceptor, whereas, in the case of steganography, only its transmitter and receiver know. From this point of view, we can say

that steganography benefits from the lack of "unwanted" attention that can be given to the transmitted information.

On the other hand, when we talk about the principles and ways of ensuring the security of computer systems and networks, cryptography can be applied in most cases. This can be used to ensure data confidentiality, data integrity, and availability. Also, this is used to implement non-repudiation assurance mechanisms as well as in the authentication process. From this point of view, about steganography we can say that it is used only to ensure confidentiality.

From the point of view of the countermeasures, these are different from the two secretion techniques. For finding hidden messages, steganalysis uses techniques such as data exchange monitoring, searching for traces of manipulation and for structural oddities and data sanitization. For example, the detection of steganographed images can involve several stages:

- examining the size of the image
- color palette examination;
- searching for the latest changes;
- statistical analysis
- the analysis of coefficients of the discrete cosine function.

In order to break encrypted messages, cryptanalysis mainly uses reversible engineering algorithms.

### III. IMAGE STEGANOGRAPHY

There are several steganographic methods. Some of them involve creating a file based on the information in the hidden message, others involve searching for the ignored areas in certain files and inserting the secret information in these places, while others look for the insignificant information in the files and replace it with the secret message. The last one is also the most used. One of the most popular and simplest method for steganography is called Least Significant Bit (LSB) encoding.

This method can be used, for example, to hide a text in an image. This steganographic technique exploits the weakness of the human eye that cannot distinguish very small variations in color shades.

Assuming that the first letter of the encrypted text is A we can use three pixels to hide this letter, because each pixel is encoded using three bytes.

Suppose that the selected pixels have the following binary form:

11111000	11101001	00011100
11101001	11101011	00011010
11111011	11101001	01010101

The hidden message is 01000001 (letter A).

This method involves changing the least significant bits from the information that represents the pixels of the image with bits forming the secret message. This results in the next string of bits:

1111100 <b>0</b>	1110100 <b>1</b>	000111 <b>0</b> 0
1110100 <b>0</b>	1110101 <b>0</b>	0001101 <b>0</b>
1111101 <b>0</b>	1110100 <b>1</b>	010101 <b>0</b> 0

Bits represented in bold form the secret message, and those with underlined writing are, in fact, the only ones modified.

Bearing in mind that in binary we have only two values, the probability is that only 50% of the bits that make up the hidden message will be modified. In this example, it was necessary to modify only three of the eight bits needed to hide the secret message.

When the image is reconstructed with the changed bits, the difference in shade is not detectable for the human eye.

The main advantages of using this technique are:

- ease of implementation;
- the file size is not changed.

But there are some disadvantages:

- the same program should be used to hide and extract information;
- if the image is processed or compressed, the message may be lost;
- because the method is well known, there is a chance that someone will find out the secret message.

#### IV. IMPLEMENTING STEGANOGRAPHY

The practical part of the paper involved, in a first phase, the realization of an application in Matlab in which was implemented Least Significant Bit (LSB) encoding and decoding.

Because this steganographic method is well known, in the next step the algorithm was modified, making it much more difficult to detect the transmitted information and increasing the security.

Thereby, the application was modified so that it will be harder to detect the secret message. First, steganography will be combined with encryption and, before encoding the message using the LSB method, it will be encrypted. For encryption was implemented Caesar cipher.

After that, the algorithm was modified so that the secret message is not hidden in successive pixels, using a multiplication factor. This factor depends on the length of the image and the length of the secret message in bites. Also, this factor is chosen so that the number of modified bits is minimal.

Obviously, from a visual point of view, the human eye cannot see differences between the initial image and the one that hides the secret message. One example of steganography using the combined cod is illustrated in figures 1 and 2.



(Figure 1. Original image)



(Figure 2. Embedded image)

In the left side is the original cover image, where in the right side goes embedding a combined encrypted text into the cover image making it a steganographic image.



## **V. CONCLUSION**

Steganography is an efficient method of hiding secret information and a reliable alternative to cryptography. This technique has the advantage of being able to be implemented relatively easily and difficult to detect.

In this paper, a comparison was made between cryptography and steganography, highlighting the advantages and disadvantages of each of them. Next, one of the simplest techniques used in steganography has been presented, namely Least Significant Bit encoding.

Because the method is well known and there is a chance that someone will find out the secret message, the practical part of the paper involved the realization of an application in Matlab in which this method has been combined with cryptography. Thereby, it will be harder to detect the transmitted information and the security was increased.

## **BIBLIOGRAPHY**

Ronak Doshi, Pratik Jain, Lalit Gupta, Steganography and Its Applications in Security, International Journal of Modern Engineering Research, 2012;

Jessica Fridrich, Steganography in Digital Media - Principles, Algorithms and Applications, Cambridge University Press, 2010;

I. Avcibas, M. Kharrazi, N. D. Memon, and B. Sankur, Image steganalysis with binary similarity measures, EURASIP Journal on Applied Signal Processing, 2005;

J. Bierbrauer and J. Fridrich, Constructing good covering codes for applications in steganography, LNCS Transactions on Data Hiding and Multimedia Security, 2008;

G. Cancelli and M. Barni, MPSteg-color: A new steganographic technique for color images, 2007.

# AUGMENTED REALITY APPLICATIONS FOR TRAINING PURPOSES

Andrei-Alexandru BUȘĂ  
“Nicolae Bălcescu” Land Forces Academy, Sibiu  
andreialexandrubusa@gmail.com  
Scientific coordinator: Eng. Radu PETRUSE, PhD

**Abstract:** *Within this research paper we propose to study the implication of Augmented Reality (AR) for training purposes. In order to achieve this, we started with a study on AR technology evolution from the first application to the latest advances. Further we perform a literature review with the aim to identify the state of the art of AR applications for training purposes. In this review we searched in several scientific databases and research communities. Based on the results identified in the state of the art we extracted and analyzed the researches and/or use cases and organized them into three main categories. From these categories we extracted the common features which are present in AR applications, which we also conclude that are the most important features that an AR application must accomplish in order to be useful. In conclusion we present our findings, structured in a “best practice” guide for AR training applications development.*

**Keywords:** Augmented reality, Augmented reality applications, Military training

## 1. Introduction

The objective of this paper is to bring guidelines on the applications of Augmented Reality for military training purposes and the current and future trends of this technology. This technology aims to simplify the user’s life by providing easy access to virtual information at any time, but not only that, it can be capable of enhancing the user’s approach and cooperation with the real world, which concludes to great advantages in different fields like military, medical education, rehabilitation engineering, automotive safety and others [1].

Augmented Reality (AR) is a system capable of combining real and virtual items in a real environment, that can run interactively and in real time and can coordinate real and virtual items with each other [1].

Based on the results identified in the state of the art we extracted and analysed the researches and/or use cases and organised them into three categories as follows: Highest impact use cases; Best practices; Best results [1].

The beginnings of Augmented Reality dates back to the 1950s when a cinematographer, Morton Heilig, saw the movies as an opportunity to draw the viewer attention into visual effects that can’t be replicate in the real life. In 1962 he built a computer, named Sensorama, which prototype was described as “The Cinema of the Future”, which anticipated digital computing. In 1966 Ivan Sutherland created the head mounted display and in 1968 he was the primary one to construct an augmented reality system using an optical see-through head-

mounted display. Next, Myron Krueger designs the Videoplace, a room where it is possible for the users to interact with virtual items [2].

The Augmented Reality became later a method to help workers assemble cables and wires for an aircraft, this method was implemented by Tom Caudell and David Mizell. At the same time, Louis Rosenberg developed the first Augmented Reality system, called Virtual Fixtures, followed by another prototype named KARMA, created by Steven Feiner, Blair MacIntyre and Doree Seligmann. In 1997, Robert Azuma writes the first article in Augmented Reality, describing the system as a technology that combines the real environment with a virtual one while being both interactive in real time. Bruce Thomas developed the first outdoor mobile AR game in 2000, established during the International Symposium on Wearable Computers. Later on, more and more AR applications are created, such as a camera system that can relate positions between objects and environment [2].

## **2. Methodology**

The technology of Augmented Reality consists of two main stages: tracking the object and reconstructing or recognizing it. The tracking step can be realized with different image processing methods. These methods can be feature-based or model-based. The feature-based method consists of connecting the 2D form of the object with the 3D coordinates, while the model-based method consists of recognizing 2D templates of the object based on detectable features and make the connection with the 3D coordinates. Now, the visual tracking systems rely on other systems such as GPS and accelerometers. A recent approach in visual tracking methods study the perception of the human brain over the objects, this method is called Human Vision System (HVS) [3].

For the highest impact use cases, Augmented Reality led to a series of benefits and requirements in the military training due to the diverse military operations. The main problem is keeping track of elemental information such as sites of friendly forces, buildings, addresses or identifiers, but with the ability of AR to augment one's view without obscuring the environment and to visualize urban structure in 3D it became a key benefit over the military maps [1].

In military training AR plays an important role. For example, a soldier can wear a system like the Land Warrior system containing a computer that can display a Situation Awareness (SA) information. This system can reduce infrastructure costs and the modeling and rendering requirements. Augmented Reality allows for more pragmatic interaction, creating multiple training situations and instead of using personnel resources as potential adversaries or having trainees learn against uninhabited spaces, a soldier could train against avatars [4].

Another possible use of the AR in training is searching for particular patterns for maintain awareness of potential threats [4].

For the best practices it's been developed several technologies. The first specific application is called "Super Cockpit" and was implemented for fighter pilots. It enables the pilot to operate the system at night [5]. Another system, called Battlefield Augmented Reality System (BARS), was initially built for operations, but it became useful for the training domain too, ensuring information about the infrastructure. Military operation in urban terrain (MOUT) requires the operation of trainees in urban structures with or against other live trainees which makes the technology of AR to become difficult. Only a few research prototypes optical see-through display are capable of occluding the real environment, by using a second display surface [6].

The disadvantages of Augmented Reality for training are the difficulty to implement the system and making the technology to meet some of the basic requirements in order to be a convenient system [1].

All in all, beside the applications described military training can also be catalogued as the ability to maintain and repair the military vehicles as a demanding element of mission requirements.

### **3. Results and discussion**

The field of Augmented Reality systems has a long list of applications specific to military training. It has been determined to have the potential to asset to these applications. However, the military requirements are more complex than simple civilian ones and they require more advanced technology that is narrowed by the hardware accessible to system designers and builders [1].

For the best results Battlefield Augmented Reality System (BARS) focused much effort on the user interface and human subjective assessments while trying to find a hardware that coincide with the demands of the training. The system mostly fails due to the lack of user acceptance rather than the technical reasons, but it is plausible to believe the system will find a place in the standard kits of military personnel [1].

AR provides some practical advantages in relation to virtual worlds. Incorporating virtual training systems into existing live-training facilities will reduce needs for modelling (and rendering) and other technological costs. The simulation of a specific virtual environment and the uncertain fidelity specifications of such a model makes this a costly necessity for interactive virtual environments. Virtual environments often require special navigation methods (e.g. joystick-based); AR eliminates this and allows the user to walk normally, the only disadvantage is that it requires a large tracking range. Given that AR may one day be an operational tool, the short-term goal is to use it for the military training as a real combat situation. AR allows for more realistic interaction among multiple trainees, since they see each other through their natural vision. Finally, instead of using personnel resources to take the roles of potential adversaries or having trainees learn against empty space, a soldier could train against avatars [1].

### **4. Conclusions**

In order for an Augmented Reality system to achieve appropriate techniques for intuitive cooperation between the user and the virtual environment is necessary to use an appropriate tracking device in the form of a wearable computer. This system is cost-affective, it can reduce the cost of the decorations needed to recreate the training environment and also can provide 3D images of the wires and cables of the military vehicles, training the military staff to solve the problems in a time-frame [1].

The purpose of AR is (generally) to superimpose digital information to the user's view of the physical world. The only problem might be when the user is overloaded with information. This requires that the super imposed digital information to be carefully selected so as not to impair the ability of the user to achieve or preserve its orientation in the physical environment. One consequence to this condition is that the information provided to each user needs to be relevant to the role of that user in depending on his specific role-in the team. For example, a commander will need to consider the global situation and how the various teams are supposed to work around a region, while a private on patrol may be concerned only with a very small area of the environment. Likewise, a medic will need health records and a path to a wounded soldier where, as a forward observer, recognizing information will take a few days to identify suspicious or unpredictable acts of the enemy. Ideally, an AR system (or any information delivery system) should be aware of these specific tasks, and the current roles that can be performed by any particular user at any given time [1].

## REFERENCES

- [1] Furht B, Handbook of Augmented Reality, 2011.
- [2] Carmigniani J, Furht B, Anisetti M, Augmented reality technologies, systems and applications, Springer Science, 2010.
- [3] Feng Zhou, Henry Been-Lirn Duh, Mark Billinghurst, Trends in Augmented Reality Tracking, Interaction and Display: A Review of Ten Years of ISMAR, 2008.
- [4] Bolstad CA, Endsley MR, Tools for supporting team sa and collaboration in army, 2002.
- [5] Furness LTA, The application of head-mounted displays to airborne reconnaissance and weapon delivery, 1969.
- [6] Livingston MA, Rosenblum LJ, Julier SJ, Brown D, Baillet Y, Swan II JE, Gabbard JL, Hix D, An augmented reality system for military operations in urban terrain, 2002.

# ROBOTIC APPLICATIONS IN MILITARY FIELD

Robert Gabriel BUTNĂRAȘU

“Nicolae Bălcescu” Land Forces Academy, Sibiu, Romania

robert.butnarusul@gmail.com

Scientific coordinator: Assoc.Prof.Eng. Silviu Mihai PETRIȘOR, PhD

**Abstract:** *The general objective of the article is to find an optimal solution designed to ensure communications in the most varied situations, at relatively low cost and good quality. Robotic applications can intervene and help the communication systems to be as independent of the human resource as possible, thus we can create lines and networks of automated communications and informatics, that imply reducing the human factor. By this fact, a protection is achieved against radiation, but mostly it reduces their physical work and the risk of human error. At the current level it is desired to be able to ensure information flows and in the mobile moment. Satellite, or PTP (point-to-point) radios are required to ensure a high, constant and stable transfer speed. These radio lines use directional antennas that need to be aligned. Starting from this premise, the present paper attempts to find a real solution for aligning the antennas through self-stabilizing platforms that can ensure the alignment of the directional antennas, both satellite and radio antennas.*

**Keywords:** robotic, antenna, sensors, self-stabilizing.

In the military institutions, the field of communications has grown a lot in the last period, so the requirements are increasing and the specialized personnel less and less. Thus it is desired at the current level to be able to provide communications support in any location, but more importantly, it is desired to ensure the information flows and when the point requiring information services is a mobile one. Thus, a high speed of data transfer on mobile platforms (cars, airplanes and sea and river vessels) must be ensured. The current networks on these mobile platforms provide low transfer speeds and many of them are not interconnected on national and international networks.

Satellite, or PTP (point-to-point) radio links are required to ensure a high, constant and stable transfer speed. These radio lines use directional antennas that need to be aligned. Starting from this premise, the present paper attempts to find a real solution for the alignment of the antennas through self-stabilized platforms that can ensure the alignment of the directional antennas, both satellite and the antennas in the radiators of the radio systems. For this to be achievable we need the use of gyroscopic sensors, which collect information on the exact position of the antenna on the axes  $Ox$ ,  $Oy$  and  $Oz$ , but also an accelerometer type sensor to record the movement and the tendency of movement of the system. With these recorded data, step-by-step motors can be programmed to maintain a certain direction to a fixed point or even a mobile one. Thus, they can interconnect in the national and international networks of high capacity and mobile means, ensuring a very high speed of data transfer. This is not possible for humans because the response time of the sensors to control the stabilization

motors is significantly higher than the human reaction speed, providing the precision needed for link stability.

This paper aims to identify the sensors that could achieve the general objective proposed. First of all, you need to find a gyroscopic sensor or a combination of sensors that can respond correctly and in a timely manner to the data it measures.

By gyroscopic sensor we mean an electronic device capable of measuring the direction of orientation of an object or more precisely its position against an established initial position. This sensor can measure how inclined an object is and in what direction. Unlike the acceleration sensors that measure the acceleration of the object, practically the variation of life compared to the initial state.

Gyroscopic sensors are used in the orientation of objects that require exact orientation and this cannot be done by a specialized person. The use of sensors, and robots in general, provides accuracy and precision that is unmatched by humans. Another major advantage is the reaction speed of the sensors which is significantly higher than the human reaction speed.

The position in space is given by the values of the three axes, the axis OX, the axis OY and the axis OZ with respect to a chosen reference point. Once calibrated these sensors must be able to detect the exact position of the object studied. If the object studied is moving towards the chosen reference system, the gyroscopic sensors are combined with accelerometers capable of measuring also the speed with which the object moves.

The functioning of the gyroscope is based on the conservation of the angular impulse; a body that rotates about its own axis tends to maintain this axis of rotation and will oppose a disruptive impulse with another, along an axis perpendicular to the axis of rotation and on the axis of the disruptive impulse.

The principle of an accelerometer is based on the piezoelectric effect. For understanding it, it is necessary to imagine a sphere inside a cube. Piezoelectric crystals are the structure of the cube walls. Whenever the cube is tilted, the sphere is obligated to roll in the direction of the inclination due to gravity. Tiny piezoelectric currents are created after the collision with the walls. Each pair corresponds to a direction in 3D space: OX, OY, and OZ axes. It can be determined by the current produced from the piezoelectric walls, the direction of inclination and its magnitude.<sup>1</sup>

The paper is a type of empirical research and is based on gathering information from the environment and observing reality. It is based on a theoretical model, verifying the theory, and through the conclusions and the findings found can be found a real applicability. The sensors studied are HMC 5883L and GY-512 MPU-6050 which will be further detailed.

The HMC5883L is a reliable price-sensitive sensor that allows you to measure the magnetic field to report its position. We chose this sensor model because it allows us to observe the position of an object in relation to gravity. This sensor is a simplistic one that promises to provide accurate data on the position it determines. It is a sensor commonly found in digital compasses due to its simplicity and accurate and real-time data. Technical specifications:

- HMC5883L module (3-axis compass)
- Model: GY-271
- Power supply: 3-5V DC
- IIC communications protocol
- Measuring range: +/- 3-8 gauss

---

<sup>1</sup><https://www.elprocus.com/accelerometer-sensor-working-and-applications/>

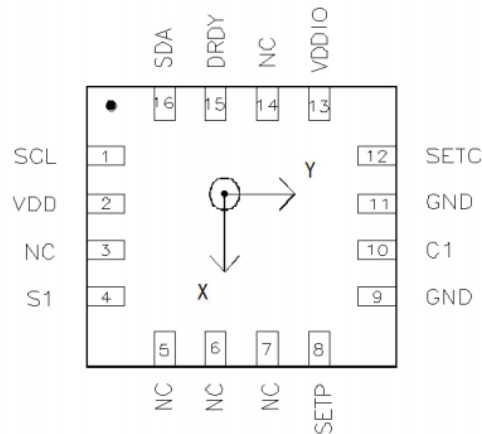

TOP VIEW (looking through)

Figure 1 – Technical scheme HMC 5883L<sup>2</sup>



Figure 2 – Image of HMC5883L

Gyroscope and Accelerometer module MPU-6050 with 6 axes, available for smartphone, tablet or other manual devices, including portable navigation devices. The MPU-6050 includes a MEMS accelerometer and a MEMS gyroscope, both in one chip. It's very accurate this includes 16 bit AD conversion for every channel. Thus, it captures the x, y and z channels simultaneously.

Along with the 6 axes it follows, this sensor also has a digital motion processor that allows the processing of received data. Thus the measured data are transformed into digitized information that can be used and processed by microprocessors or other specialized computer systems. This sensor is among the first of its kind in the world and comes in response to requests to create a sensor capable of measuring the position but also the acceleration of an object with a product that has small dimensions and a fair price.

Technical specifications:

- AD 16bit chip converter, data output
- Power supply: 3-5v (includes internal regulator)
- Communication: standard IIC protocol
- Gyroscope range:  $\pm 250$   $500$   $1000$   $2000$   $^{\circ} / s$
- Acceleration range:  $\pm 2$   $\pm 4$   $\pm 8$   $\pm 16g$
- Dimensions: 2 x 1.6 x 0.1 mm

<sup>2</sup>[https://cdn-shop.adafruit.com/datasheets/HMC5883L\\_3-Axis\\_Digital\\_Compass\\_IC.pdf](https://cdn-shop.adafruit.com/datasheets/HMC5883L_3-Axis_Digital_Compass_IC.pdf)



Applications:

- Movement based games
- Achieve augmented
- EEG imaging stabilizer (EIS)
- Optical Image Stabilizer (OIS)
- Controls applications through gestures
- Pedestrian navigation

The module contains an MPU-6050 integrated circuit with accelerometer, gyroscope and temperature sensor. It communicates on the I2C interface, needing only 2 connections. Each device that uses the I2C interface has its own address. The MPU6050 can select one of two available addresses, linking the ADO pin to GND or VCC. This connection is usually made on the module board.

It is useful in your projects that need to detect its movement and intensity, such as games, image stabilization, step counter.

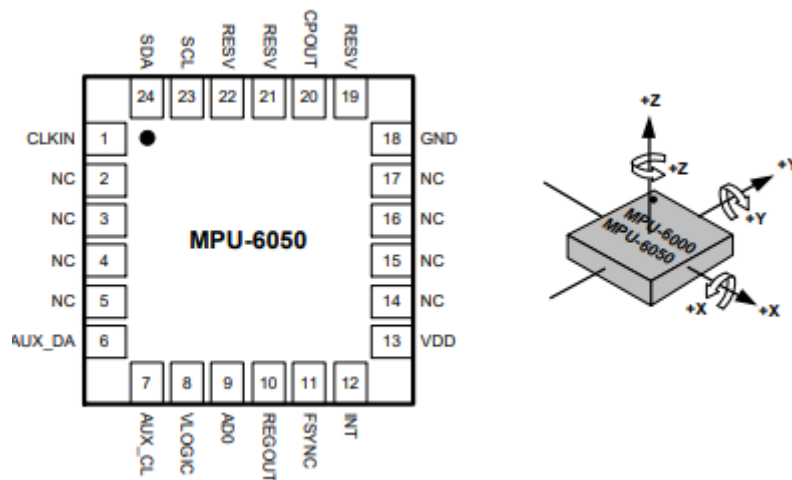

Figure 3 – Technical scheme of MPU-6050<sup>3</sup>

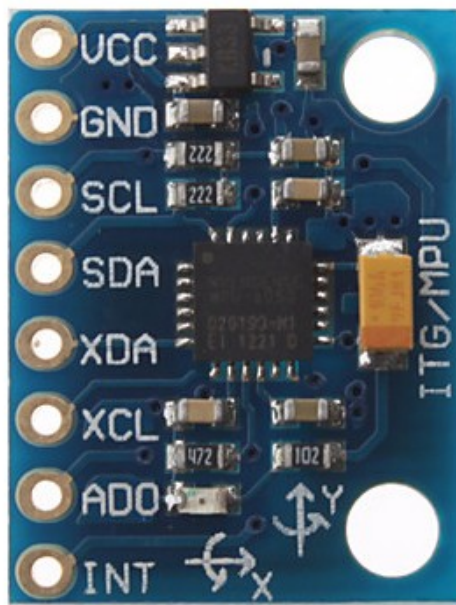

Figure 4 – Image of MPU-6050

<sup>3</sup><https://invensense.tdk.com/wp-content/uploads/2015/02/MPU-6000-Datasheet1.pdf>

Following the measurements made, by connecting these sensors to an ARDUINO UNO interface I noticed that the data received from these sensors are quite accurate compared to their price range. It could be a reliable solution for the purpose. Thus, the latter sensor measures practically 6 axes and it is better for our problem.

Arduino is an Open Source and Open Hardware project. Speaking of hardware, they are not revolutionary, they are basically a microcontroller + a voltage stabilizer + USB communication mode. Their popularity is mainly due to the large number of libraries used to connect different peripherals. These libraries are mostly written and published by people who subscribe to the "Open Source" philosophy.

Arduino UNO is an open-source development board built on the ATmega328P microcontroller. This one from the following shows an AVR processor with a RISC architecture (restricted instruction set).

Features of the microcontroller:

- 32kb program memory (non-volatile)
- Speed of 20 MIPS (20 million instructions per second)
- RAM (working) and ROM (non-volatile for storing information and after power off)
- communication with serial interfaces or with USB interfaces with other devices: UART, SPI, I2C
- Counters and comparators

The following diagrams were used to connect the modules to the ARDUINO type board:

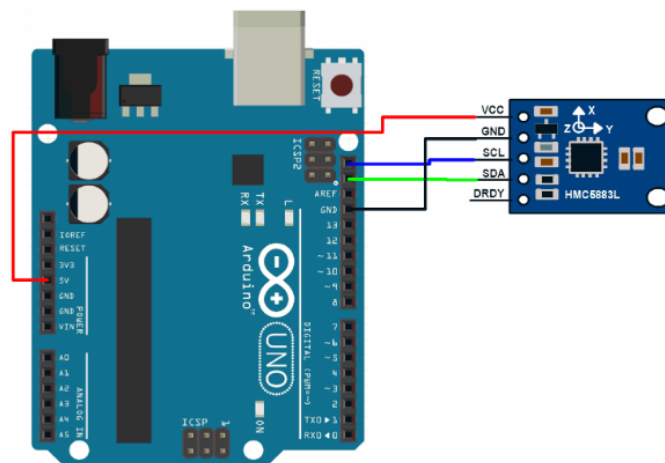

Figure 5 – Connections of HMC 5883L

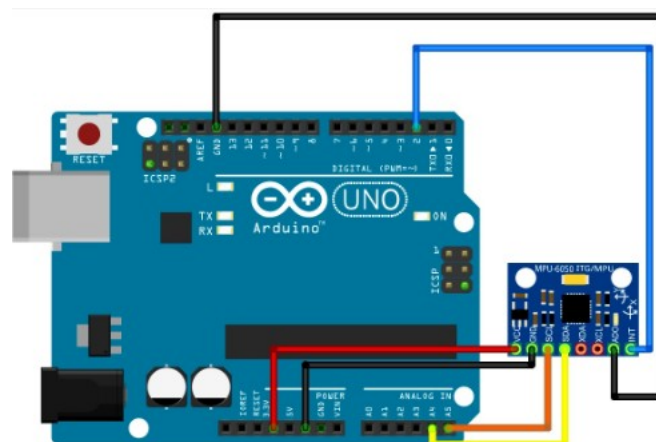

Figure 6 – Connections of MPU-6050

Sensor control by ARDUINO UNO hardware and software development boards is the most convenient method to achieve the proposed purpose. Thus, the data from the sensors can be accessed via the USB interface directly on the laptop or PC we are working on. After verifying that the program is running correctly and the data entered can fulfill our purpose, the sensor, together with the ARDUINO board, can work independently. Thus, through this solution adopted, we gain space especially important for aligning small antennas. The simplicity and reliability of these electronic systems gives us the possibility to use them in almost any environment. The small size gives us the possibility to adapt and incorporate them in most existing systems. Another major advantage is that together with the sensors, we can control other systems so that the sensor output data is input data for other devices (for example, for motors that automatically align an antenna or to maintain a system on a certain direction).

The implementation of the sensors ordered with the help of microcontroller-based systems can offer reliable solutions in the field of military communications. The applicability of these systems is very wide, the only limit being the imagination of the programmer. By implementing these robotic applications, human work is greatly diminished and the quality and precision are greatly improved. By integrating software applications into military communications systems, the chance of human error is greatly reduced and thus, systems become increasingly autonomous and more capable of resolving their own errors or failures that may occur.

#### **BIBLIOGRAPHY**

Rindler Wolfgang, Essential Relativity: Special, General, and Cosmological, New York:D. Van Nostrand Company, 2007

R. Takaeda, S. Tadano, A. Natorigawa, M. Todoh. Gait posture estimation by wearable acceleration and gyro sensors, Sapporo, 2009

Ian Chow Miller. Sensors and the Enviroment, New York: Cavendish Square, 2009

# SOLVING LINEAR PROGRAMMING PROBLEMS USING MANAGEMENT SCIENTIST

Bogdan Marius CÎMPULUNGEANU

“Nicolae Bălcescu” Land Forces Academy, Sibiu

cimpulungeanu.bogdan@yahoo.com

Scientific coordinator: Assist.Prof. Alina BABOȘ, PhD

**Abstract:** *Over time there have been difficulties due to the large number of variables and reaching a suitable solution. Lately, there is competition on the software side because any company wants to maximize profit, in accordance with minimizing costs. It is also looking for a model that will balance the perception of the most complex analysis model and the ease of distinguishing it. Representing the linear programming problem helps us in coordinating the resources we have available, as efficiently as possible to obtain a maximum profit. Such a problem does in fact mean calculating the maximum or minimum value of a linear function, where the optimization variables are destined to constraints.*

**Keywords:** linear programming problems, application

## About Management Scientist

The Management Scientist application is a program equipped with different numerical algorithms that helps us determine the optimal solutions within a complex decision problem. This program has 12 types of mathematical programming problems such as: linear programming problems, transport problems, decision analysis problems, inventory problems and so on.

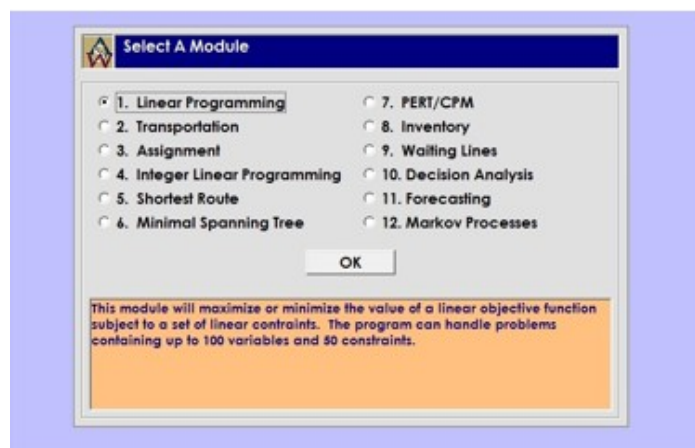

Fig. 1: The main menu in Management Scientist

The application is very useful for students who solve mathematical programming problems. The software is very easy to use even for users who have not worked with it since it has an easy-to-understand graphical interface. The application offers explanations and helpful menus while users are using the program. Through this software, the problems are solved by following the following steps:

- Establishing the problem;
- Calculation of the problem;
- Exposure of the results.

After opening the program the user must go through the following steps:

- Choosing the type of mathematical problem from the main menu of the application (Top Level Menu);
- From the Problem Selection Menu a new problem is created or a problem can be opened that we have previously worked on which we want to modify.
- The operations to be executed on a problem are performed from the Problem Disposition Menu;

Next I will present you a problem in order to obtain a maximum result of using the weapon systems solved with the application Management Scientist.

### Determine the optimal number of weapons to destroy the enemy

It is considered that to destroy the enemy's living force, two types of weapons are used: 7.62 mm machine gun and 7.62 mm machine gun. It is not known exactly the distance from which the enemy will act. Let's say that he will attack with 25 soldiers at short distances, with 50 soldiers at medium distances and with 75 soldiers at long distances. The two types of weapons can shoot at any distance, but the probability of destroying the target based on the distance is shown in table 3.1 It is required to calculate the number of weapons of each type so that the number of destroyed targets is not less than the number of attacking military, and the cost of the weapons used is minimal.

The type of weapons	The probability of hitting the enemy			The cost of a weapon
	small	average	big	
Submachine gun	0.8	0.4	0.3	50
Assault rifle	0.2	0.6	0.7	60
Number of attacking military units	50	75	100	-

Formulation of the mathematical model:

We note with  $x_1$  the number of machine guns, and with  $x_2$  the number of machine guns. The objective function will be of the form:

$$\min z = 50x_1 + 60x_2$$

#### Constraints

- The number of targets destroyed should not be less than the number of attacking military:

$$0.8x_1 + 0.2x_2 \geq 50$$

$$0.4x_1 + 0.6x_2 \geq 75$$

$$0.3x_1 + 0.7x_2 \geq 100$$

- Required, the number of weapons of each type must be greater than 0:

$$x_1 \geq 0 \text{ \& \ } x_2 \geq 0$$

We will solve this problem with the help of the Management Scientist application. We will open the application and choose the File menu and then press the New button to create a linear programming problem. Further, in the new window shown in figure 2 we will enter the

number of decision variables, no constraints and the type of optimization of the problem, in our minimization case, after which we will press the OK button which will generate a new window in which the coefficients will be written the functions that give the constraints, the coefficients of the objective function, the relational operators and the values in the right member of the constraints.

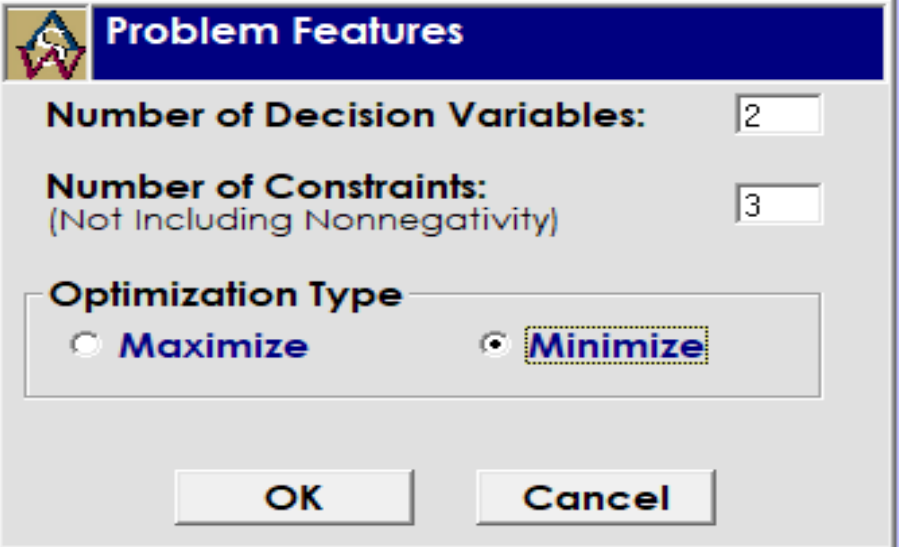

Fig. 2: Setting the number of variables and constraints.

Optimization Type: Min				
Objective Function				
Variable Names:	X1	X2		
Coefficients:	50	60		
Constraints				
Subject To:	X1	X2	Relation(<.=.)	Right-Hand-Side
Constraint 1	0.8	0.2	>	50
Constraint 2	0.4	0.6	>	75
Constraint 3	0.3	0.7	>	100

Fig. 3: Entering the problem data

After you have finished entering all the problem data, select the Solution menu and press the Solve button that will generate the problem result shown in figure 3.

Optimal Solution			
Objective Function Value = 9300.000			
Variable	Value	Reduced Costs	
X1	30.000	0.000	
X2	130.000	0.000	
Constraint	Slack/Surplus	Dual Prices	
1	0.000	-34.000	
2	15.000	0.000	
3	0.000	-76.000	
OBJECTIVE COEFFICIENT RANGES			
Variable	Lower Limit	Current Value	Upper Limit
X1	25.714	50.000	240.000
X2	12.500	60.000	116.667
RIGHT HAND SIDE RANGES			
Constraint	Lower Limit	Current Value	Upper Limit
1	28.571	50.000	266.667
2	No Lower Limit	75.000	90.000
3	81.250	100.000	175.000

Fig. 4: The result of the problem.

From the last figure, we can see that the number of machine guns is 30, and that of the machine guns is 130, and the minimum cost is 9300.

### Conclusions

To make a decision, the commander must take into account the influence of the qualitative and quantitative factors that define and influence the execution of certain actions or activities. The purpose of this paper is to solve the problems regarding the organization and planning of actions through applications that offer us the optimal variant for the specific situation.

### BIBLIOGRAPHY

- Căruțașu, Vasile, Alina Baboș, *Culegere de probleme de cercetări operaționale*, Editura Academiei Forțelor Terestre “Nicolae Bălcescu”, Sibiu, 2016.
- Căruțașu, Vasile, *Cercetări operaționale și teoria deciziei*, Editura Academiei Forțelor Terestre “Nicolae Bălcescu”, Sibiu, 2014.
- Cerchez Mihai, *Probleme pentru aplicarea matematicii în practică*, Editura Didactică și Pedagogică, București, 1982.
- Cocan, Moise, Anca Vasilescu, *Programare matematică folosind MS Excel Solver, Management Scientist, Matlab*, Editura Albastră, 2001.
- Ion D. Ion, Corneliu Zidăroiu, Nicolae Popoviciu, *Elemente de algebra și programare liniară*, Editura Didactică și Pedagogică, 1972.
- Kovacs, Adalbert, Gheorghe Țigan, Laura Kovacs, Constantin Milici, *Matematici superioare asistate de calculator*, Editura Politehnică, Timișoara, 2006.
- Purcaru, Ion, *Matematici generale și elemente de optimizare*, Editura Economică, București, 2004.
- Zidăroiu, Corneliu, *Programare liniară*, Editura Tehnică, 1983.

# A STUDY ON THE DISTRIBUTION OF NON-IONIZING RADIATION IN THE HUMAN BODY

Ovidiu CIRIMPEI

“Nicolae Bălcescu” Land Forces Academy, Sibiu  
cirimpei.ovidiu@gmail.com

Scientific coordinator: Prof.Eng. Simona MICLAUȘ, PhD

**Abstract:** *The purpose of this study is to analyze the distribution of non-ionizing electromagnetic radiation in the human body. To achieve this scientific objective, specially designed equipment will be used to measure radiation on models that faithfully reproduce the dielectric properties of the human body. In particular, the focus has been on the measurement of radiation found in a specific environment for professional activity. Scenarios were created in which different types of human tissues were exposed to various sources of non-ionizing radiation. The experiments were carried out on different types of models and different radiation sources were used. The purpose of the experiments is to raise awareness of the amount of radiation that the human body receives in the course of professional activities.*

**Keywords:** specific absorption rate, dielectric properties, human body, radiation, non-ionizing.

## **Presentation of the devices used**

As the electromagnetic field is determined and the amount of energy absorbed, in the last period, the need for biological materials as complex as possible has been obtained in order to obtain the most realistic distribution results inside the body. Thus, different recipes have been designed with different liquids that simulate the permittivity and conductivity of biological tissues. Usually, these liquids must have several characteristics, including: allowing the movement of the probes, being homogeneous, non-toxic and easy to obtain, their volume and density being known [1].

The dielectric parameters of the tissues depend directly on the frequency and temperature, so at different frequencies each substance has certain characteristics and is present in different percentages.

The following materials were used to carry out the experiment:

- Human body model
- Frequency generator
- Horn antenna
- Spectral analyzer
- Probe for measuring the electric field level

The set created for conducting the experiment is shown in the following figure (Figure 1):





Figure 1. The laboratory created for the experiment

The experiment was based on the frequency generation in the 2.6-5 GHz spectrum with the 200 MHz step through the frequency generator. The radiation was directed through the horn antenna towards the manikin that simulates the head of the human body. Inside the dummy a probe was introduced which together with the spectral analyzer had the role of measuring the distributed energy level [2].

The measurements were performed in three situations. In the first case, the manikin had no liquid inside, in the second it was filled with 5 liters of water at a temperature of 20 degrees Celsius, and in the third case the manikin was filled with a mixture of water and fine salt dissolved. This mixture was created from the desire to simulate the dielectric properties of the human head as accurately as possible.

#### **Measurement of the electric field level**

The electric field was measured in all three hypostases, generating frequencies from the aforementioned spectrum. (2.6-5 GHz)

For the first situation, the following variation of the electric field was obtained according to frequency. (Figure 2)

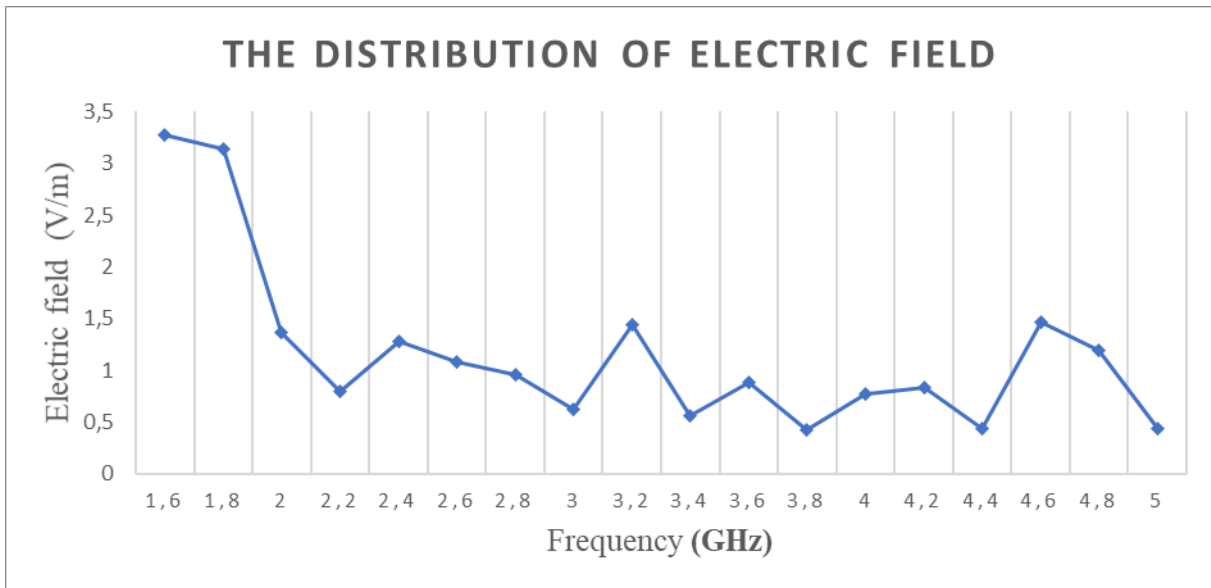

Figure 2 The distribution of electric field

It can be observed that as the working frequency increases, the value of the electric field decreases. In (Figure 3) is represented the variation of the power difference in frequency band.

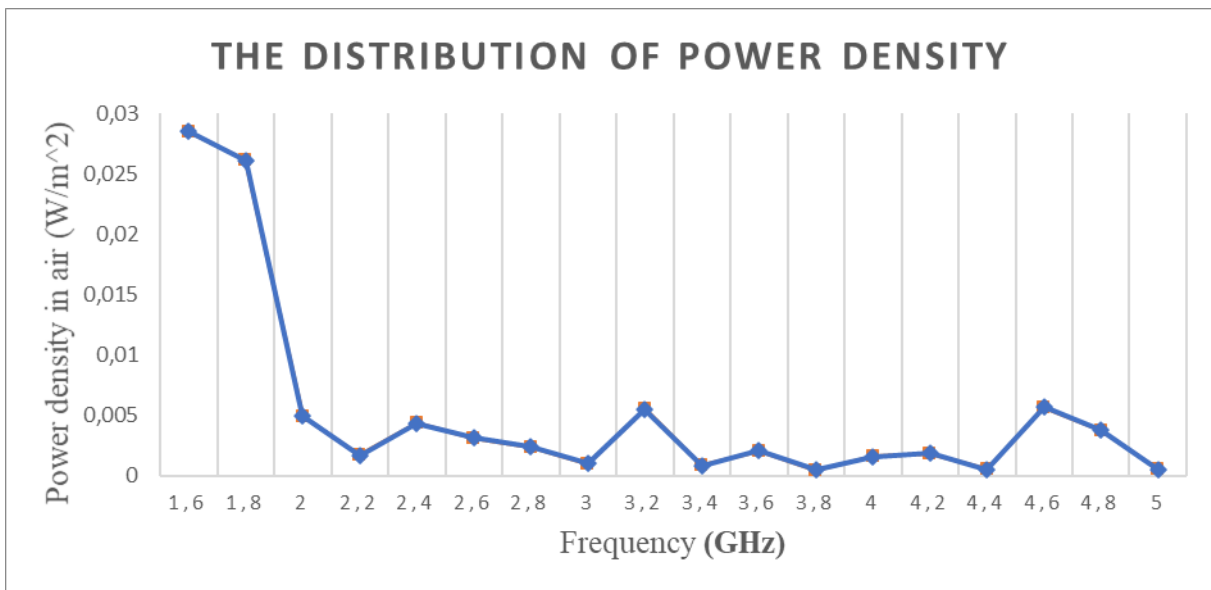

Figure 3 The distribution of power density

As in the case of the electric field, and in the case of the distribution of the power density, its value decreases with the increase of the working frequency.

In (Figure 4) is represented the variation of the electric field as a function of frequency in the case of the water filled dummy. In (Figure 5) is the variation of the electric field in the case of the dummy filled with the mixture of water and salt which is intended to reproduce the dielectric properties of the water. of the human body.

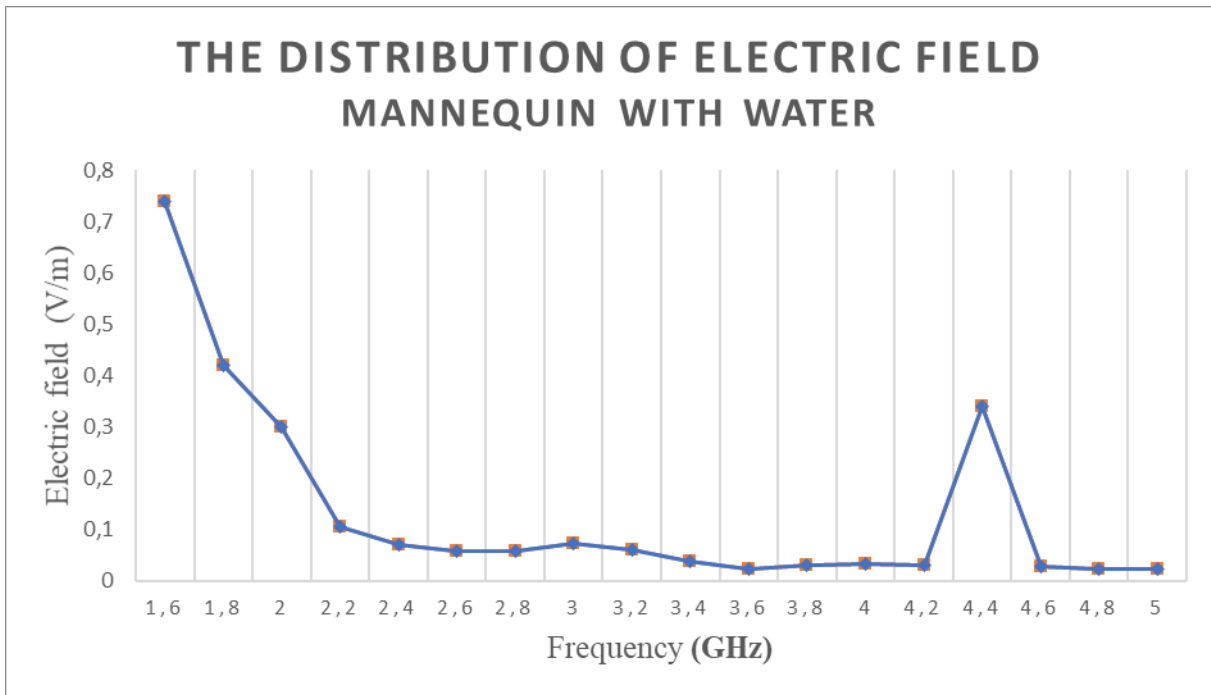

Figure 4 The distribution of electric field in the mannequin with water

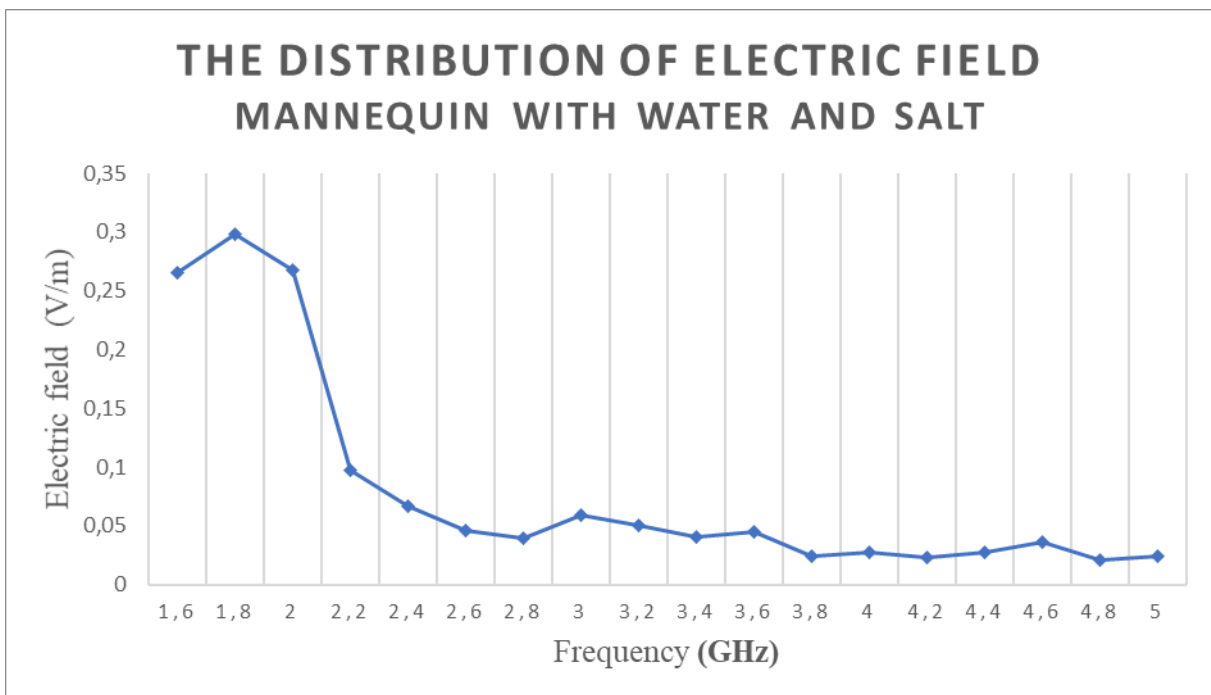

Figure 5: The distribution of electric field in the mannequin with water and salt

In (Figure 6) is represented the variation of the electric fields according to frequency in all the three situations discussed above.

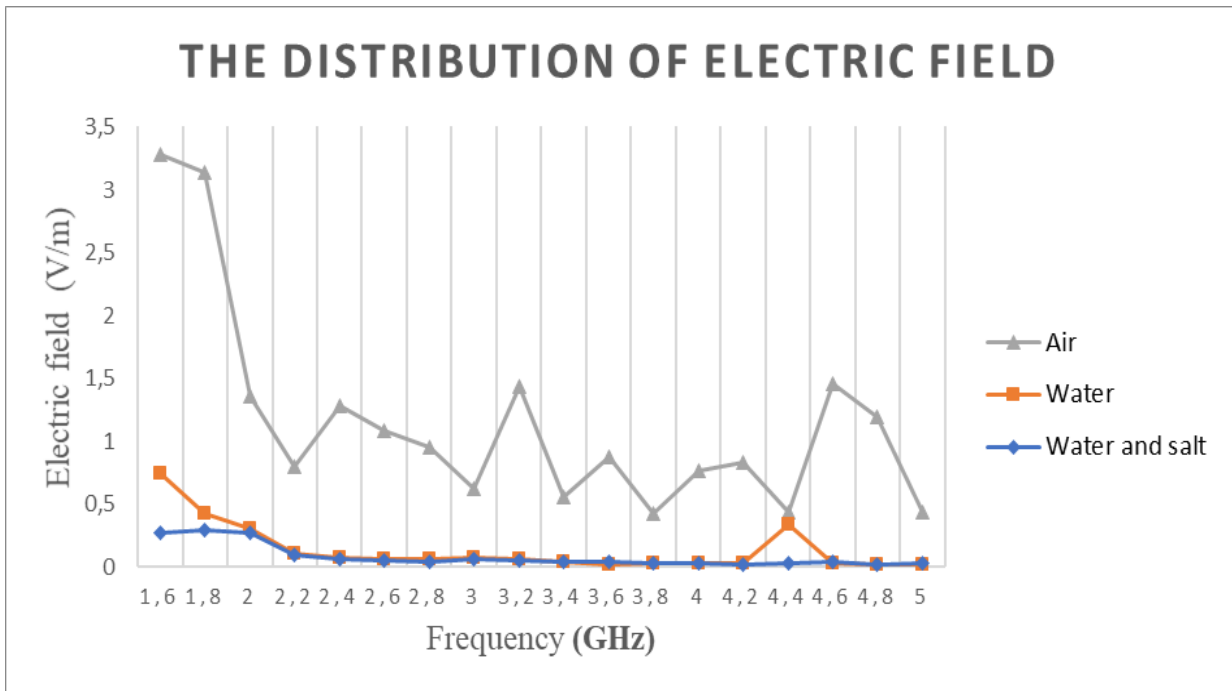

Figure 6: The distribution of electric field in all situations

As can be seen in (Figure 6), the closer the dummy is to the actual dielectric properties, the lower the level of distributed electric field decreases.

The following figure shows the variation of the specific absorption rate as a function of frequency.

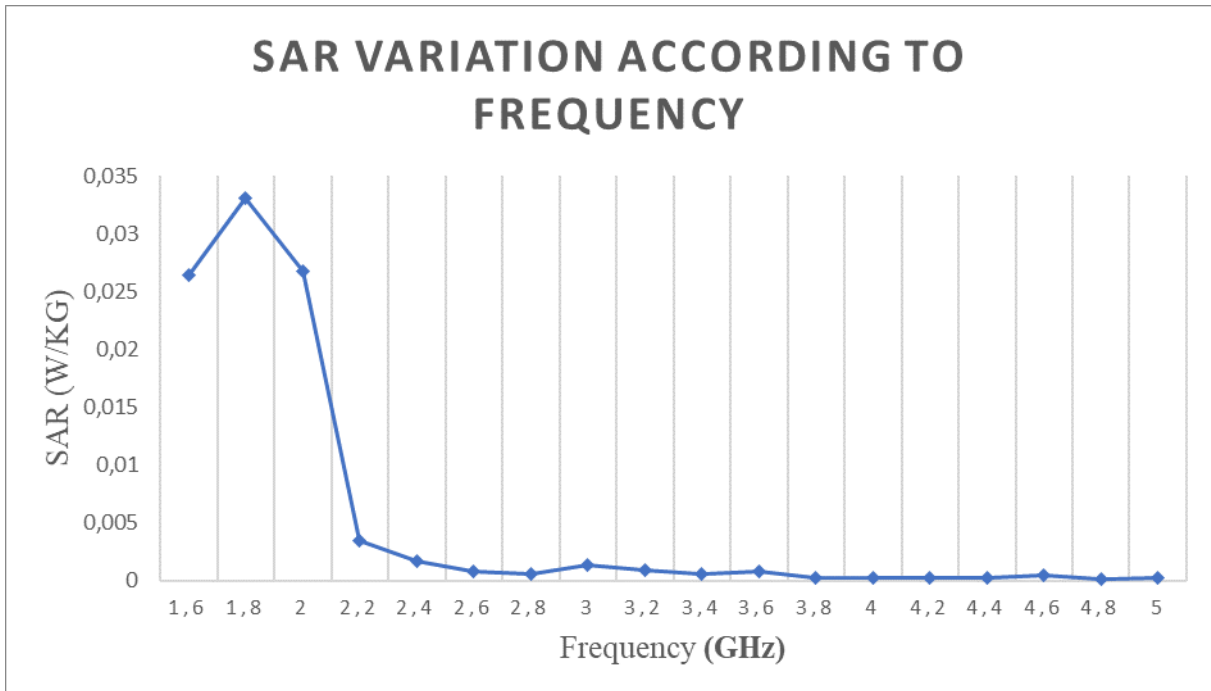

Figure 7: SAR variation according to frequency

As can be seen in the figure, the specific absorption rate decreases with the increase of the working frequency, when all measurements were made with the dummy located at the same distance from the radiation source, the horn antenna.

## Conclusions

The last few years have undergone an unprecedented series of technological developments that change our day-to-day way of life, especially health. With the emergence of various sources of radio frequency as well as their improvement in terms of emission mode, an important aspect has been recorded among humans, namely the effect that various electromagnetic radiation behaviors have on human health. The greatest danger is the prolonged exposure to such radio frequency sources, because although the effects are not felt at the moment they are much more destructive because they manifest themselves over time [3].

Based on the aspects presented above I have laid the foundations for the construction of the present work, in order to briefly study the effects of radiation on the human body. The analysis and forecasting activities of electromagnetic waves, such as: testing and planning of radio frequency sources, determining susceptibility limits, determining radiation levels, are considered as significant and useful [4].

## REFERENCES

- [1] Kwan-Hong, *Non-Ionizing Radiations-Sources, Biological Effects, Emissions and Exposures*, Malaysia, University of Malaya, 2003, p.3-5
- [2] Miclăuș Simona, *Introducere în bioelectromagnetica microundelor*, Sibiu, Universitatea "Lucian Blaga", 1999, p 16-18
- [3] Cynthia Furse, Douglas A. Christensen, Carl H. Durney, *Basic introduction in bioelectromagnetics second edition*, USA, CRC Press, 2009, p. 195
- [4] Carl H. Durney, Habib Massoudi Magdy F. Iskander, *Radiofrequency radiation dosimetry handbook fourth edition*, Brooks Ai Force Base, 1986, p 61-62

# APPLICATIONS FOR NUMERICAL METHODS OF DIFFERENTIAL EQUATIONS IN THE MATLAB PROGRAM

George Cătălin CLINCESCU  
“Nicolae Bălcescu” Land Forces Academy, Sibiu  
vldvoro@gmail.com  
Scientific coordinator: Assist.Prof. Alina BABOȘ, PhD

**Abstract:** *In this paper called Applications for numerical methods of differential equations in the MatLab program, in the first part we will present, in short, what is the notion of differential equation. In the second part, they will be presented types of numerical methods, namely the Euler method, the Runge-Kutta method, the Adams Bashforth method and some derivatives of them, and in the last part of this paper, they will be realized, applications that implement these numerical methods through the specific codes and interface of the MatLab program, where they will be calculated, and, subsequently, they will be displayed graphs obtained for each method separately.*

**Keywords:** differential equation, numerical method, MatLab program, codes, graphs

## 1. DIFFERENTIAL EQUATION

In the first part of this paper we will make a short introduction of the notion of differential equation.

Definition 1: The differential equation is called an equation which contains an independent variable  $x$ , a function  $y$  of this variable and the derivatives of  $y$  up to a certain order, being of the form:

$$F(x, y, y', y'', \dots, y^{(n)}) = 0 \quad (1)$$

The largest order of derivation is called the order of the differential equation.

Definition 2: It is called the solution of the differential equation, a function  $y = \varphi(x)$  such that replacing in  $F(x, y, y', y'', \dots, y^{(n)}) = 0$  on  $y$  with  $\varphi(x)$ ,  $y'$  with  $\varphi'(x)$  and so on, equality 1 becomes an identity.

## 2. TYPES OF NUMERICAL METHODS

In the second part, they will be presented types of numerical methods.

a) The Euler type methods fall into the single-phase methods, having an explicit algorithm, because to determine the values of  $b_i$  only one last point is used, which corresponds to  $a_{i-1}$ . These methods are among the most difficult if we want to numerically approximate higher order derivatives because they need to evaluate these derivatives for functions  $b(a)$  and  $g(a, b)$ .

b) Runge-Kutta methods have a high order, are non-linear and retain the main characteristics of single-step methods. These methods have the following main properties:

- it is necessary to have from the points  $a_i$  and  $b_i$  the information already known to find the approximate solution at step  $i + 1$ , this being a direct method
- until the terms of the form  $h^n$ , where we have  $\mathbf{h}$  as the current step and  $\mathbf{n}$  is always different for each method by defining the order of the method, are the same as the Taylor series
- In performing the calculation, it is only necessary to estimate some values  $\mathbf{a}$  and  $\mathbf{b}$  from the right member of the equation. In addition, there is no need to calculate their derivatives.

c) In the case of the Adams-Bashforth method, also known as explicit Adams, we will replace the function  $g(u, a(u))$  with a Newton polynomial in the nodes  $u_i, u_{i-1}, \dots, u_{i-l+1}$ , where  $l$  is the number of nodes having degree  $l - 1$ .

### 3. APPLICATIONS IN MATLAB PROGRAM

Through this application will be implemented the three methods of differential equations above and a few derivatives of them, through the specific codes, which will be introduced from the keyboard and interface of the MatLab program. This application is easy to use.

In the first part of this application we will test the implementation of the Euler method and the other derivative methods.

a)  $\frac{dy}{dt} = \frac{t^2}{2y}$ , with initial condition  $y(0) = 1$

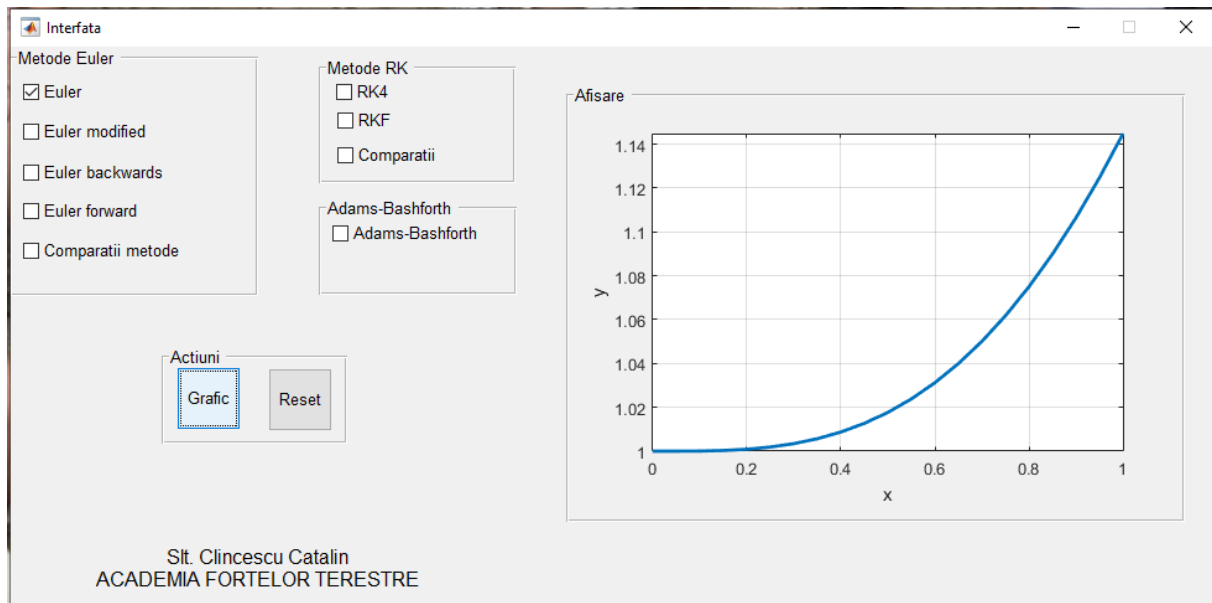

Figure 1 (Euler method)

It can be seen that the Euler method begins to increase from value 1 to value 1.15.

The following 3 graphs are derived from the Euler method, where the same equation is used.

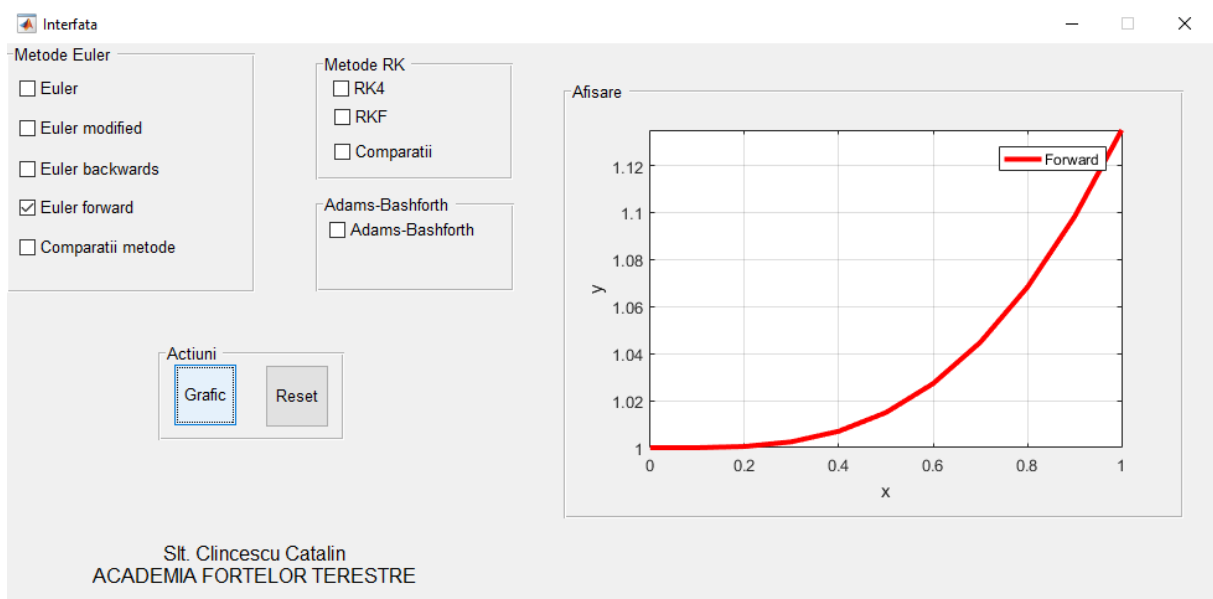

Figure 2 (Euler forward method)

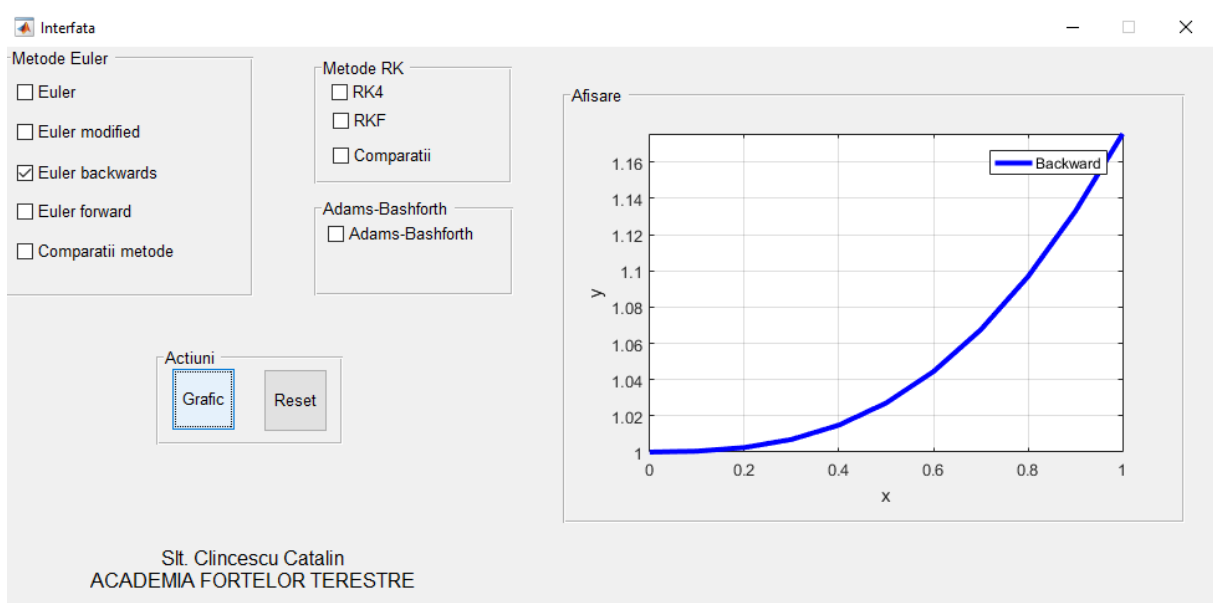

Figure 3 (Euler backwards method)



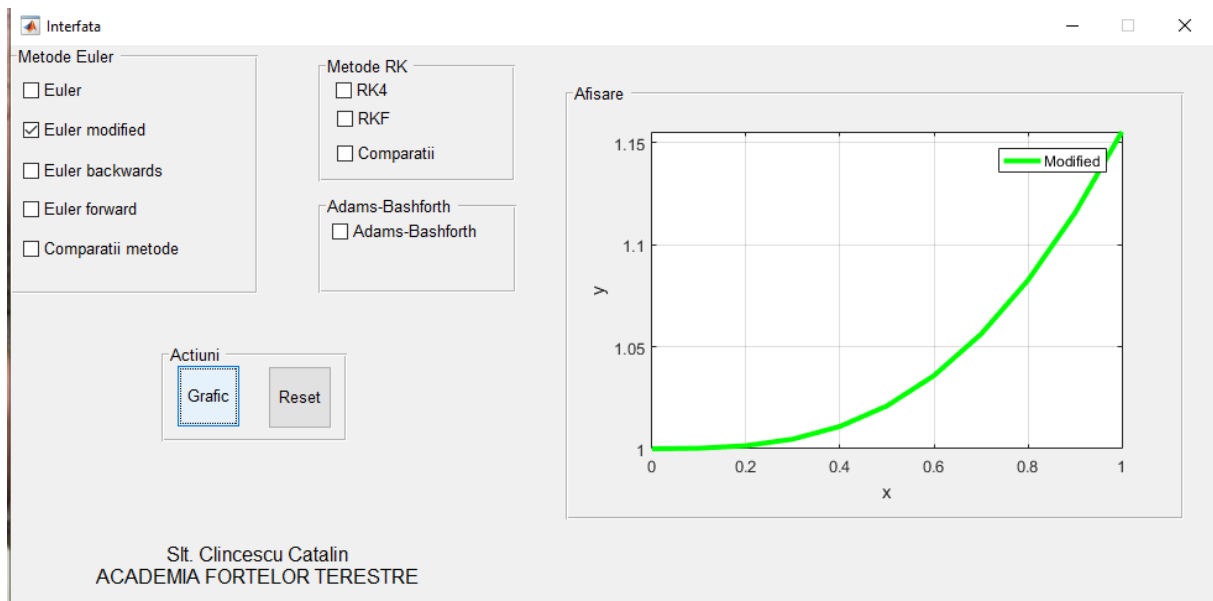

Figure 4 (Modified Euler method)

The following figure will show a comparison between the modified Euler method, Euler backwards and Euler forward.

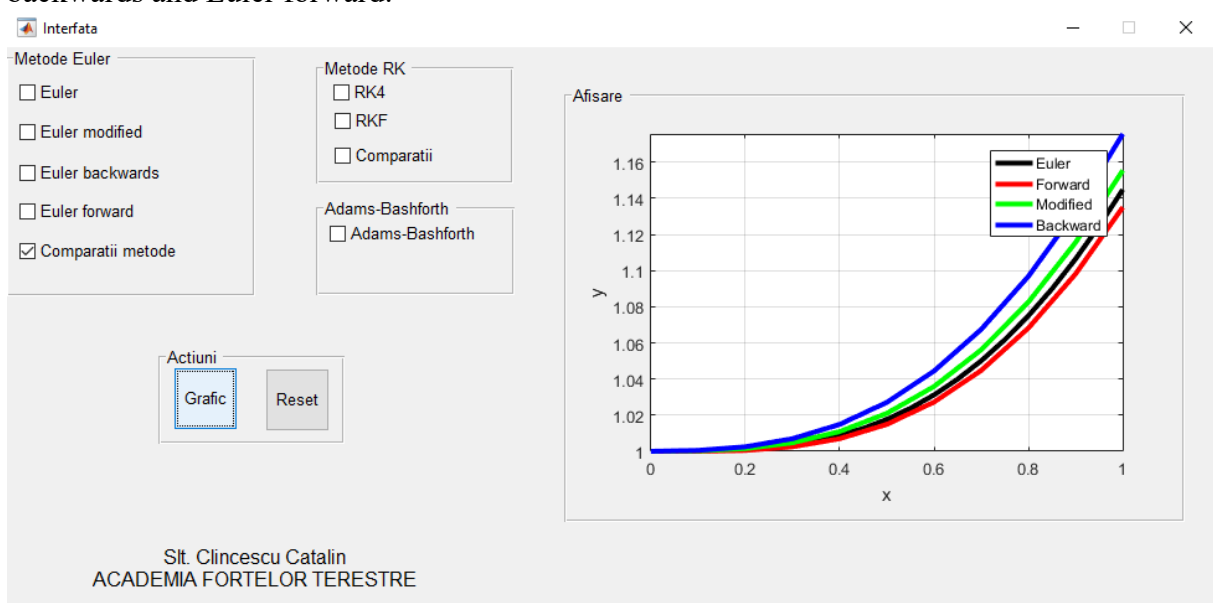

Figure 5 (Comparisons of the Euler methods)

From these graphs it can be observed that all the methods start from value 1 and gradually increase. In addition, it is noted that the Euler backwards method grows fastest to 1.18, the Euler forward method grows the hardest to 1.13, and the modified Euler method grows to 1.16 compared to the Euler method.

The second part of the application will test the implementation of the Runge-Kutta method and the Runge-Kutta-Fehlberg derivative method.

$$b) \frac{dy}{dt} = \frac{1}{2} e^{-\frac{t}{2}} - \frac{y}{2}, \text{ with initial condition } y(1) = 1$$

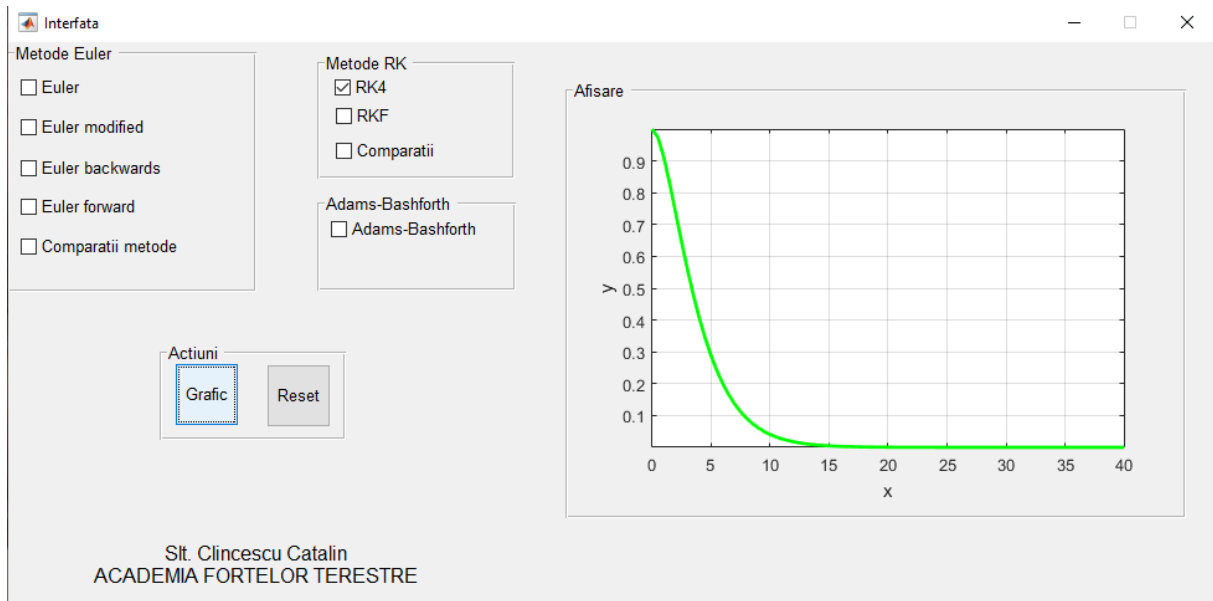

Figure 6 (RungeKutta method)

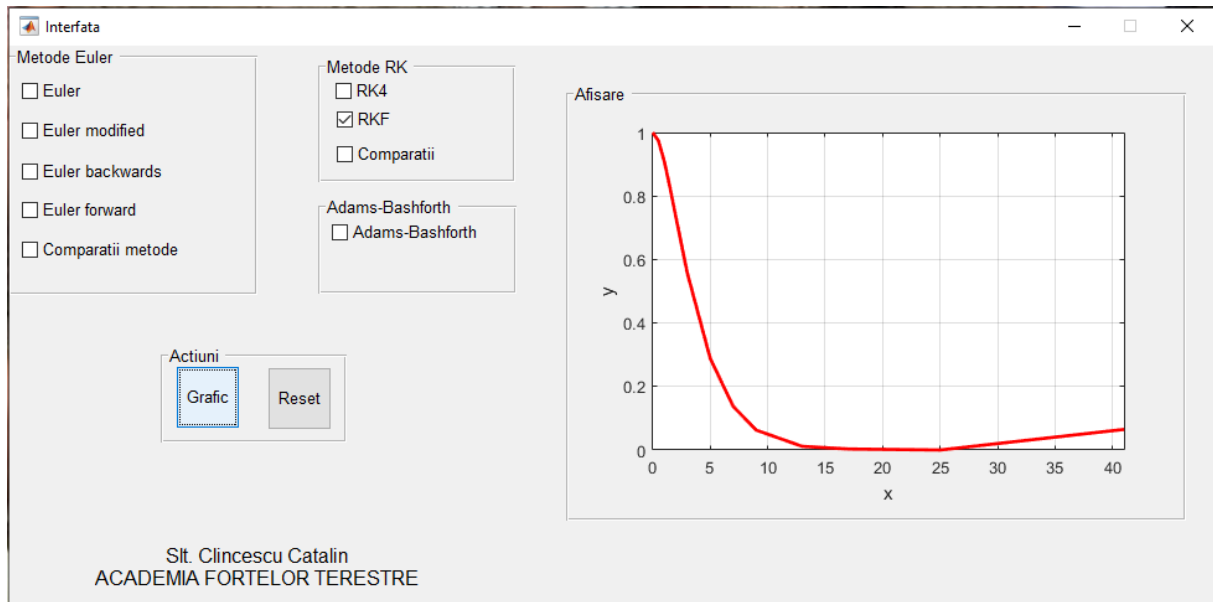

Figure 7 (RungeKutta Fehlberg method)

The following graph will show the comparison between the two methods.

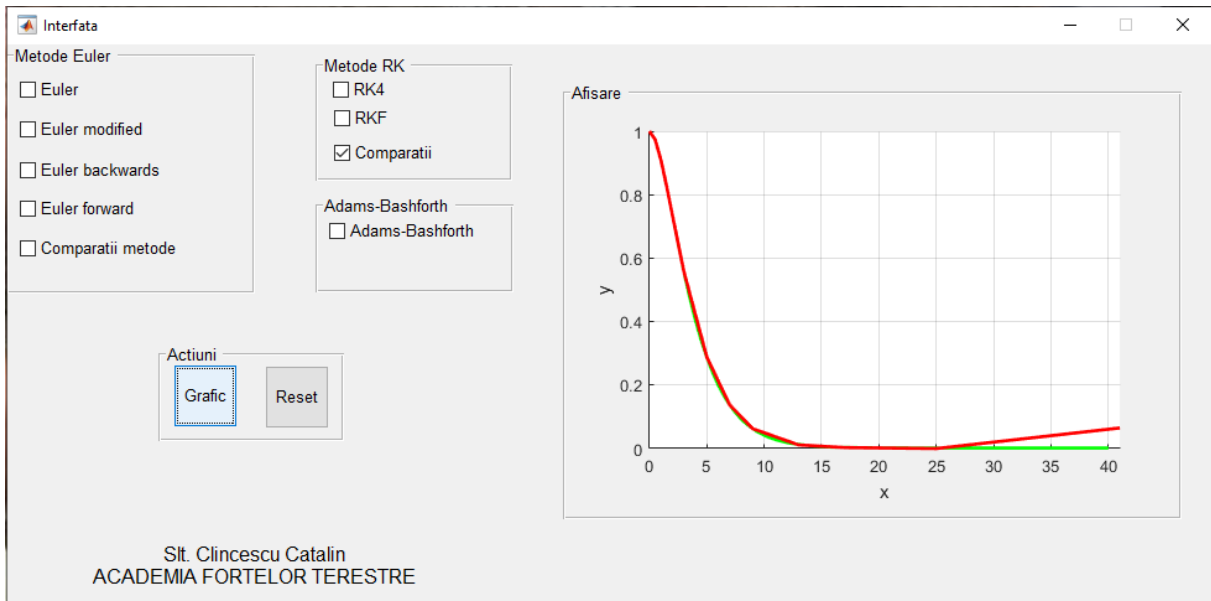

Figure 8 (Comparisons of Runge-Kutta methods)

The comparison shows that the methods are almost the same, the only difference is that, the Runge-Kutta method decreases to the coordinate point [40, 0], and the Runge-Kutta Fehlberg method decreases to the coordinate point [25, 0], and then it starts to grow.

The last part of the application will show the implementation of the Adams-Bashforth method.

$$c) \frac{dy}{dt} = t \cos \frac{t}{2} - \frac{1}{2} t^{-1} y, \text{ with initial condition } y(1) = 2.$$

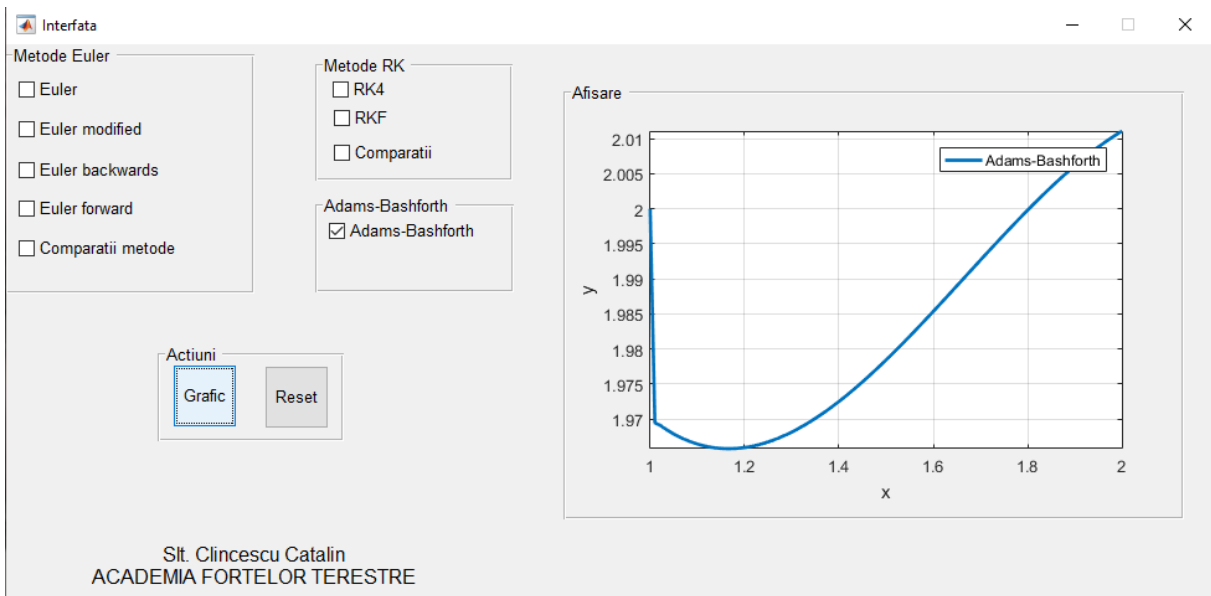

Figure 9 (Adams Bashforth method)

We can see in Figure 9 that the graph starts from value 2, drops sharply to value 1.97, then gradually decreases to value 1.2, and then follows a sharp increase to value 2.1.

#### **4.CONCLUSION**

In this paper we applied the mathematical knowledge, knowledge about the MatLab program and its codesthat we have acquired and learned over time, to integrate them in an interactive application, pleasing to the user's eye, with great utility in the study of solving numerical methods of differential equations of the Euler type, Runge-Kutta, Adams-Bashforth and certain derivatives of them.

#### **REFERENCES**

- [1] <http://maths.cnam.fr/IMG/pdf/RungeKuttaFehlbergProof.pdf>
- [2] <https://profs.info.uaic.ro/~fliacob/An2/2007-2008/Resurse%20de%20curs/Pentru%20ecuatii%20diferentiale%20si%20sisteme%20dinamice/Metode%20numerice%20pentru%20ecuatii%20diferentiale.pdf>
- [3] <https://profs.info.uaic.ro/~fliacob/An2/2012-2013/Resurse/Relative%20la%20Matlab/Tratarea%20EDO%20in%20Matlab.pdf>

#### **BIBLIOGRAPHY**

- Nicolau Elena, Didenco Teodora, Dochițoiu Ileana, Curs de matematici superioare pentru subingineri, vol. II, București, 1987
- Gavriil Păltineanu, Pavel Matei, Ecuatii diferențiale și ecuații cu derivate parțiale cu aplicații, București, 2007
- Dana Constantinescu, Ecuatii Diferențiale, Elemente teoretice și aplicații, Editura Universitaria, 2010
- Muraru, C.V., MATLAB. Ghid de studiu, Bacău, Editura Edusoft, 2008
- Ghinea Marin, Firișteanu Virgiliu, MATLAB Calcul numeric. Grafică. Aplicații, București, Editura Teora, 2004

# STUDY REGARDING THE PARTICULARITIES OF THE ELECTRIC FIELD LEVEL IN VARIOUS APPLICATIONS WITH MOBILE DATA CONNECTION OF A MOBILE TERMINAL

Eduard COGIANU

“Nicolae Bălcescu” Land Forces Academy, Sibiu  
cogianueduard@gmail.com

Scientific coordinator: Assoc.Prof.Eng. Silviu Mihai PETRIȘOR, PhD

**Abstract:** *The present paper will aim to outline an overall idea of the electromagnetic field levels in the most used applications for mobile terminals, first connected to the 3G network, and then connected to the 4G network, in order to be able to observe the particularities of each mobile communication standard. The rapid development of mobile system technologies has intensified the public's concern about the possible adverse health effects of exposure to electromagnetic radiation. All mobile phones must comply with national legislation that are based on international safety guidelines. Therefore, the main objective of the measurements made is to determine the levels of electromagnetic field in the proximity of the terminal, when running different applications on it.*

**Keywords:** Phone, Communications, Tehnology.

## 1. Introduction

Currently, the world mobile communications technology and especially for mobile data, Universal Mobile Telecommunications System (UMTS) is a third-generation (3G) mobile cellular system that uses broadband access to provide broadband access. higher spectral efficiency and bandwidth for mobile network operators. However, with low data delivery costs and increased performance for both voice applications and data services, the fourth generation of mobile cellular system (4G / Long-Term Evolution-LTE) increases data capacity and rate through implementation of a different radio interface that uses orthogonal modulation of frequency division multiple access mode (OFDMA) for downlink and single carrier access for uplink connection. This rapid development of mobile system technologies has heightened public concern about the potential adverse health effects of exposure to electromagnetic radiation. All mobile phones must comply with national regulations that are based on international safety guidelines. These standards have established basic restrictions that include adequate safety factors to avoid the dangerous effects due to excessive temperature rise in tissues. However, there is still sufficient public concern and scientific interest regarding the possible health consequences. Real-life situations constantly differ from test conditions, as a mobile phone can run a wide range of application services and rarely emit maximum power.

## **2. 3rd generation of mobile communications**

Third generation cellular networks have been developed to provide high speed data and multimedia connectivity to subscribers. The International Telecommunication Union (ITU), within the IMT-2000 initiative, defined 3G systems as capable of supporting high-speed data intervals of 144 kbps to over 2 Mbps. Some technologies are capable of meeting the International Standard of Mobile Telecommunications (IMT), such as CDMA, UMTS and some variations of GSM, such as EDGE.

## **3. 4th generation of mobile communications**

4G is the fourth generation of wireless cellular standards. In 2008, ITU-R specified IMT-Advanced (International Mobile Telecommunications Advanced) requirements for 4G offer a wide range of new services, from HD Voice to HD Video and high-speed wireless data channels. The term 4G is generally used to include several types of broadband wireless communication systems, not just cell phone systems. One of the terms used to describe 4G is Mobile multimedia, anytime anywhere, support for global mobility, integrated wireless solution and personalized services. The features of 4G systems could be summed up in one word - Integration. 4G systems are designed for seamless integration of terminals, networks and applications to meet the growing demands of users. The continuous expansion of mobile and wireless communications networks demonstrates an exceptional growth in the field of mobile subscriber, access to wireless networks, mobile services and applications.

## **4. Objectives**

Some objectives will be pursued that will outline an overall idea of the electromagnetic field levels in the most used applications for mobile terminals connected first to the 3G network, and then connected to the 4G network in order to observe the particularities. to each standard of mobile communications. The main objective of the measurements carried out is to determine the levels of electromagnetic field in the proximity of the terminal, when running different applications on it. A second objective is to observe and compare the differences between 3G and 4G communication standards.

## **5. Equipment and measurements**

The following devices, software and accessories were used to perform the measurements of the electromagnetic field. First of all I needed the AaroniaSpectran V5 X real-time spectral analyzer which is very fast, powerful and compact. This real-time USB spectrum analyzer is designed to capture even the shortest signal transmissions. The analyzer scans 20 GHz in less than 20ms, which is why it is the fastest USB spectrum analyzer in the world.

"RTSA Suite Pro" from Aaronia is an extremely powerful and flexible software, with an intuitive and highly customizable interface. Node-based software allows the user to identify, capture, demodulate, and track any signal and offers a variety of display modes. An electric field probe was connected to the real-time spectral analyzer to capture and measure the values of the electromagnetic field emitted by the mobile terminal. The probe is connected to the analyzer with an SMB cable to the SMA, both present in the analyzer's accessories. graph of signal detection. Another very important element of measurement is the mobile terminal. In this case, it is an Apple mobile phone, model Iphone 8 Plus (MQ8L2RM / A) connected to the services of the operator Vodafone Romania. The measurements were performed both within the 3G mobile communications standard and within the 4G standard:

- In 3G the connection took place on 3 frequencies, namely: 1,967 GHz, 1,972 GHz, 1,977 GHz. Depending on the degree of occupancy of these frequencies, the connection of the

mobile terminal was made on the freest frequency band in order to provide the mobile data user with quality resources.

- In 4G, due to the advanced technology and the bandwidth greater than the one of the previous standard (3G), the measurements were made on a single frequency, 1.72 GHz. The measurements were made in the following applications commonly used by the majority of the population: Facebook, FaceTime (Video call), YouTube and Whatsapp, the latter being monitored in three modes of use (Download, Upload and Text transmission). The antenna of the mobile terminal is located approximately in the center (figure 3.6) and determines the position of the electromagnetic field probe.

In order to carry out the measurements, certain stages have been established that allow the recording of values as close as possible to the real ones. For this purpose, these aspects were followed (the framework and the mode of measurements can be seen in figure 3.8): □

Establishing the workspace (laboratory);

- Installing Aaronia RTSA-Suite PRO data management, control and data acquisition software on a laptop;
- Connecting via the USB port of the AaroniaSpectran V5 X real-time spectral analyzer to the laptop on which the software was installed;
- Connecting the PBS E1 electric field probe to the spectral analyzer with an SMB cable to the SMA;
- Establishing a fixed position of the mobile terminal throughout the measurements;
- Anchor the electric field probe on a tripod, also having a fixed position throughout the measurements, at a distance of 20 cm from the mobile terminal to simulate the electromagnetic effect felt by the user's head when using the above applications with the mobile phone mentioned;

Once all the equipment has been connected and positioned according to the established algorithm, the optimal way to retrieve the data will be sought. That is why a very important part of the measurements is the setting of the settings in order to capture specific data. The set time for each type of measurement was approximately 15 seconds (14.95 seconds).

After the settings were made, measurements were made under similar conditions for each application run on the mobile phone. In the first phase, the applications ran with a connection to the 3G network, later the connection was switched to the 4G network for the same applications. To record the values, we proceeded as follows:

Selecting the application and using it according to the characteristics of each one:

- Facebook- this application was followed by the newsfeed, which displays photos, videos or advertisements;
- FaceTime- during the data capture using this application a video call was made;
- YouTube- in this case this platform has been running a video with maximum clarity;
- Whatsapp - this application has been tracked in three different functions because it is one of the most used applications in the world. In the first phase text messages were sent, then the second recording was sent a video file (upload), and finally a video file (download) was received.

## 6. Data processing and results

In order to be able to interpret the data recorded through the Aaronia RTSA-Suite PRO data acquisition, control and data acquisition software, they require prior processing. In the following, the data processing algorithm for the measurements made within the connection to a 3G network is presented.

- From the original file with 449 columns in the frequency domain, 190 columns representing the frequency band in which it has a width of 4.6 MHz were extracted;

- At the end of each column an average of the emitted power was made, during the 15 seconds, expressed in dBm;
- Further, the value of the average power expressed in dBm was converted to mW by the formula  $P = 10 \cdot \frac{P(dBm)}{10}$ ; s (1)
- After transforming the values into mW, these values were added and then the resulting value was divided by the number of selected columns, in this case 190;
- The value obtained previously was multiplied by the width of the frequency band used, over RBW (value displayed by the spectral analyzer software, 0.5 MHz);
- Finally, the previous results determined the power level in the channel using the formula

$$L_{ch} = 10 \log \cdot \frac{B_{ch} (Hz)}{RBW (Hz)} \cdot \frac{1}{n_2 - n_1} \cdot \sum_{n_1}^{n_2} \cdot 10 \frac{P_i}{10} (W); (2)$$

Following the application of this algorithm and the resulting values, two graphical representations of the power levels in the channel were constituted, comprising all 6 measurements of the applications used.

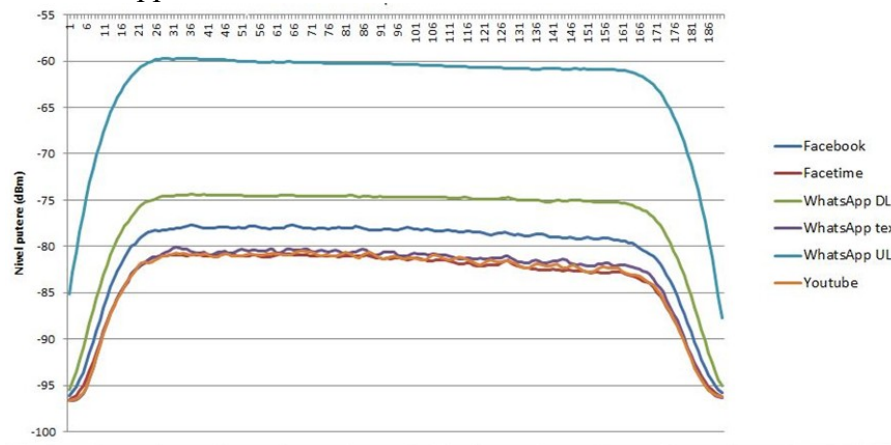

Figure 1

As can be seen in the figure 1 the highest level of power recorded is in the case of the Whatsapp application when uploading a video file. The power level in this case compared to the lowest level recorded is approximately 21 dBm, which means it is 126 times higher. Also, in cases where high values of the power level have been recorded, it is distinguished that this level remains approximately constant during the emission compared to the applications with a lower power level, where there are considerable differences between the frequency samples.

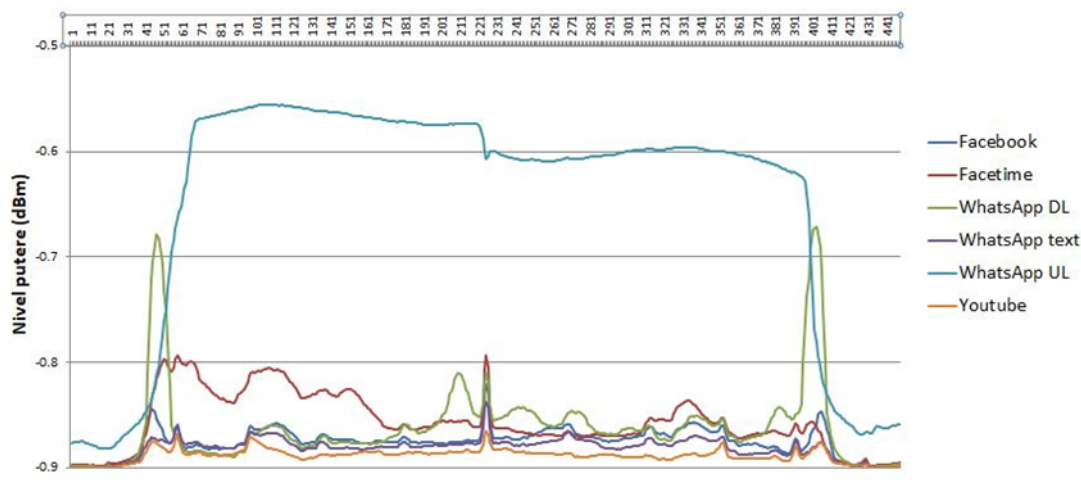

Figure 2



The results of the measurements in the case of connection to a 4G network show that the power level increased in all applications by about 7 dBm, that is, they increased 5 times compared to the previous case of the connection to a 3G network. Also, within the same network there is a very big difference between the smallest and the highest value registered, which is also Whatsapp at the time of upload. There is a difference of about 29 dBm which indicates a level almost 800 times higher.

## 7. Conclusions

In the first part of this paper the main communication standards used by mobile phones are presented and explained. The content of the measurements presented in this paper can contribute to the improvement of the approach regarding the assessment of the level of human exposure due to the radio emission technologies in the daily life of people. Currently, the near-radiated power of a mobile terminal has been measured for various communication services commonly used in 3G and 4G using an electric field probe connected to a USB real-time spectral analyzer. The aims of the paper were to evaluate the exposure of users to electromagnetic radiation felt by the human body, to observe the spectral features in the case of the two networks and the differences between them. Exposure situations in the medium and worst cases are discussed based on the data collected. The highest power levels for data uploading applications on 3G and 4G networks were encountered. The highest value recorded in both cases was in the Whatsapp application at the time of upload. The highest exposure of 4G measurements was also observed in the case of the Whatsapp application at the time of upload. The minimum exposure in both cases was measured for the Whatsapp application in the transmission of text messages, but not with a big difference from the FaceTime and YouTube applications. It has been shown that different generations of communication technologies lead to different exposure situations and that such information could be important and practical for mobile phone users, to be aware and to act to reduce electromagnetic exposure levels. Furthermore, power measurements allow the calculation of the radiated energy, which, if absorbed by the tissues, leads to their heating with possible biological or health effects. The measuring system is versatile, with the appropriate settings, it captures even the fastest changes of signal levels and frequencies.

## BIBLIOGRAPHY

Dahlman, E., S. Parkvall, J. Skold, and P. Beming, 3G Evolution: HSPA and LTE for Mobile Broadband, 2nd Edition, Elsevier, Department in Oxford, UK, 2008.

Parkvall, S. and D. Astely, "The evolution of LTE towards IMT-advanced," Journal Of Communications, Vol. 4, No. 3, Apr. 2009.

Progri, I., Geolocation of RF Signals: Principles and Simulations, Springer, USA, 2011.

Anton A. Huurdeman, The Worldwide History of Telecommunications, John Wiley & Sons, 31 juli 2003

<https://www.etsi.org/technologies-clusters/technologies/mobile/edge>

<https://www.etsi.org/technologies-clusters/technologies/mobile/gprs>

<https://www.etsi.org/technologies-clusters/technologies/mobile/gsm>

<https://www.etsi.org/technologies-clusters/technologies/mobile/imt-2000>

<https://www.etsi.org/technologies->

# VULNERABILITIES DETECTION IN VIRTUAL ENVIRONMENT

Vasile-Claudiu DINU

“Nicolae Bălcescu” Land Forces Academy, Sibiu

dinuclaudiu196@gmail.com

Scientific coordinator: Assoc.Prof. Romana OANCEA, PhD

**Abstract:** *The paper focuses on exemplifying the tools used to scan hardware devices in order to identify vulnerabilities. Because, in the virtual environment, operating systems such as Windows 8, Windows 10 and Linux were deployed, and each system was scanned with Kali Linux tools. Well-know vulnerabilities were analyzed for detected applications and ports.*

**Keywords:** tools, vulnerabilities, virtual environment, operating systems.

## 1. Introduction

I am firmly convinced that it can be clearly stated that we have reached the level of technological development at which any process is managed through a computer that analyzes, monitors and regulates processes so that they can be performed at normal parameters.

Although the processes have come to be controlled through computers, this does not mean by far that the errors have disappeared completely, have diminished to some extent, but not all have been adjusted so that we can state at the moment. that there are processes on the planet that are in perfect shape.

The cause is very simple; although processes are handled through computers, computers in turn have been, are and will be programmed by us people, who unfortunately although we are perfectable, we will never reach perfection, which is why the computer systems that are the basis on which they operate computers are still faced with all kinds of errors, programming errors, which at any time someone malicious will try to use in their favor to create annoyances, malfunctions at the macro level.

These security breaches that a malicious individual can take advantage of by doing a system harm are called vulnerabilities. Most of the time those who are committed to managing the errors of a program or system are hackers, those people who deal with vulnerability analysis at the level of complex processes behind the networks that most often lead to network compromise by infiltrating a virus. through the breach thus found.

The purpose of this paper is precisely to describe how we can use certain tools of the operating systems we have on our personal computers to analyze, identify, manage and try to remedy any vulnerability, or even worse, any vulnerabilities.

## 2. Description of the procedure by which the vulnerability analysis will be performed within several known operating systems

In order to be able to enter the field of cyber - security, especially the one of pen-testing, we must focus on creating an own network, similar to a lab environment, where we introduce several machines / operating systems, on which to we perform the vulnerability assessment part. Thus we will have 3 virtual machines running Kali Linux operating systems, Windows 7 and Metasploitable respectively.

The main machine we will work on will be Kali, being a Linux distribution, specially designed with hacking utilities. Both Metasploitable and Windows 7 are operating systems with vulnerabilities, they will represent our targets.

Thus we will proceed to the presentation of the network that was created. The machines we work on are all physically connected to the public network of the PC we operate, so they are all on the same network.

This can be seen through the images below.

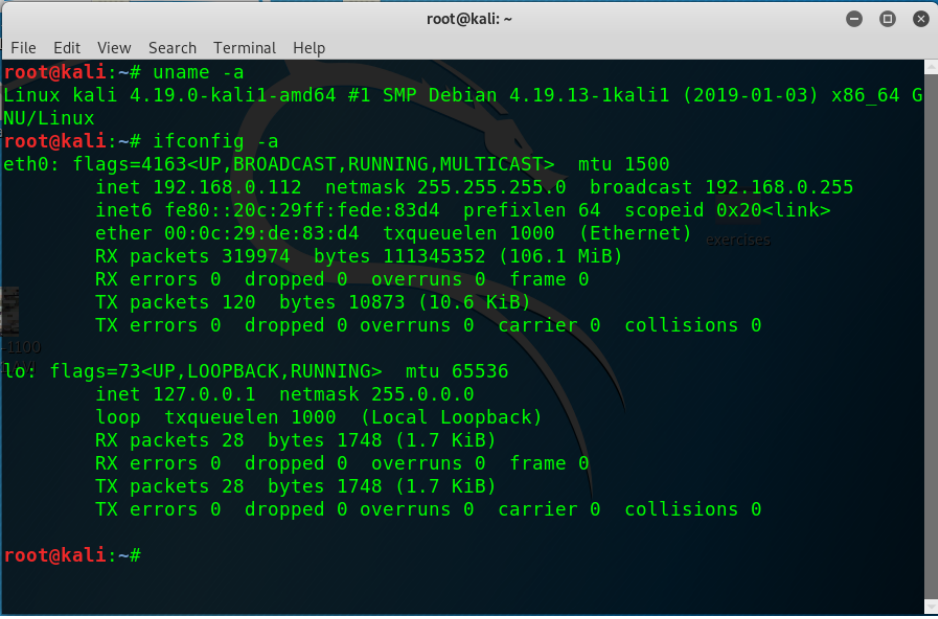

```
root@kali: ~  
File Edit View Search Terminal Help  
root@kali:~# uname -a  
Linux kali 4.19.0-kali1-amd64 #1 SMP Debian 4.19.13-1kali1 (2019-01-03) x86_64 GNU/Linux  
root@kali:~# ifconfig -a  
eth0: flags=4163<UP,BROADCAST,RUNNING,MULTICAST> mtu 1500  
inet 192.168.0.112 netmask 255.255.255.0 broadcast 192.168.0.255  
inet6 fe80::20c:29ff:fede:83d4 prefixlen 64 scopeid 0x20<link>  
ether 00:0c:29:de:83:d4 txqueuelen 1000 (Ethernet)  
RX packets 319974 bytes 111345352 (106.1 MiB)  
RX errors 0 dropped 0 overruns 0 frame 0  
TX packets 120 bytes 10873 (10.6 KiB)  
TX errors 0 dropped 0 overruns 0 carrier 0 collisions 0  
  
lo: flags=73<UP,LOOPBACK,RUNNING> mtu 65536  
inet 127.0.0.1 netmask 255.0.0.0  
loop txqueuelen 1000 (Local Loopback)  
RX packets 28 bytes 1748 (1.7 KiB)  
RX errors 0 dropped 0 overruns 0 frame 0  
TX packets 28 bytes 1748 (1.7 KiB)  
TX errors 0 dropped 0 overruns 0 carrier 0 collisions 0  
  
root@kali:~#
```

(Figure 1.Kali Linux)

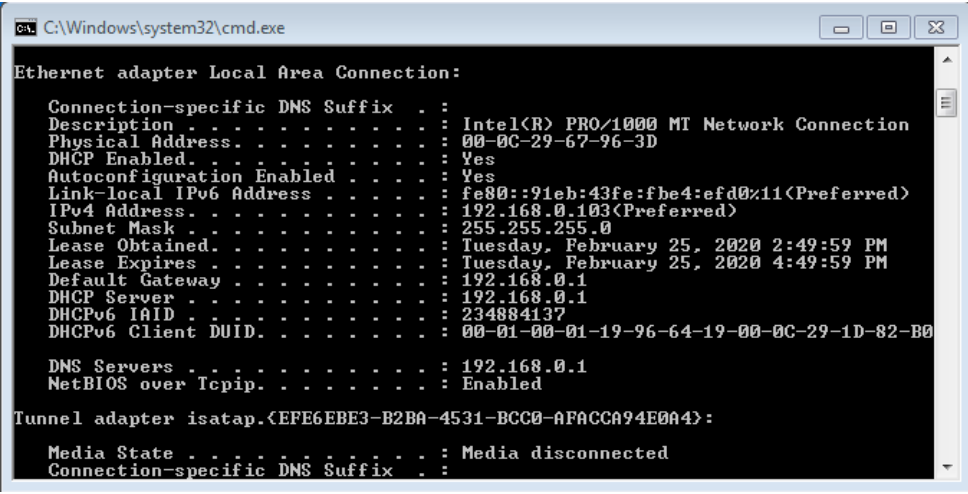

```
C:\Windows\system32\cmd.exe  
Ethernet adapter Local Area Connection:  
  
Connection-specific DNS Suffix . . :  
Description . . . . . : Intel(R) PRO/1000 MT Network Connection  
Physical Address. . . . . : 00-0C-29-67-96-3D  
DHCP Enabled. . . . . : Yes  
Autoconfiguration Enabled . . . . : Yes  
Link-local IPv6 Address . . . . . : fe80::91eb:43fe:fbe4:efd0%11<Preferred>  
IPv4 Address. . . . . : 192.168.0.103<Preferred>  
Subnet Mask . . . . . : 255.255.255.0  
Lease Obtained. . . . . : Tuesday, February 25, 2020 2:49:59 PM  
Lease Expires . . . . . : Tuesday, February 25, 2020 4:49:59 PM  
Default Gateway . . . . . : 192.168.0.1  
DHCP Server . . . . . : 192.168.0.1  
DHCPv6 IAID . . . . . : 234884137  
DHCPv6 Client DUID. . . . . : 00-01-00-01-19-96-64-19-00-0C-29-1D-82-B0  
  
DNS Servers . . . . . : 192.168.0.1  
NetBIOS over Tcpip. . . . . : Enabled  
  
Tunnel adapter isatap.{EFE6EBE3-B2BA-4531-BCC0-AFACCA94E0A4} :  
Media State . . . . . : Media disconnected  
Connection-specific DNS Suffix . . :
```

(Figure 2. Windows 7)

```
To access official Ubuntu documentation, please visit:
http://help.ubuntu.com/
No mail.
msfadmin@metasploitable:~$ ifconfig
eth0      Link encap:Ethernet  HWaddr 00:0c:29:37:85:e3
          inet addr:192.168.0.113 Bcast:192.168.0.255 Mask:255.255.255.0
          inet6 addr: fe80::20c:29ff:fe37:85e3/64 Scope:Link
          UP BROADCAST RUNNING MULTICAST  MTU:1500  Metric:1
          RX packets:44 errors:0 dropped:0 overruns:0 frame:0
          TX packets:67 errors:0 dropped:0 overruns:0 carrier:0
          collisions:0 txqueuelen:1000
          RX bytes:6028 (5.8 KB)  TX bytes:7186 (7.0 KB)
          Interrupt:17 Base address:0x2000

lo        Link encap:Local Loopback
          inet addr:127.0.0.1 Mask:255.0.0.0
          inet6 addr: ::1/128 Scope:Host
          UP LOOPBACK RUNNING  MTU:16436  Metric:1
          RX packets:91 errors:0 dropped:0 overruns:0 frame:0
          TX packets:91 errors:0 dropped:0 overruns:0 carrier:0
          collisions:0 txqueuelen:0
          RX bytes:19301 (18.8 KB)  TX bytes:19301 (18.8 KB)

msfadmin@metasploitable:~$
msfadmin@metasploitable:~$ _
```

(Figure 3. Metasploitable)

The first step in identifying the other systems within the created network is to use one of the Nmap or Zenmap utilities. Zenmap is the graphical interface for the Nmap utility.

This tool is intended to perform the scanning part of the network, sending SYN, ACK and REQ packets. Once the scan is done, open ports for communication, the operating system of the scanned systems, certain patterns that will help to exploit the respective systems will be identified so that a reverse reverse shell can be obtained on the system. victim.

The network mapping command is exemplified by the image below.

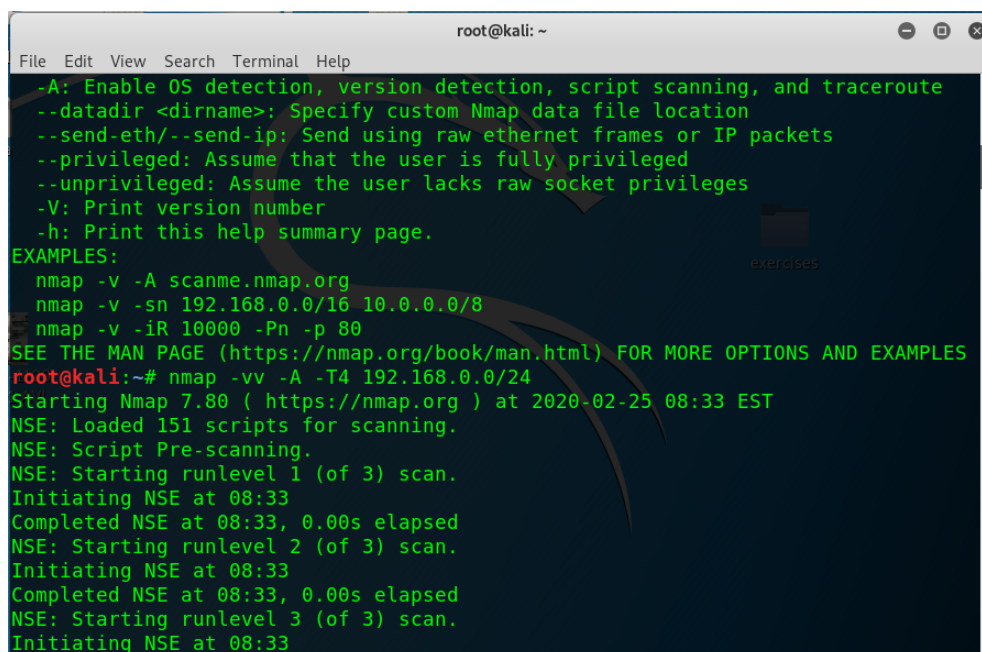

```
root@kali: ~
File Edit View Search Terminal Help
-A: Enable OS detection, version detection, script scanning, and traceroute
--datadir <dirname>: Specify custom Nmap data file location
--send-eth/--send-ip: Send using raw ethernet frames or IP packets
--privileged: Assume that the user is fully privileged
--unprivileged: Assume the user lacks raw socket privileges
-V: Print version number
-h: Print this help summary page.
EXAMPLES:
nmap -v -A scanme.nmap.org
nmap -v -sn 192.168.0.0/16 10.0.0.0/8
nmap -v -iR 10000 -Pn -p 80
SEE THE MAN PAGE (https://nmap.org/book/man.html) FOR MORE OPTIONS AND EXAMPLES
root@kali:~# nmap -vv -A -T4 192.168.0.0/24
Starting Nmap 7.80 ( https://nmap.org ) at 2020-02-25 08:33 EST
NSE: Loaded 151 scripts for scanning.
NSE: Script Pre-scanning.
NSE: Starting runlevel 1 (of 3) scan.
Initiating NSE at 08:33
Completed NSE at 08:33, 0.00s elapsed
NSE: Starting runlevel 2 (of 3) scan.
Initiating NSE at 08:33
Completed NSE at 08:33, 0.00s elapsed
NSE: Starting runlevel 3 (of 3) scan.
Initiating NSE at 08:33
```

(Figure 4. Mapping comand)

It contains the following parameters:

- vv, which is the verbose mode option, which helps to display the entire process that takes place during the scan;
- A, parameter that refers to an aggressive type scan, resulting in the determination of the operating system of the potential victim;
- T4, which increases the scan speed cycle
- all the ip in the 192.168.0.0 network, with a 24 bit mask.

### 3. The results obtained from the analysis

The results for Windows 7 and Metasploitable machines are shown in the images below.

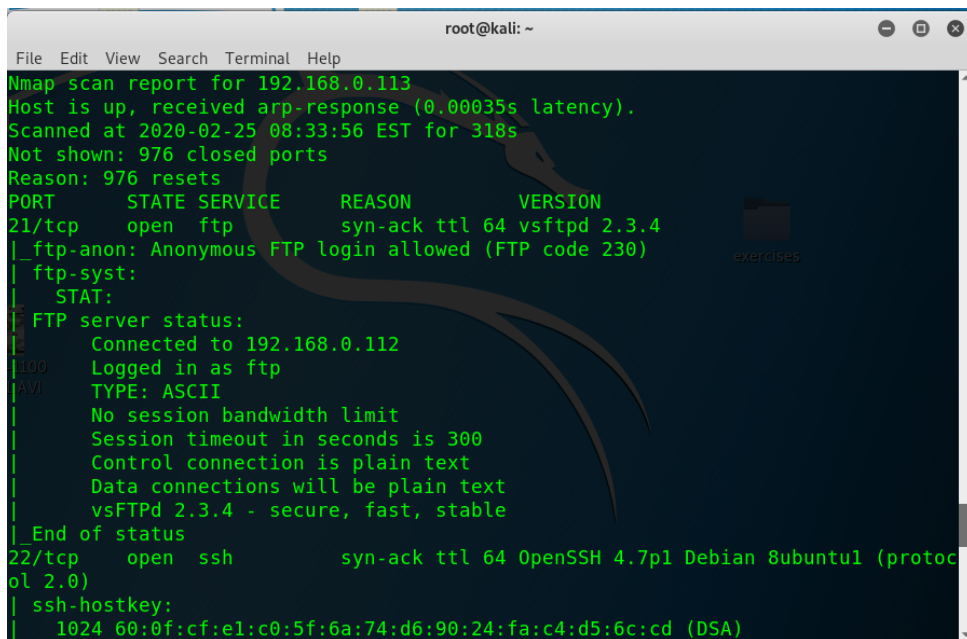

```
root@kali: ~  
File Edit View Search Terminal Help  
Nmap scan report for 192.168.0.113  
Host is up, received arp-response (0.00035s latency).  
Scanned at 2020-02-25 08:33:56 EST for 318s  
Not shown: 976 closed ports  
Reason: 976 resets  
PORT      STATE SERVICE      REASON      VERSION  
21/tcp    open  ftp          syn-ack ttl 64 vsftpd 2.3.4  
|_ ftp-anon: Anonymous FTP login allowed (FTP code 230)  
|_ ftp-syst:  
|   STAT:  
|   FTP server status:  
|     Connected to 192.168.0.112  
|     Logged in as ftp  
|     TYPE: ASCII  
|     No session bandwidth limit  
|     Session timeout in seconds is 300  
|     Control connection is plain text  
|     Data connections will be plain text  
|     vsFTPd 2.3.4 - secure, fast, stable  
|_ End of status  
22/tcp    open  ssh          syn-ack ttl 64 OpenSSH 4.7p1 Debian 8ubuntu1 (protocol 2.0)  
|_ ssh-hostkey:  
|   1024 60:0f:cf:e1:c0:5f:6a:74:d6:90:24:fa:c4:d5:6c:cd (DSA)
```

(Figure 5.Metasploitable scanning)

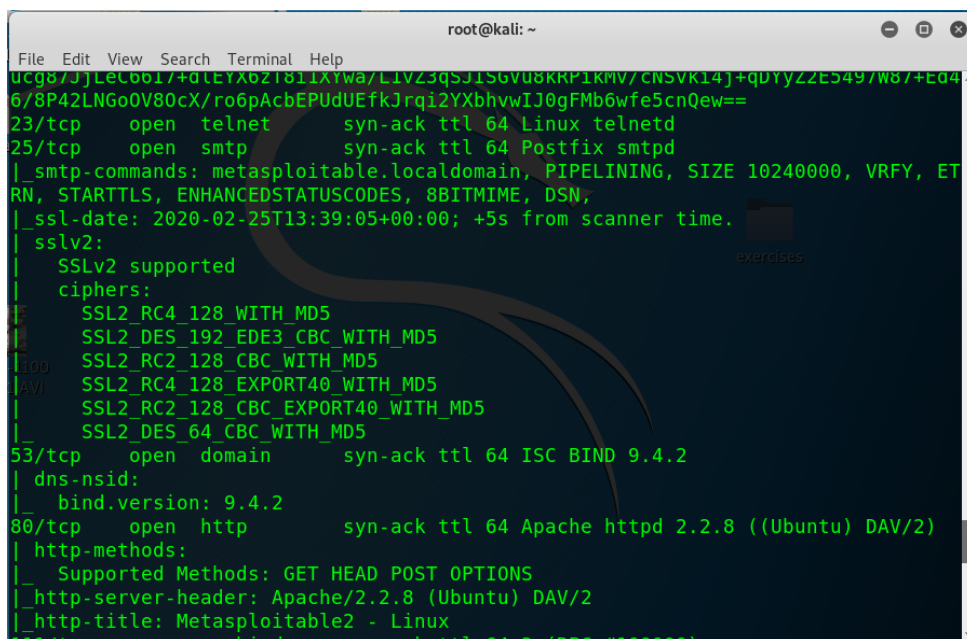

```
root@kali: ~  
File Edit View Search Terminal Help  
ucg8/JjLeC6b17+0tEYx0ZT811Xtwa/L1V23qSj15GVu8KRP1KMV/cNSVK14j+qDtyZ2E549/W8/+Ed4  
6/8P42LNGo0V80cX/ro6pAcBEPudUEfkJrqi2YXbhvwIj0gFMb6wfe5cnQew==  
23/tcp    open  telnet       syn-ack ttl 64 Linux telnetd  
25/tcp    open  smtp         syn-ack ttl 64 Postfix smtpd  
|_ smtp-commands: metasploitable.localdomain, PIPELINING, SIZE 10240000, VRFY, ET  
RN, STARTTLS, ENHANCEDSTATUSCODES, 8BITMIME, DSN,  
|_ ssl-date: 2020-02-25T13:39:05+00:00; +5s from scanner time.  
|_ sslv2:  
|   SSLv2 supported  
|   ciphers:  
|     SSL2_RC4_128_WITH_MD5  
|     SSL2_DES_192_EDE3_CBC_WITH_MD5  
|     SSL2_RC2_128_CBC_WITH_MD5  
|     SSL2_RC4_128_EXPORT40_WITH_MD5  
|     SSL2_RC2_128_CBC_EXPORT40_WITH_MD5  
|     SSL2_DES_64_CBC_WITH_MD5  
53/tcp    open  domain       syn-ack ttl 64 ISC BIND 9.4.2  
|_ dns-nsid:  
|_ bind.version: 9.4.2  
80/tcp    open  http         syn-ack ttl 64 Apache httpd 2.2.8 ((Ubuntu) DAV/2)  
|_ http-methods:  
|_ Supported Methods: GET HEAD POST OPTIONS  
|_ http-server-header: Apache/2.2.8 (Ubuntu) DAV/2  
|_ http-title: Metasploitable2 - Linux
```

(Figure 6.Metasploitable scanning)

```

root@kali: ~
File Edit View Search Terminal Help
Host script results:
  _clock-skew: mean: 4s, deviation: 0s, median: 4s
  _ms-sql-info: ERROR: Script execution failed (use -d to debug)
  nbstat: NetBIOS name: METASPLOITABLE, NetBIOS user: <unknown>, NetBIOS MAC: <unknown> (unknown)
  Names:
    METASPLOITABLE<00>   Flags: <unique><active>
    METASPLOITABLE<03>   Flags: <unique><active>
    METASPLOITABLE<20>   Flags: <unique><active>
    WORKGROUP<00>        Flags: <group><active>
    WORKGROUP<1e>        Flags: <group><active>
  Statistics:
    00 00 00 00 00 00 00 00 00 00 00 00 00 00 00 00
    00 00 00 00 00 00 00 00 00 00 00 00 00 00 00 00
    00 00 00 00 00 00 00 00 00 00 00 00 00 00 00
  p2p-conficker:
    Checking for Conficker.C or higher...
    Check 1 (port 55350/tcp): CLEAN (Couldn't connect)
    Check 2 (port 65416/tcp): CLEAN (Couldn't connect)
    Check 3 (port 18694/udp): CLEAN (Failed to receive data)
    Check 4 (port 29091/udp): CLEAN (Failed to receive data)
    0/4 checks are positive: Host is CLEAN or ports are blocked
  _smb-os-discovery: ERROR: Script execution failed (use -d to debug)
  _smb-security-mode: ERROR: Script execution failed (use -d to debug)

```

(Figure 7. Metasploitable scanning)

These images give us brief insights into vulnerabilities in the Linux operating system, Metasploit distribution. We can see most of the communication ports open, namely ports 22 and 23, SSH and TELNET, port 80 for HTTP, and 21 for file transfer, FTP.

In the last image you can see the determination of the operating system, nmap being able to identify that the scanned machine is one of Metasploit.

For the Windows 7 machine, the scan results are illustrated using the image below.

```

root@kali: ~
File Edit View Search Terminal Help
IE(R=N)
Network Distance: 1 hop
TRACEROUTE
HOP RTT ADDRESS
1 0.33 ms 192.168.0.103
NSE: Script Post-scanning.
NSE: Starting runlevel 1 (of 3) scan.
Initiating NSE at 09:19
Completed NSE at 09:19, 0.00s elapsed
NSE: Starting runlevel 2 (of 3) scan.
Initiating NSE at 09:19
Completed NSE at 09:19, 0.00s elapsed
NSE: Starting runlevel 3 (of 3) scan.
Initiating NSE at 09:19
Completed NSE at 09:19, 0.00s elapsed
Read data files from: /usr/bin/./share/nmap
OS and Service detection performed. Please report any incorrect results at https://nmap.org/submit/ .
Nmap done: 1 IP address (1 host up) scanned in 24.59 seconds
Raw packets sent: 2049 (94.700KB) | Rcvd: 1 (28B)
root@kali:~#

```

(Figure 8.Windows 7 scanning)

Once the part of the reconnaissance and information gathering is over, the final part is to gain access to the victim's system, so that in the end we can eliminate all the possible traces we can leave. The area of investigation of the attack on the system already falls within the scope of threat hunting and is coming out of the cyber war zone, so the analysis part and even the attack part will not be treated in this part.

## **5. Conclusion**

As it can be seen in the above, it is not very difficult to detect the operating system of a possible victim, everything is in the level of preparation of the one who wants to find vulnerabilities.

That is why all the companies with a reputation in the IT field are looking for the most trained programmers to design, test, verify and remedy any errors of the programs created by them.

In conclusion, although a system operates on the basis of automated principles, it will always be vulnerable to a few, because it is the man who programs it. However, it is all the man who identifies the breaches and removes them or, on the contrary, takes advantage of them.

## **BIBLIOGRAPHY**

- Daniel W . Dieterle , „Basic Security Testing with Kali Linux”, 2013  
Beggs, Robert W., „Mastering Kali Linux for Advanced Penetration Testing”, Packet Publishing Ltd, 2014

# ANTENNA'S VSWR MEASUREMENT SYSTEM WITH RTL-SDR

Sebastian Mihai FERNEA

“Nicolae Bălcescu” Land Forces Academy, Sibiu, Romania

[s.fernea@yahoo.com](mailto:s.fernea@yahoo.com)

Scientific coordinator: Assist.Prof.Eng. Iulian BOULEANU, PhD

***Abstract:** The main objective of this study is to propose an alternative variant of a VSWR-meter, a variant that any radio passionate about this phenomenon can realize and use but which does not allow the purchase of the latest generation equipment. This study also comes as an aid providing the necessary explanations and conclusive examples to eliminate any doubt.*

*The first chapter will present the VSWR principle in the transmission of information and some general notions about this theory. Of all the antenna losses, this study aims to analyze one, namely the VSWR.*

*In the second chapter we will consider the importance of each component and make measurements in optimal conditions so that the results obtained are close to those desired. The environment in which these measurements will be carried out will be the laboratory, this being as far as possible without other sources that will disturb or influence the desired results.*

**KEYWORDS:** VSWR, radio, antenna, RTL-SDR, signal

## HOW CAN WE MEASURE VSWR OF AN ANTENNA?

The purpose of this article is to perform a comparative study and to appreciate the degree of confidence that can be given to an improvised software that targets the difference of the VSWR to different antennas based on all the accumulated results. The study was possible due to the measurements made in the laboratory, on the Omnilog 70600 antenna, with the help of 3 instruments, namely the programmable synthesizer generator HM8134-3, a coaxial bidirectional coupler model 3020A and an RTL-SDR stick.

During the article I will present how to use the devices used and their interconnection so that the necessary measurements can be made to the work requirement. Although a much more precise and faster measurement can be done with the help of a VSWR-meter on the market, but by the chosen variant one wishes to approximate the results obtained with those high performance devices. Of course, another objective of this method of measurement is represented by the cost required to achieve it, being much lower than any VSWR meter on the market.



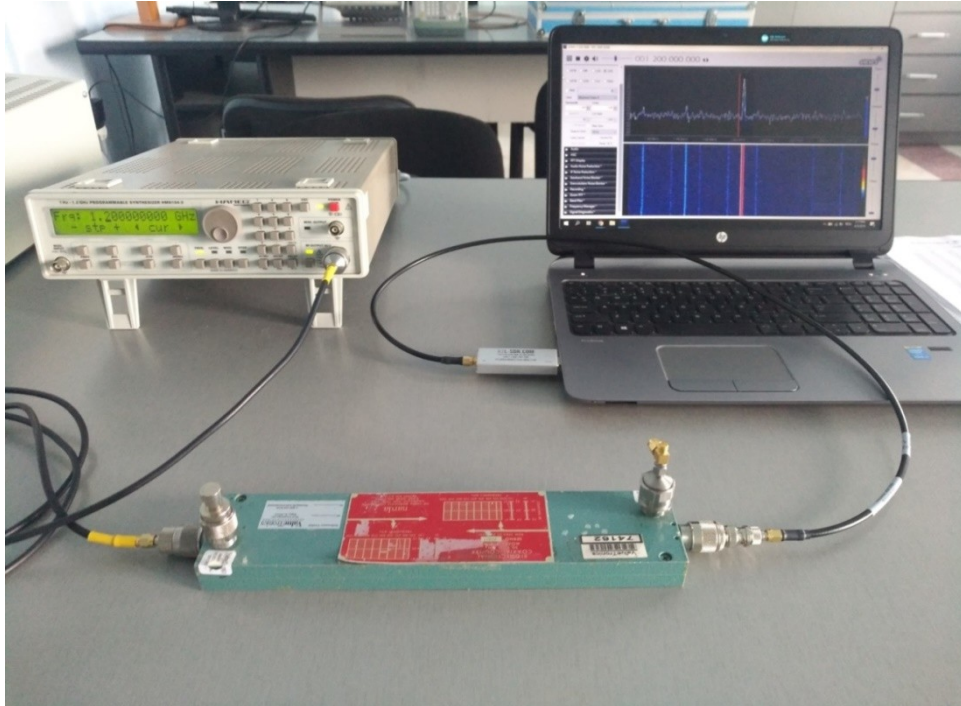

*Figure 1 - Testing the system without antenna*

In this case, there is a bidirectional shielded coupler, which implies minimal losses. In order to check the coupling and to make the measurements it is necessary to use a resistor, in this case a  $50\ \Omega$  was used. cable that connects the coupler to the stick. It will be tracked if the generated signal goes through the coupler and reaches the SDR-Sharp program. On the other hand, the difference between the signal reached in the program without passing through the coupling and the signal reached in the program passed before through the coupling will be analyzed. Thus, the influence of the coupler in transmitting the signal can be truly established. The figure below shows the signal obtained without an antenna at the frequency of 800 MHz.

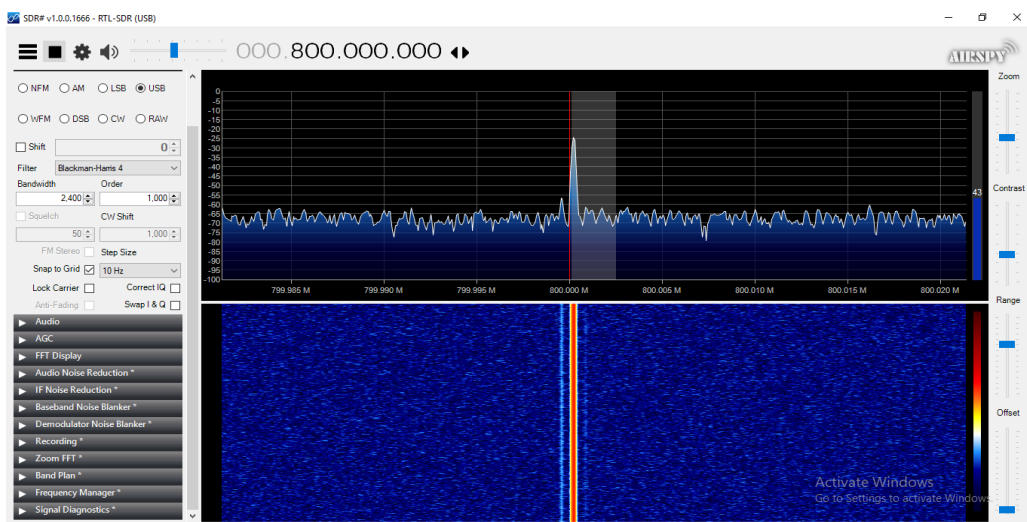

*Figure 2 – Testing the SDR-Sharp program*

Measurements with this type of antenna, as with the others, are made by manually entering the frequencies on the generator and on the laptop. Thus, the minimum antenna frequency was selected, namely 680 MHz and the maximum generator frequency, 1200MHz. This band was split so that it was a 10 MHz gap. This process was carried out without mounting the antenna in the first part, after which the measurements were repeated at the same frequencies as the mounted antenna. All the results were noted in an Excel to calculate the VSWR of that antenna there. As shown in the figure (see Figure 3.) and as the theory shows, the signal is emitted from the generator, passes through the coupler and reaches the antenna. However, it is known that no antenna is perfect, so it has some losses. One of them is the reflected part of the antenna, which returns to the generator. A small part of this goes through the DUT terminal on the laptop and can be measured to calculate the amount of reflected signal. The VSWR is only one of the losses that the antenna presents. Even the VSWR measured with this model has some leaks, either by the exact failure of the jacks or the cable connecting the devices. However, they try to avoid as much as possible their appearance, paying more attention to the connection of the devices or when choosing the cables used.

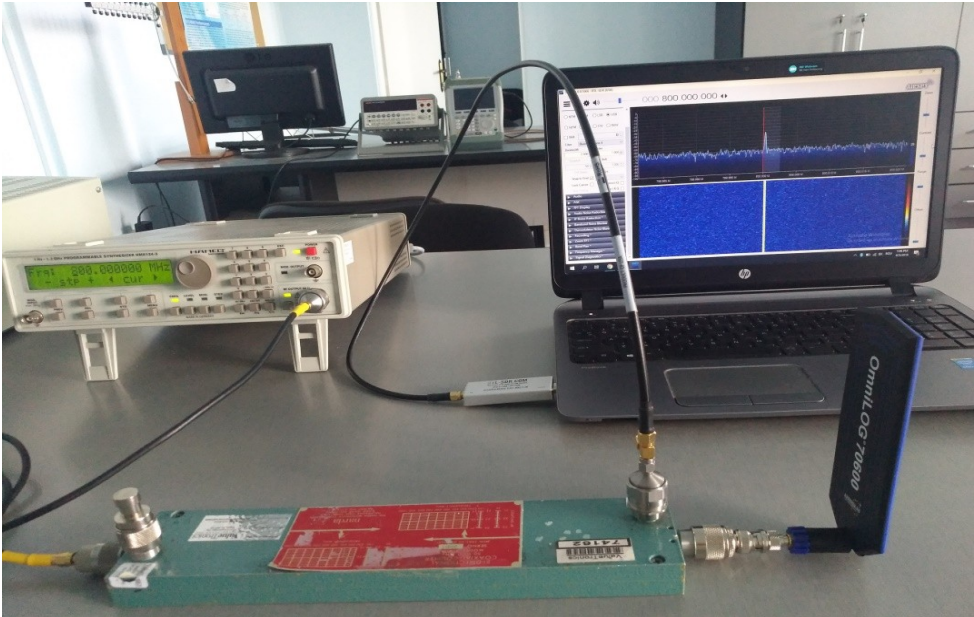

Figure 3 – Measurements with Omnilog 70600 antenna

In the figure below (see Figure 4) the information presented above is practically materialized. The frequency range starts at 680 MHz and ends at 1200MHz. It can be seen that the values measured without antenna are around -30 dB, while after installation the antenna values are smaller, around -40 dB or even smaller. When calculating the Return Loss and the VSWR, it turns out that this antenna has quite low losses until just before the stop frequency. This thing recommends the use of the antenna at frequencies lower than 1100 MHz for higher efficiency. On the right side of the figure (see Figure 4). We can see the resulting graph based on VSWR calculations.

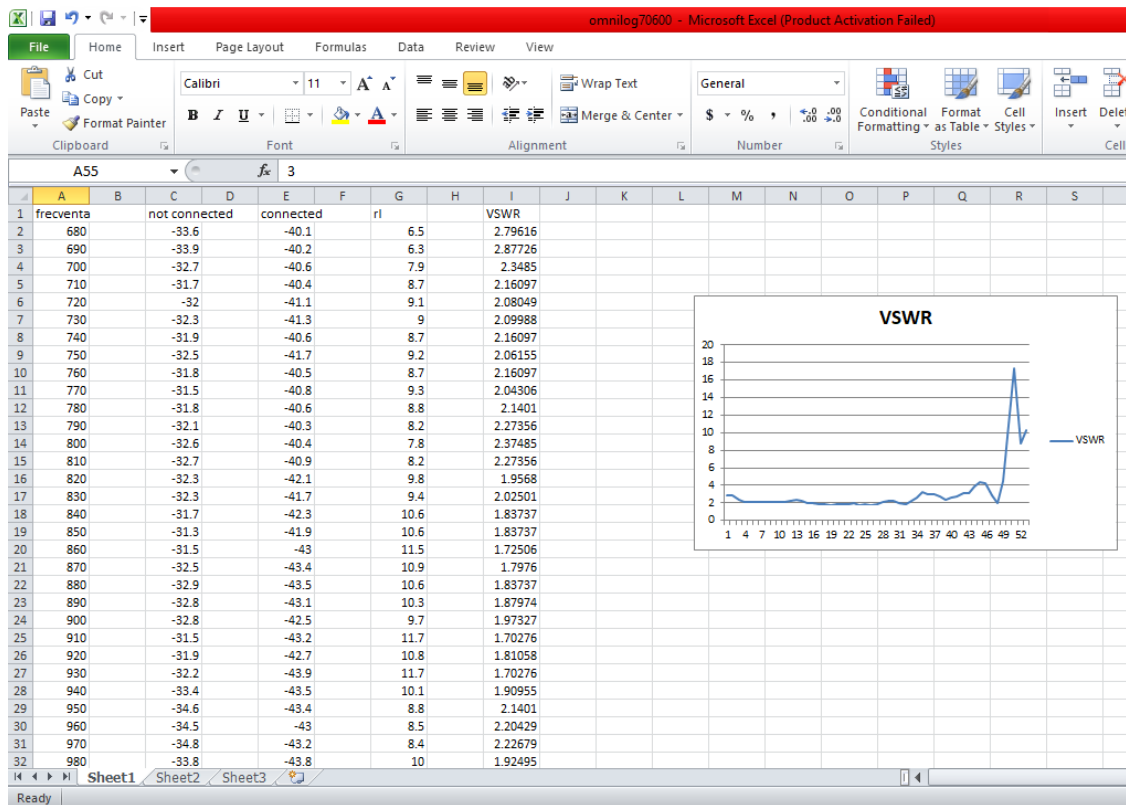

Figure 4 - Graph in excel with measured values of Omnilog 70600 antenna

It is noted that the Return Loss for the first frequency has a value of 6.5. And as the frequency increases, it also increases, resulting in a decrease in the VSWR until the end of the graph where the VSWR increase is seen.

In order to be able to observe differences in losses between the Omnilog 70600 antenna and other antennas we used the Matlab software. This program allows to take ideas from research to production, by implementing enterprise applications and embedded devices, as well as by integrating with Simulink models and model-based design. So, I used the Omnilog 90200 antenna and the RG dipole antenna. This is a practical example of using this application. Note in this case (see Figure 2.6.5.) All 3 types of antennas selected. Introducing the 200MHz start frequency and the 1199 stop frequency, a pass through the entire band where the measurements were made. An example of VSWR measurement has also been shown, for a return loss of value 10. Returning to the graph, it shows all 3 signals but displays them in different colors, which is an aid in signal differentiation. With purple, the RG174 antenna signal is displayed, which crosses the entire selected band. With green, starting only at the frequency of 680 MHz, the signal of the Omnilog 90200 antenna is played. Finally, with blue is the antenna with the range, with which the measurements were made, the smallest. This is the Omnilog 70600 antenna. It is obvious that the VSWR for the RG 174 antenna is very high up to the frequency of 680 MHz. From this frequency the VSWR is balanced, even at some points the lowest values are compared to the other two antennas.

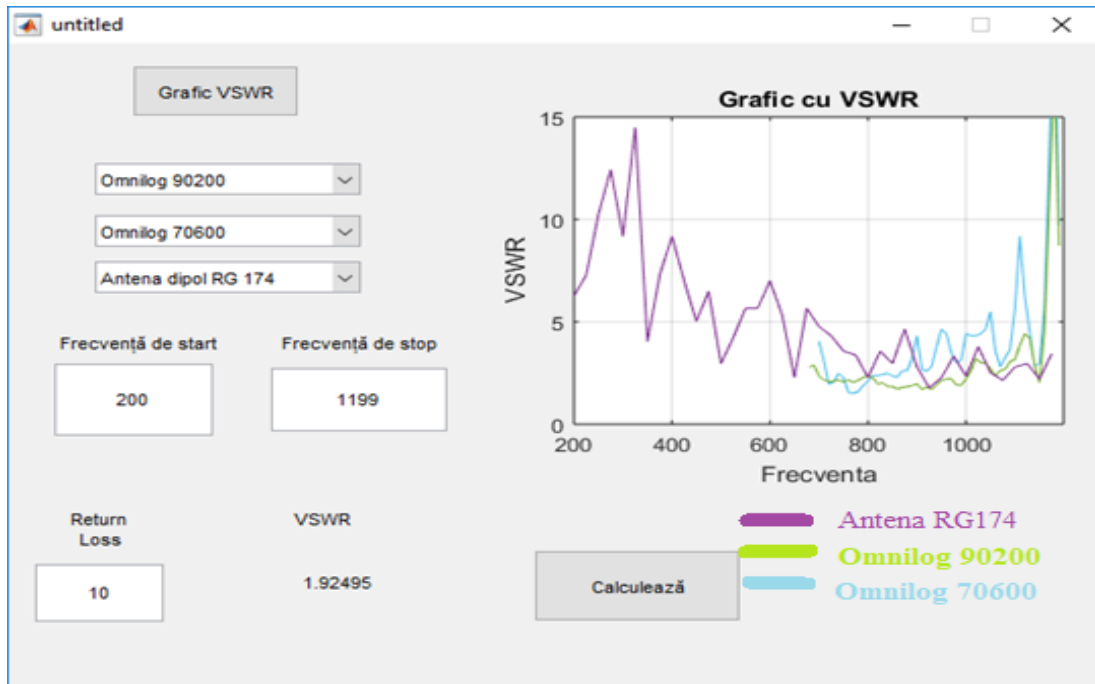

Figure 5 – Measurement with Matlab

## CONCLUSION

In this article we have made an overview of the instruments with which we have performed measurements to determine the VSWR level on the Omnilog 70600 antenna and a comparison with the 2 antenna alternatives. In turn, the Omnilog 70600 antenna is a recommended antenna, as it has a VSWR approximately constant in the 700-1200 MHz working range. However, none of the three antennas is able to reproduce the reality in a proportion of 100% because they have quite high losses but within the limits of the measurements. In order to provide results as close to reality as possible, improvements should be made in terms of connecting devices and using an environment that does not provide antenna influences.

## BIBLIOGRAPHY

- [1] Stoianovici, V.C., Nedelcu, A.V., *A Software Defined Radio approach to spectrum sensing systems architecture*, Braşov, în:*Buletinul Universităţii Transilvania*”, nr.1, vol.4, 2011.
- [2] Darrin Walraven, *Understanding SWR by Example*, 2006.
- [3] <https://www.aaronia.com/products/antennas/Omnilog-70600-Omni-Directional-Antenna/>
- [4] <https://www.rtl-sdr.com/rtl-sdr-tutorial-measuring-filter-characteristics-and-antenna-vswr-with-an-rtl-sdr-and-noise-source/>
- [5] <https://www.rtl-sdr.com/rtl-sdr-quick-start-guide/>
- [6] <https://www.amphenolrf.com/faq/technical/what-is-the-difference-between-return-loss-and-vswr.html>

# STUDY ON THE INFLUENCE OF PROPAGATION CONDITIONS ON SOME WAVEFORMS USED IN COMMUNICATIONS SYSTEMS WITH SPECIAL APPLICATION

Daniel GALDEA

“Nicolae Bălcescu” Land Forces Academy, Sibiu  
galdea.daniel27@gmail.com

Scientific coordinator: CPT Assist.Prof. Annamaria SĂRBU, PhD

**Abstract:** *One of the most important aspect of modern warfare is the information supremacy, which can only be obtained by reliable and high performance communication networks. In this article the autor proposed the use of four propagation prediction models, the free space path loss model, Hata, Cost 231 and Egli models to calculate the path loss of VHF bandwidth radio frequency signals and choose which one is more accurate for radio communications in an urban area. An analysis of the path loss has been provided using a signal generator, a spectrum analyzer and two dipole antennas. Signal was measured and compared over multiple distances(from 15 to 225 meters) using a set of 7 frequencies selected based on antenna VSWR measurements.*

**Keywords:** VHF, Propagation, path loss, Hata model.

## 1. Introduction

In the last decades, the information supremacy became one of the most important aspect of modern warfare, due to the fact that the battlefield requires higher distances between units and also a high mobility of forces, which can only be obtained with faster, more efficient and secure communications. To obtain more efficient communications, propagation prediction models where developed to help radio networks managers in creating and upgrading radio networks by establishing optimal characteristics required depending on the terrain, forces, mission and other aspects. This models are successfully used to estimate the radio network dimensions, select the appropriate type of antenna, or frequencies for a certain area, all to ensure an undisturbed and high quality radio connection.

The Very High Frequencies (VHF) range, going from 30MHz up to 300MHz, with corresponding wavelengths of 10 meters to 1 meter, is the most common in military communications. In the Romanian Army, Harris 5800 V and 7800 transceivers are the most used. One of the VHF radiowaves characteristics is the fact that they propagate mainly by line-of-sight and ground-bounce paths. VHF radiowaves propagate into the troposphere, where the trajectory suffers a deflection under a small angle, due to the tropospheric refractive index. The VHF frequencies can easily be used for communications over short distances 1-10

Km, but also for higher distances, up to 150 Km with maximum power and very good propagation conditions.

The value of a propagation prediction model consists of its ability to reduce the costs, time and also the number of personnel required for developing a network, while also maintaining high standards. A propagation prediction model provides the means to choose the locations where stationary radio stations are installed, to plan patrol routes using areas with good signal coverage, in order to provide stable, fast and secure links. Without these models, the only option would be to create and then test it, an option which doesn't offer a high rate of success and also requires multiple trials to establish optimal parameters of the network.

In this study, four propagation prediction models were used to analyse the path loss of radio signal over distance. The first is the free space path loss model(FSPL) which is a theoretical model, that does not take into calculation the characteristic of different areas. Hata and Cost 231 are two empirical models used. They are based on measurements and real observations of the signal. This type of propagation prediction models use environment characteristics such as height and density of buildings, height of antennas and also characteristics of the transmitter and receiver. The forth propagation prediction model, the Egli model is a terrain model, which is suitable for scenarios where one antenna is fixed and the other is mobile [1].

## **2. Materials and methods**

To complete this study, measurements are made at the "Nicolae Bălcescu" Land Forces Academy, consisting of 15 points placed at 15 m distance from each other, and 7 frequencies which are chose based on antenna VSWR measurements. In order to complete them, the R&S SM300 signal generator was used as a transmitter together with the VHA 9103 dipole antenna and the spectrum analyzer HF 6060 V4 together with the UBAA 9115 dipole antenna as a receiver.

The R&S SM300 signal generator is ideal to generate high quality signals, with the option to choose the power of the signal, the frequency, which can go from 9 kHz to 3 GHz, the bandwidth, the modulation type(AM, FM, phase modulation, pulse modulation). It is a small sized signal generator, which means it is suited for both indoor and outdoor work, with an easy to use interface [2]. The Aaronia SPECTRAN HF-6060 V4, is an ideal spectrum analyzer thanks to the small size, and especially because of the high level of precision. It is also a portable analyzer, which makes it perfect for this study. It can analyze frequencies from 10 MHz to 6 GHz, while also being able to demodulate AM/FM signals [3].

The Schwarzbeck UBAA 9115 is a dipole antenna vertically polarized which can work between 30 MHz and 1200 MHz, with a maximum power of 5W [4].

The Schwarzbeck VHA 9103 is a dipole antenna vertically polarized, which works between 30 MHz and 300 MHz and with a maximum power of 10W [5].

To select the 7 frequencies, the VHA 9103 antenna is connected to the spectrum analyzer through the R&S FSH-Z2 VSWR bridge. According to the VSWR graph displayed in the VHF spectrum range we have selected the test frequency values(optimal VSWR, smaller read values). The frequencies values are: 40, 75, 110, 150, 190, 240 and 300 MHz. After chosing the frequencies, the next step was to prepare the emission and receiver systems, the signal generator, the spectrum analyzer and the two antennas, one stationary and the other mobile, placed at a height of 1 m from the ground. For optimal results, the maximum power of +13dBm was used. The emission system is represented in Figure no. 1.



Figure no. 1: The transmitter system

After making the measurements, the path loss for each frequency and distance was calculated (Table no. 1) with the following formula:

Loss = the power emitted - the received power + emission antenna gain + receiving antenna gain

**Table no.1**  
Path loss

Distance	Loss (dB)						
	f1=40 MHz	f2=75 MHz	f3=110 MHz	f4=150 MHz	f5=190 MHz	f6=240 MHz	f7=300 MHz
15	16.68	33.06	48.13	45.75	51.28	44.77	53.03
30	14.68	32.06	49.13	60.75	66.28	56.77	62.03
45	22.68	34.06	43.13	62.75	60.28	65.77	70.03
60	21.68	35.06	42.13	68.75	63.28	64.77	70.03
75	21.68	37.06	43.13	60.75	62.28	74.77	70.03
90	21.68	34.06	41.13	66.75	70.28	71.77	74.03
105	37.68	25.06	39.13	60.75	63.28	67.77	62.03
120	26.68	41.06	46.13	60.75	63.28	66.77	62.03
135	24.68	41.06	46.13	59.75	63.28	67.77	62.03
150	25.68	39.06	43.13	59.75	63.28	68.77	62.03
165	26.68	40.06	37.13	70.75	65.28	75.77	77.03
180	27.68	42.06	45.13	70.75	68.28	77.77	77.03
195	26.68	39.06	48.13	67.75	65.28	77.77	79.03
210	28.68	34.06	46.13	61.75	66.28	77.77	78.03
225	24.68	35.06	47.13	60.75	63.28	72.77	74.03

To simulate path losses of the signals using the FSPL, Hata, Cost-231 and Egli models, a GUI application made in the MATLAB software was used (Figure no. 2). The application calculates the path loss for each of the 7 frequencies and 15 distances, with the formula of each of the four propagation prediction models.

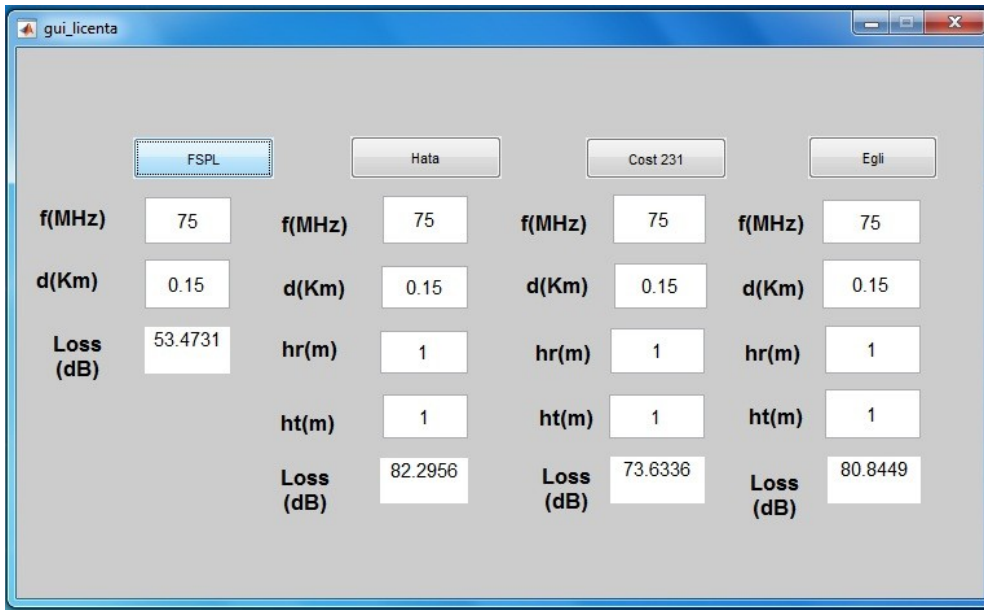

Figure no. 2: GUI application

### 3. Results and discussions

For a better comparison between the results obtained from measurements and from simulations, for each frequency is used a chart which contains the Path loss for each one of the 7 frequencies measurements and simulations. In the following chart (Figure no. 2), for the 40MHz frequency, Cost 231(from 19,35 to 72dB) and FSPL(from 39,48 to 57 dB) models provide the closest results to the ones from the measurements (from 14,68 to 37,68 dB) .

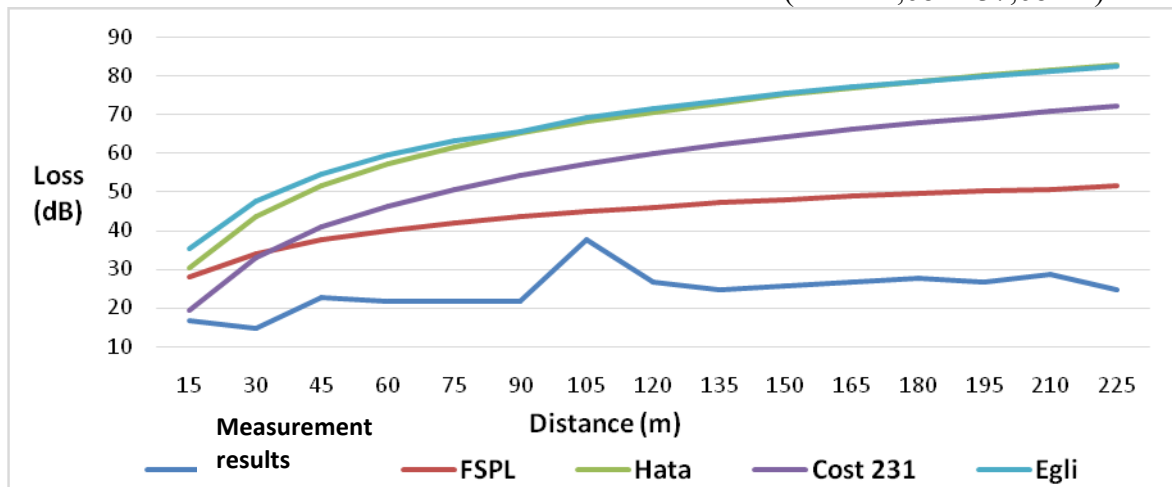

Figure no. 3: Path loss chart for 40 MHz

For the 75 MHz frequency, the measured path loss obtained goes from 25 to 45 dB, with constant values. The first and the last point values are relatively the same, 33 and 35 dB. The FSPL model provides the closest results to the ones from measurements.



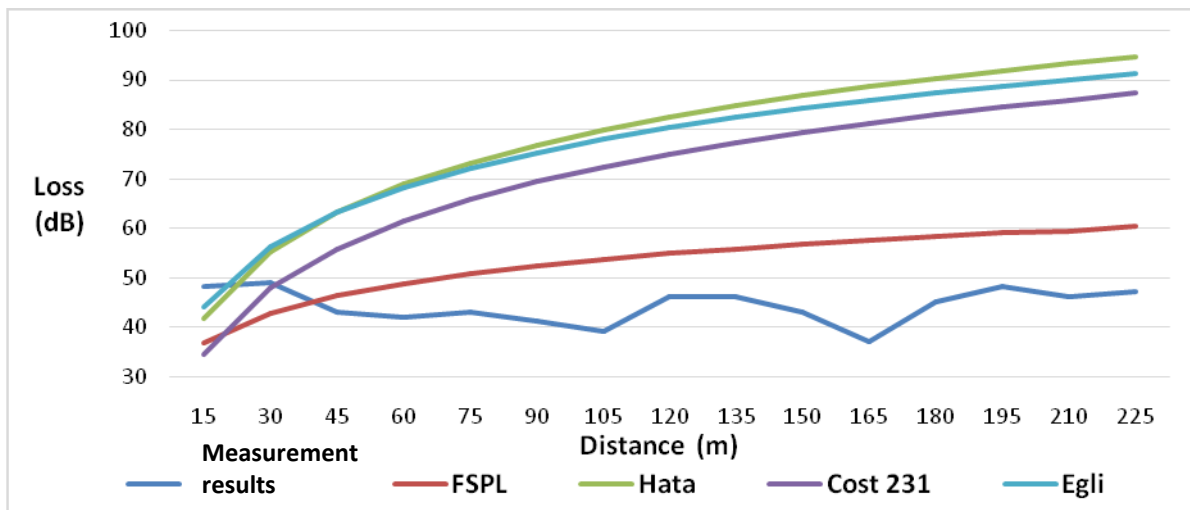

Figure no. 4 Path loss chart for 110 MHz

In Figure no. 3, the chart for the 110 MHz frequency shows that for the first distances, the Hata, Egli and FSPL models provide similar values, but for further distances the FSPL provides better results. For the frequency of 150MHz (Figure no. 5), Egli and Cost 231 provide the closest results to the measured ones (values which grow constantly for the first distances, and then decrease on further distances), while the FSPL provides lower ones.

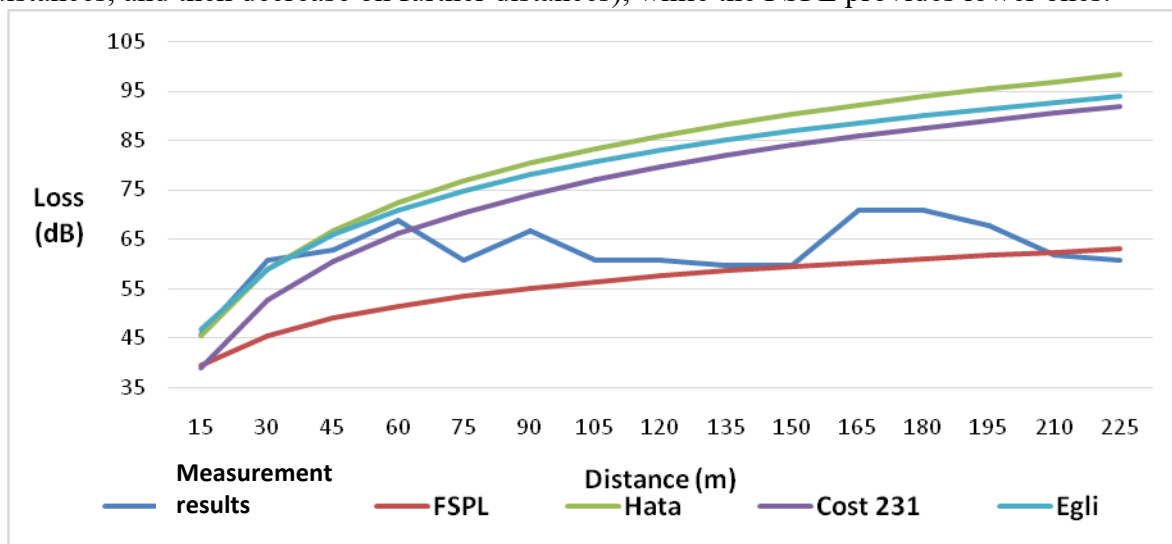

Figure no. 5: Path loss chart for 150 MHz

Using the frequency of 190 MHz, values are similar to the ones from the previous frequency. The FSPL provides lower values, while the Cost 231 model provides the best results.

For the 240 MHz frequency (Figure no. 5), the Hata, Egli and Cost 231 models predict values which are similar to the ones from measurements. The FSPL models once again predicts lower values of the path loss, due to the fact that it does not take into consideration obstacles, buildings or vegetation.

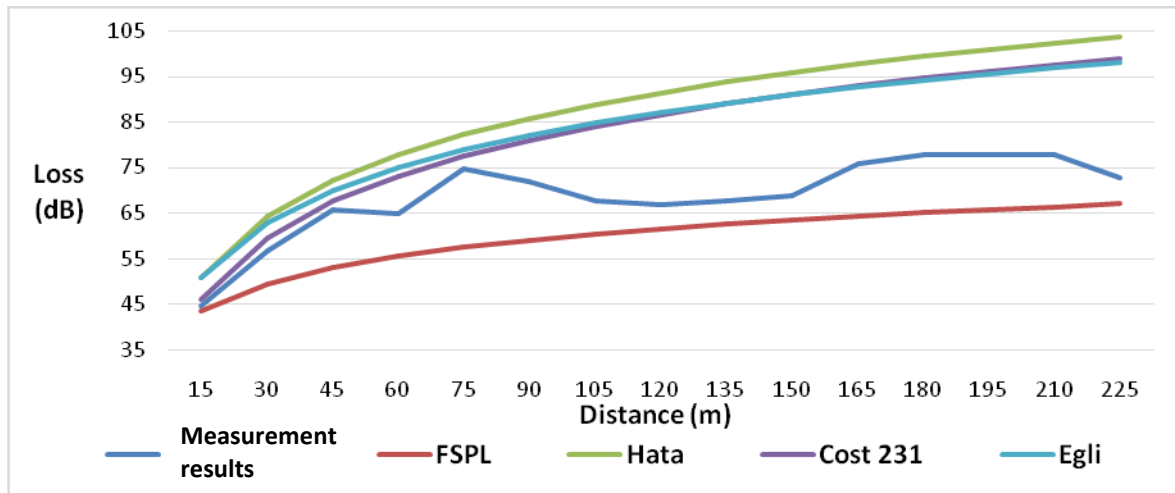

Figure no. 6: Path loss chart for 240 MHz

Using the frequency of 300 MHz, the FSPL model predicts lower values than the measured values, while the Hata, Egli and Cost 231 models manage to predict similar values with the measured ones for the first 6 distances.

#### 4. Conclusions

By analyzing the 7 frequencies charts, it is observed that the Hata, Cost 231, and Egli models predict values similar to the ones from the measurements, especially for the first 5-6 distances, while on further distances the Cost 231 model predicts the best values. The FSPL model does not predict good values on higher frequencies and distances, because it does not take into calculation parameters such as buildings density, vegetation, and other obstacles which are common in an urban area.

We can see that propagation prediction models are able to predict values for radio signals path loss, but with errors, due to the fact that urban areas are different from one to another. It is clear that for better predictions, which can help us build better networks, upgrades are needed for the propagation prediction models, so that they can be used for more frequency ranges, and with better precision.

#### REFERENCES

- [1] K. Fujimoto, J.R. James, *Mobile Antenna Systems Handbook*, Norwood, ARTECH HOUSE, 1994, 29.
- [2][https://cdn.rohdeschwarz.com/pws/dl\\_downloads/dl\\_common\\_library/dl\\_brochures\\_and\\_datasheets/pdf\\_1/SM300\\_dat\\_en.pdf](https://cdn.rohdeschwarz.com/pws/dl_downloads/dl_common_library/dl_brochures_and_datasheets/pdf_1/SM300_dat_en.pdf).
- [3]<https://www.aaronia.com/products/spectrum-analyzers/HF-6060-V4-RF-Spectrum-Analyzer/>.
- [4] <http://schwarzbeck.de/Datenblatt/k9115.pdf>.
- [5] <http://schwarzbeck.de/Datenblatt/k9103.pdf>.

#### BIBLIOGRAPHY

- A. Ignea, E. Mârza, Aldo de Sabata, *Antene și propagare*, Timișoara, Editura de Vest, 2002.
- Radu Munteanu, Iulian Bouleanu, *Rețele radio cu mobilitate ridicată*, Cluj-Napoca, Mediamira, 2013.
- Abot O., Simeon O., Afolayan J., *Comparative Analysis Of Path Loss Prediction Models For Urban Macrocellular Enviroments*, Nigeria, Department of electrical/electronics and computer engineering, University of Uyo, Akwa Ibom State, 2011.

Barry McLarnon, *VHF/UHF/Microwave Radio Propagation: A Primer for Digital Experimenters*, Ottawa, 1997.

Henning F. Harmuth & Malek G. M. Hussain, *Propagation of Electromagnetic Signals*, Singapore, editura World Scientific, 1994 .

# THE NECESSITY OF RECALCULATING THE CORRELATION BETWEEN THE PERFORMANT SYSTEMS AND MEANS OF STRIKING AND THE COMPONENT OF THE GENERAL PROTECTION SYSTEM IN THE OPERATIONS OF THE LAND FORCES, REPRESENTED BY FIELD FORTIFICATION

Gheorghiuță-Dragoș GIUBEGA

“Nicolae Bălcescu” Land Forces Academy, Sibiu

d.61uby@yahoo.com

Scientific coordinator: Prof. Mircea VLADU, PhD

**Abstract:***In this new era of technology the enlightened minds of strategists from modern armed country forces, have convinced the Political-Military representatives to invest a significant part of the country's Gross domestic product (GDP) in designing new technology and to start developing performant systems and means of striking for endowment of both air and land forces. This new equipments that were developed are represented by nuclear ammunition, intelligent ammunition such as warhead fitted with infrared, proximity or magnetic fuses, unmanned combat aerial vehicle (UAV), combat recognition drones and autonomous or remote-controlled robots. The present desire of armies General Staff for carrying out the engineering support, underlines the necessity for mechanized endowment in order to carry out the works of field fortification in the shortest possible time and with the use of minimum resources but also the use of specific modular buildings and facilities for the Command Headquarter.*

**Keywords:** field fortifications, military interoperability, technology.

In this new era of technology the enlightened minds of strategists from modern armed country forces, have convinced the Political-Military representatives to invest a significant part of the country's Gross domestic product (GDP) in designing new technology and to start developing performant systems and means of striking for endowment of both air and land forces.

NATO and EU member, Romania has a total area of 238397 km<sup>2</sup>, gadering between its borders all types of relief forms, that are crossed by a large hydrometric system collected by the river Danube, that overflows into the Black sea offering access to the planetary ocean.

At first sight we can say, that because it is situated in the extreme eastern side of NATO, Romania has an important advantage, due to the complexity of the territory, which can offer a great possibility to organize and conduct strategic and tactical operations with success

regarding the national defense. After a thorough study, beyond the fact that Romania benefits from a vast relief, its territory is situated, by geostrategic point of view, in a dynamic space, inside which there are sources of insecurity that had and are still generating military hostilities.

Furthermore to this is added the over technologizing in the military domain with has become an important worry beyond the possible enemies of NATO. Those ones had invested an enormous amount of money for maximizing the research for the purpose of modernization of classical systems and means of striking and also developing new and modern ones.

This new equipments that were developed are represented by nuclear ammunition, intelligent ammunition such as warhead fitted with infrared, proximity or magnetic fuses, unmanned combat aerial vehicle (UAV), combat recognition drones and autonomous or remote-controlled robots.

The nuclear ammunition is the most destructive weapon, to which nothing can withstand as long as it is in the epicenter of the explosion, not even the newest field fortification. If the nuclear ammunition would explode near the most performant field fortification, in this case we can talk about personnel protection being considerable extent.

Combat robots can be programed to execute independent missions like video search, photographing the entrances and exits, field fortifications, destroying small staff fortification, laser marking of underground fortifications, and last but not least exposing the masking of the field fortification.

Intelligent ammunitions are designed to identify targets, that are usually uncovered armored vehicles, trail and destroy them. By the self-steering system, intelligent ammunitions, can be laser wave ammunition, infrared ammunition or intelligent ammunition based on millimeter waves.

The unmanned aerial vehicles (UAV) and airborne early warning and control (AEW&C) system radar are systems designed to identify airplanes, crafts and vehicles at long ranges and also to conduct command and control(C2) by leading aircraft strikes. These kind of sistems are also used to conduct surveillance, including field targetting and perform strike command similar to an Air Traffic Controller.

The striking success of the opponent in the future integrated battlefieldcan also be attributed to the deficiencies within the general protection system, in which the field fortifications executed according to the present conception cannot fulfill their role in a timely and effective manner.

In other words, the development of performant systems and means of striking domain requires new progress in the general protection system, within which the field fortification must play an important role.

The present desire of armies General Staff for carring out the engineering support, underlines the necessity for mechanized endowment in order to carry out the works of field fortification in the shortest possible time and with the use of minimum resources but also the use of specific modular buildings and facilities for the Command Headquarter.

Romanian national program for NATO membership and the Implementation Plan for partnership objectives, elaborated in accordance with the Action Plan of the Romanian government program, the national security strategy and the military strategy include as an important component the need of interoperability and compatibility of Romanian Army's endowment with other NATO member equipment.

In order to fulfill the committed objectives, and successfully achieve Romanian Army's missions, it is requireda judicious thinking regarding the distribution of resources, by objectives goals, programs formajor endowment and new development strategies, all in correlation with each other.

In this regard, the activity in the spectrum of equipping the army must focus on the acquisition of equipment and systems that are important for supporting the extensive process of modernization, but also for those needed for the operationalization and support of the forces participating in the theaters of operations.

The acquisitions of modern military equipment and heavy machinery, is part of the national strategy, namely increasing the country's defense capacity and ensuring the interoperability of the military with the NATO and EU military structures.

In achieving interoperability, it is necessary to develop an intellection influenced by the essential requirements represented by the technological side. It is known in the past, that NATO and EU need strong members for having a stronger defense force. From an operational or technological perspective, interoperability is viewed by many countries that are NATO member as a level of standardization with mission types and operating environments, which allows for a systematic approach of military capabilities.

Military interoperability must be viewed and accomplished from several issues: defense policy, military provisions and regulations, command structures, linguistic and operating procedures, psychological education and training, practice and armament, existing or in the process of modernization equipment and technique, and so on.

Interoperability at all levels involves significant costs, even for NATO. Currently, through the major procurement programs and the technological transfer carried out in the national industry, the development of specialized technological capabilities is being tried to ensure a gradual interoperability.

Very important in achieving interoperability is also finding the balance between the use of old technology, which has proven its usefulness and which have been technologically validated by war practice, trying to modernize them, with significant costs for carrying out research and experiments, and the option for using future technology, which are not yet mature and involve higher costs in short and medium term.

Army engineering support has always been, in all armies, both within NATO and outside the Alliance, one of the main forms of support for military operations regardless of their nature. The basic role of engineering support is, regardless of doctrine, closely linked to the modeling of the field space in relation to the needs of maneuver forces, specific to the different types of operations and / or the different phases of operations. The conflicts of the last two decades have confirmed the importance of engineering support, as well as the need for the development of this branch to keep pace with the development of the other forces.

The role of the engineer forces in the operations of the Land Forces is the support of the own forces by the genial arrangement of the field in the operations area, so as to contribute to the accomplishment of the combined functions, respectively of the combat functions at the tactical level.

The operational environment in which the engineer structures operate is integrated into the one in which the Land Forces structures act. The basic mission of the engineer support for the Land Forces is manifested by providing specialized support in the following areas of operational assistance: mobility, counter mobility, maintaining the operational capacity and general engineering support.

In terms of ensuring forces mobility, enemy counter mobility and maintaining operational capacity for their own forces, as well as for achieving the engineering capabilities assumed by Romania for those structures from Land Forces that are used by NATO, it is necessary to equip the engineer structures with the necessary equipment, which have performant features.

The current endowment of the engineer forces in the armies of the NATO members and other modern armies for accomplishing engineering support missions, emphasis on the

mechanized equipment in order to accomplish them in the shortest possible time and using minimum resources.

At international level, the tendencies of weapon development are determined by three fundamental factors.

The first of these is the evolution of the specification of operational area environment reflected in the last two decades conflicts and, first of all, the specific threats in the new theaters of operations.

The second factor is developing response technologies for threat.

The third, but no less important, is the evolution of the internal and international normative framework regarding the protection of the environment and of human rights, including during military operations conducting.

Also, lately, the aim is to minimize the size of the engineering machines that are used to perform specific fortification works in order to be transported as quickly as possible in the areas of operations by air.

In order to maintain a correlation between the performant systems and means of striking and the component of the general protection system in the operations of the land forces, represented by field fortification we need to understand a simple physics principle of actions (-A) and reactions (+R), that in our case are represented by the ammunition (action) and the obstacle, field fortification (reaction). In fact it can be appreciated that when the projectile hits the obstacle, the action can be bigger, smaller or equal but opposite as the reaction. In this case the three state conditions are:

$$(-A) < (+R); \quad (-A) > (+R); \quad (-A) = (+R); \quad (1)$$

In our case, the first situation doesn't mind us, because the reaction is bigger than the action and so the projectile won't destroy the field fortification. In the second case it is obviously that the action is higher than the reaction, and the field fortification will not resist to the strike. The only state condition that worries us is the last one in which the action is equal with the reaction:  $(-A) = (+R)$ . (2)

In order to obtain this balance we have to calculate the depth of penetration of the projectile ( $h_p$ ). Taking into account that the action is represented by a projectile (-A) of mass "m" that under the action of a force of inertia penetrates to a certain depth ( $h_p$ ), the outcome will be:

$$-A = m \times h_p \text{ and } m = G/g, \text{ where:} \quad (3)$$

- "G" - the weight of the projectile (Kgf);
- "g" - gravitational acceleration ( $m/s^2$ );

Substituting the value of "m" in the above formula will result in the following equation:

$$-A = G/g \times h_p \quad (4)$$

Knowing that (+R) is the size of the projectile's resistance to advancing in the homogeneous or stratified environment of the obstacle and that the projectile has the cross-sectional area of the section ( $\pi d^2/4$ ) and that its penetration is equal or below 60 degrees angle the outcome will be:

$$R = 2( K \times S \times V + \cos \alpha), \text{ where:} \quad (5)$$

- K - cohesion coefficient of the particles in the composition of the environment;
- S = ( $\pi d^2/4$ ) - cross-sectional area of the section;
- V - the velocity of the projectile at impact;
- $\cos \alpha$  - the cosine of the angle between the projectile and the environment;

From the equations (4) and (5) the outcome will be:

$$G/g \times h_p = 2( K \times S \times V + \cos \alpha) \quad (6)$$

Performing the mathematical operations will result that the general formula for calculating the depth of penetration of the projectile is:

$$h_p = 2( K \times S \times V + \cos \alpha) \times g / G \quad (7)$$

To conclude by correctly calculating the depth of penetration of the projectile in the ceiling of a buried shelter we can determinate the following:

- the constructive dimensions of the structure resistance of the shelter;
- the constructive dimensions of the ceiling of the shelter;
- the magnitude of the effects of the blow on the shelter, and also on the personnel and the equipment or materials that are located in the shelter.

#### **BIBLIOGRAPHY**

MirceaVladu, Ioan Dan POPA, *Fortification, masking and water supply*. Sibiu: “Nicolae Bălcescu” Land Forces Academy, 2017.

Government of Romania, *Romanian White Paper on Defence*. Bucharest, 2017.

*Romanian Military Strategy*, 2016.

MirceaVladu, *New mathematical models for calculating the possibilities for implementing engineer support missions*. Bucharest: CTEA, 2007.

MirceaVladu, *Endowing the engineer forces according to the requirements of war of future*, Bucharest: “Carol I” National Defence University, 2006.

Vasile Paul, *Conflicts of 21<sup>st</sup> Century. Projections in strategic*. Bucharest: CTEA, 1999.

<https://awaacs.nato.int/>

<http://airforce-technology.com/projects/a50/>



# THE CURRENT STATE OF DECONTAMINATION WITH THE HELP OF BIODEGRADABLE SOLUTIONS AND INTERNATIONAL TRENDS

Ionela-Mihaela GOGAN

“Nicolae Bălcescu” Land Forces Academy, Sibiu

cepoiu.ionela@yahoo.com

Scientific coordinator: Prof.Eng. Dănuț-Eugeniu MOȘTEANU, PhD

**Abstract:** *The uncontrolled proliferation of CBRN weapons of mass destruction, which have an immeasurable destructive capacity, represents the greatest risk that humanity has been exposed to and a serious threat to civilization and life. The exponential growth of potentially dangerous chemical and biological agents, intended for applicability in both terrorist attacks as well as in military conflicts, is an ever increasing threat. The article summarizes the main ecological methods of decontamination used at national and international level. These biodegradable compositions and methods have been studied and applied by the NATO armies, and the promising results communicated by the French, American or German specialists require the attention of the Romanian specialists as well.*

**Keywords:** decontamination, biodegradable, trends, substances, solutions

## 1. Introduction

In a world that is in a continuous transformation, all the countries of the planet are facing new CBRN threats. The rapid reaction force fueled by the results of the research of military specialists acts to counteract a wider spectrum of such threats, created both by conventional methods - attacks by war agents but also by asymmetrical methods just as devastating. Within the measures to ensure the CBRN defense, decontamination plays an essential role, as it limits and reduces contamination, and, also the number of victims, damage volume, the duration and the costs necessary to remove the consequences of the attack, the continuation of military operations.

A major component of CBRN decontamination is *ecological decontamination*, a concept unanimously accepted by the armies of the world, because it is imperative that the decontamination processes and compositions are eco-friendly, do not affect the integrity of the surfaces they decontaminate, but at the same time to be at least comparable to the classical ones in terms of decontamination efficiency, productivity, consumption ratio, versatility of the application domain.

*Decontamination with the help of biodegradable substances* is a special topic, difficult to approach, because a compromise must be made between the effectiveness of a decontaminant on a broader spectrum of agents and its ability to be "eco-friendly" and towards the surfaces it treats. This is why this type of decontamination is considered a significant challenge, because the available decontaminants are often too harsh and can destroy the environment, being non-degradable over time.

From an ecological point of view, biodegradability must be measured by its effects on the environment. Eliminating harmful effects may require more than primary biodegradation

and possibly less than final biodegradation.

Most of the scenarios related to the current threats consider the combined use of toxic and biological chemical agents possible and hence the concern for the application of technologies that will ensure their simultaneous decontamination. There are some contradictory tendencies regarding the requirement imposed on a decontaminant, to be effective on the entire spectrum of agents. Thus, decontamination specialists consider that is very appropriate to make strictly specialized decontaminants for each type of contamination, a so-called complete family of effective, fast-acting decontaminants.

Decontamination operations and technologies must meet new requirements, respectively to the needs of rapid reaction for decontamination, increasing the efficiency of personal / individual decontamination, a fast and efficient self-decontamination, decontamination of interiors and sensitive materials, mass decontamination of personnel, decontamination of surfaces after CBRN events, environment protection, a more effective implementation of measures to prevent decontamination.

## **2. Characteristics of Decontamination Solutions**

The main requirements of the solutions for decontamination are: high efficiency in neutralizing toxic biological and chemical agents, minimal toxicity and aggression, minimum residual material volume, easy handling and storage, minimal environmental pollution.

The most used decontamination solutions worldwide are those that have active components, chlorogenic agents. Watery solutions and suspensions based on neutral or basic hypochlorites or chloramines have a number of disadvantages that limit their use in the military field:

- relatively low content in active chlorine;
- low stability at conservation;
- high corrosive effect on metallic surfaces;
- special storage conditions;
- difficult preparation and use;
- aspect modification of the treated surfaces;
- the need for additional operations to maintain the means with which they were used;
- limited applicability only in the military field.

Also, the basic substances have a number of drawbacks: they destroy clothing, soften the paint on the fighting technique, etc.

Based on these considerations, some of the decontamination substances and their compositions have been put out of use (for example: sodium hypochlorite, monochloramine B, dichloramine B, sulfuryl chloride, sodium sulfide), and the research was directed towards finding new substances, respectively decontamination solutions that would limit these shortcomings, that would protect the environment. For example, the trichloroisocyanuric acid solution is characterized by:

- it is remarkably effective against all types of chemical or biological agents (sufficient alkalinity for the decontamination of sarin-soman substances and a high content of active chlorine, sufficient for the neutralization of "V" type vesicant and neuroparalytic toxic substances);
- it is easy to obtain and use, having a high stability;
- it is less polluting and corrosive;
- it has a wide spectrum of applicability.

### 3. Worldwide Trends

Substances that favor the decontamination process play an important role in the contamination compositions. One of the global trends is the use of procedures using decontaminating emulsions, which is possible only through the use of surfactants and suitable solvents. The use of decontaminating emulsions greatly improves the logistics of the decontamination operations and the productivity of the process, while at the same time reduces the consumption of materials.

Another trend that is becoming more and more popular in decontamination is the use of high energy fluids. By applying high pressure pulsating jets, mass transfer is favored, by directly contacting the decontaminant with the toxic control agent. The high temperature and the speed of the jets used favors the phenomenon of removal of particles from the surface, to which are added also surface agents that influence the mass transfer.

In addition to improving the neutralizing substances of chemical and biological agents, the aim is to obtain the highest efficiency in decontamination also by paying special attention to the physical and mechanical processes that take place at this level, by using substances that influence these processes or a modulated technique, in which the decontamination processes have several phases, which leads to high efficiency. This leads to a combination of decontamination methods so that they are no longer standalone, but sometimes mechanical-physical-chemical.

In our country there have been many concerns for decontamination with the help of biodegradable substances. It was taken into consideration that future decontaminating products would ensure the simplification of the preparation and use technology, as well as of the logistics in the military operations (rapid preparation of the composition from accessible components, easily soluble in water and which involve packing, storage, transport and easy handling). One of the solutions obtained is the modern decontamination composition, which has a reduced impact on the environment and on the material it detoxifies, ensuring the decontamination of all types of military toxic agents.

#### 3.1. The New Scientific Challenges of Decontamination

The new scientific challenges of decontamination are:

- 1) Theoretical basis of the reactivity of the decontaminant in relation to:
  - the type of agent – chemical, biological, TIC (toxic industrial compound) and TIM (toxic industrial material);
  - the nature of the surfaces - interior, exterior, sensitive equipment;
  - combinations of agents on different types of materials.
- 2) The analytical and predictive development of the decontaminant/decontamination algorithms and models;
- 3) Establishing the methods of applying / dispersing the decontaminants, in order to maximize the efficiency of the decontamination process;
- 4) Development of specific alternative scientific processes/approaches having the following requirements:
  - to allow the generation of "in situ" decontaminants even in the tactical field;
  - to address in an original way, beyond expectations, the chemistry of solutions and adsorption phenomena of the solid phase, including approaches related to gaseous, kinetic or energetic reactants.
- 5) Development of decontaminants:
  - not be restricted by pH or by different reaction conditions;
  - to react quickly with the whole spectrum of agents;
  - be safe and non-corrosive;
  - be renewable / catalytic, easily and evenly dispersible;

- to have high efficiency in small quantities over the entire spectrum of agents;
- be non-toxic or less toxic than current decontaminants;
- be environmentally safe, requiring minimal or no restoration for cleaning;
- to require minimal protection or lack of protection of the operating personnel.

The field of potentially decontaminated objects creates an enormous challenge for the efficient and rapid application of decontamination technologies and associated procedures.

There is an eloquent list of criteria for the evaluation of decontaminants, respectively of associated decontamination technologies, as follows:

- Efficiency against all CBRN materials;
- Efficiency under any environmental conditions;
- Speed of action;
- Ease of application;
- Reduced toxicity, including for detoxification products;
- Limited corrosive effect;
- Reduced mental stress for users;
- High stability in storage;
- Availability;
- Logistics support.

These criteria are successfully met by conventional decontaminants, with the exception of those regarding toxicity, corrosive effect, logistics support, essential for ecological decontamination.

Regardless of concerted efforts to eliminate the effects of using CBRN materials, these criteria must be followed and met especially in the most difficult cases.

### **3.2. Existing Biodegradable Solutions at International Level**

The main biodegradable solutions at International level for chemical and biological decontamination are:

*The MDF-200 decontamination foam*, developed by Sandia Laboratories, is a product designed for the rapid and efficient decontamination of chemical and biological agents, without generating toxic decomposition products. The MDF-200 applies to a consumption ratio of 1-2 l/m<sup>2</sup>. Evaluation of the decontamination efficacy on live agents, demonstrated the detoxifying effectiveness in 15 minutes on military toxic compounds (CCIM) and in one hour on anthrax spores. It has efficacy on some toxic industrial substances in maximum 30 minutes.

*GDS 2000*, a product of Kräker, is a non-watery, biodegradable, universal detoxifier for all types of toxic chemical agents (including the thick ones), with efficacy comparable to emulsions (Munster; TDE 202) and DS-2, but is much more eco-friendly and also friendly to the surfaces they decontaminate. Another advantage is the reduced consumption ratio. Thus, for the decontamination of a tank is required 12-24 l of GDS 2000, made in 5-10 minutes, compared with 200-600 l of emulsion made in 10-30 minutes.

*CASCAD*, a universal decontaminant for chem-bio decontamination, made by Vanguard is a foaming watery composition with 3D properties, practically coating the objects, adhering to the vertical surfaces. The product, a mixture of surfactant, decontaminant and co-solvent, ensures the decontamination of all types of chemical agents within minutes and biological agents within maximum 30 minutes.

*Bx-24*, is a Cristanini decontamination product. It is a chloride-based powder decontaminant, initially used for decontamination of vehicles and structures. The chemical and biological detoxification and decontamination product of the technique and various materials is applied in the form of a foamy suspension with different decontamination means,

of which Sanijet Gun C.921, the heart of the decontamination system, device with which the decontamination process is applied in three phases: high pressure washing; decontamination execution (BX-24); rinse under high pressure.

#### **4. Conclusions**

The key to successful decontamination is the use of the fastest approach, with minimal material and especially human damage. Response measures are concentrated and prioritized for saving lives, protecting health, followed necessarily by limiting the spread of contamination, and also protecting the environment.

In such events, rapid response teams should use any available resources as quickly as possible and select the fastest methods available, as the most effective decontamination is when it is done immediately.

The ecological solutions respond to a revolutionary concept of decontamination that have a small impact on the surfaces they decontaminate and on the environment, because it ensures the neutralization of toxic and biological agents with military specificity at moderate pH and they have reduced aggression compared to the chlorogenic or organic compositions.

The following conclusions were highlighted from the exposed fundamental concepts, as well as from the test results:

- There are some contradictory tendencies regarding the requirement imposed on a decontaminant, to be effective on the whole spectrum of agents;
- On a global level, the concept of ecological decontamination has become a very popular one, used in scientific research, and approached by most of the armies;
- Although new decontamination processes and solutions need to be less aggressive with the environment and not to affect the surfaces they decontaminate, it must be taken into account that these methods must be at least as effective as the classical ones;
- The main requirements of the solutions for decontamination are: high efficiency in neutralizing toxic biological and chemical agents, minimal toxicity and aggressiveness, a minimum volume of residual material, easy handling and storage, minimal pollution of the environment;
- In the Romanian Army, decontamination with the help of biodegradable solutions is still in the research, design and testing stage, but considerable efforts are being made to promote ecological decontamination;
- Although it is an ecological and polyvalent decontaminant, because it has decontaminant efficiency at pH 9 on the whole spectrum of chemical warfare agents, pesticides, as well as biological agents, the peroxide composition has not been put in use because it can only be utilized with plastic decontamination means;
- The production of chemical and biological decontamination equipment with H<sub>2</sub>O<sub>2</sub>, will lead to its use on a large scale also in the Romanian military field.

#### **BIBLIOGRAPHY**

- Spencer R.C., Wilcox M.H. *Agents of biological warfare*. Rev Med Microbiol, nr.4, 1993.
- Păun, Ludovic. *Bioterrorism and biological weapons*, Amaltea Publishing House, 2003.
- Nicoleta Grigoriu, Georgiana Ciofrîngeanu, Gabriel Epure, Georgeta Mitru, Panaghia Deliu *Nomenclature of chemical and biological agents*, București, 2010.
- Ion Savu, Dănuț Mosteanu. *Basics of radioactive, chemical and biological decontamination, Volume I*. "Nicolae Balcescu" Land Forces Academy Publishing House, Sibiu, 2010.

I. Savu, G. Ciofrîngeanu. *Present and perspectives in chemical decontamination*. Military Technical Publishing House, no.1, 2008.

Lydia-Maria Vaicum. *Biodegradability of detergents*. Academy of the Socialist Republic of Romania Publishing House, 1971.

*NBC Defense Magazine*, no.4 (2/2002).

*NBC Defense Magazine*, Year IV no.1 (9).

[www.ecbc.army.mil/ps/download](http://www.ecbc.army.mil/ps/download).

William Bell, Brian France, Trudy Scholten, Allen Willey, James Tinlin, James Roston, Brent Mason, Larry Procell, *Electrochemically generated liquid decon solution*, 4<sup>th</sup> International Symposium on NBC-Decontamination Munster, October 2006, Germany.

Stef Stienstra, *The use of singlet oxygen to inactivate both chemical and biological weapons*, The sixth Plenary SPIEZ LABORATORY, CBMTS VI, Spiez, Switzerland, 2006.

Alexander M., *Biodegradation and Bioremediation*, Academic Press, San Diego New York Boston London Tokyo Toronto, 1994.

Pavel Častulic, *Quo vadis decontamination?*, 3<sup>rd</sup> International Symposium on NBC-Decontamination Munster, September 2004, Germany.

# DESIGN AND OPTIMIZATION OF A FLYWHEEL ENERGY STORAGE SYSTEM

Ionuț-Narcis GRINDEANU  
“Nicolae Bălcescu” Land Forces Academy, Sibiu  
ionut.grindeanu@gmail.com  
Scientific coordinator: Eng. Radu PETRUSE, PhD

**Abstract:** *The objective of this research paper is to develop, design and optimize a Flywheel Energy Storage (FES) system using the Finite Element Analysis (FEA). The starting point is describing the system and presenting its evolution and domains of application. Furthermore, we study the FES latest version, by checking scientific databases and experiments, with the main goal of identifying the key elements. Then we use FEA with the aim to optimize the elements by obtaining the ideal combination of lowest weight of the piece and maximum value of applied forces. In the virtual simulation process, we use different materials, sizes and forces in order to create several configurations that we will compare afterwards. In conclusion we establish if the FES optimization goal was achieved and which was the best parameters configuration that we found by using FEA.*

**Keywords:** flywheel, energy storage system, finite element analysis.

## 1. Introduction

Flywheel Energy Storage System (FESS) has the utilization of a mechanical battery and it's exploited in storing the mechanical energy and in transferring it to and from the flywheel, using a motor or a generator.

## 2. Background

FESS has its origins in the Middle Ages, one of the earliest examples being the potter's wheel, which was used to maintain its energy under its own inertia. These spinning wheels had applicability in water wheels, lathes, hand mills and other rotary objects powered by both humans and animals and they evolved in the 18th century by having the wooden construction replaced by a single massive iron piece. Industrial Revolution was the moment when the term flywheel firstly appeared. With a greater moment of inertia, these heavy flywheels converted the long forceful reciprocating stroke of a steam engine into smooth usable rotational energy, leading to migration of steam engines to internal combustion engine. From the first three-wheeled vehicle, built by Karl Benz in 1885, all internal combustion engines require some form of flywheel to operate. Rotor shapes and rotational stresses had major developments in the early 20<sup>th</sup> century, when the flywheel started to be considered as a potential energy storage system.

### 3. Operating principle

FESS typically use electricity as the working energy the input energy to a flywheel energy storage system is drawn from an external electrical energy source, such as a power grid. The flywheel speeds up as it stores energy and slows down when it's discharging to deliver the accumulated energy. The rotating flywheel is coupled to an electrical motor – generator unit that performs the interchange of electrical energy to mechanical energy and vice versa.

The energy storage capacity of a flywheel is primarily determined by its shape and material. Known as the flywheel rotor in most flywheel energy storage systems its capacity is linearly proportional to the moment of inertia or the resistance to angular acceleration and the square of its angular velocity ( $E = \frac{1}{2}I\omega^2$ ). In effect increasing the rotating mass optimizing the shape or increasing rotational speed of the rotor allows it to store more energy. In practice, these three properties are constrained by several design factors, the usable rotational speed range of the system is capped by the voltage variation limits of the motor generator system. If the rotor speed drops below a minimum limit it will produce too low of voltage when discharging the flywheel rotor, while spinning it too quickly during charging can exceed that limits of the motor – generator. These limitations of the motor – generator systems itself always result in a region of inaccessible storage energy capacity within a flywheel energy storage system. The output power and electrical efficiency of flywheel energy storage systems is implicitly also limited by that of the motor – generator. Permanent magnet synchronous motors tend to be the most commonly used electrical machines on flywheel energy storage systems, because of their 95.5% efficiency high power density and low intrinsic losses. Beyond the motor generator limits the maximum speed limit at which the flywheel rotor can operate is also determined by the tensile strength of the material from which is made. As the rotor revolutions per minute (rpm) increases and hoop stresses within the rotor exceed the tensile strength limits of the material, the rotor will begin to break apart. The cast iron flywheel is used on early steam engines were far too weak for high rpm use. Better performing alloys made of titanium, magnesium, aluminum and steel were developed offering up to 20 times more tensile strength. Composites such as glass fiber and carbon fiber reinforced polymers, pushed flywheel tensile strength even further, easily doubling the capabilities of high-performance metals toughness at greater cost. Because the shape of a flywheel rotor affects its moment of inertia and inherently it's energy storage capacity, how efficiently the mass of the material used is utilized is determined by the shape factor of its geometry. Cylinder based geometries tend to have lower shape factors depending on their wall thicknesses while solid disks utilize more of the material mass. Novel disc shaped rotor geometries approach near perfect shape factors, but are limited to low rpm metal construction. In practice choosing a flywheel shape and material is determined by its application. Requiring a balancing act between the specific energy or energy per mass and energy density or energy per volume of the flywheel. Automotive applications for example might favor energy density as a goal due to packaging requirements. While grid storage systems may focus more on the specific energy. Flywheel storage system designs generally fall under one of two strategies low speed flywheel systems that operate under 10000 rpm and high-speed variants that can approach 100000 rpm. Low-speed flywheels are usually made of heavier metallic materials and are supported by either mechanical or even non-contact magnetic bearings that support the load with magnetic levitation. High-speed fly wheels typically use lighter, stronger composite materials and require magnetic bearings. Because flywheel energy storage systems usually enclose the flywheel within a vacuum to reduce friction, the primary point of energy loss happens at the bearings that support the flywheel. Not only must the bearing support the flywheel but also resists the forces resulting from its changing orientation, especially the persistent rotation of the earth. These changes are resisted by the gyroscopic forces exerted by



the flywheels angular momentum, which express a forces against the bearing system. Traditional mechanical bearings used on low-speed flywheel energy storage systems suffer from high maintenance requirements and a dependence on high-performance lubricants to function. They're particularly sensitive to gyroscopic forces and the friction it generatesmechanicalbearing lose about 5% of a flywheel total storage capacity per hour. Magnetic bearings in comparison have no friction losses and don't require any lubrication but may require power to energize them in some configurations. Magnetic bearings come in permanent magnet, active magnet and superconducting magnet variations. Magnetic bearing systems are capable of reducing parasitic losses down to about 1% of flywheels total storage capacity per hour.

**4. Structure and components of FESS**

Figure 1 represents a typical flywheel system suitable for ground-based power :

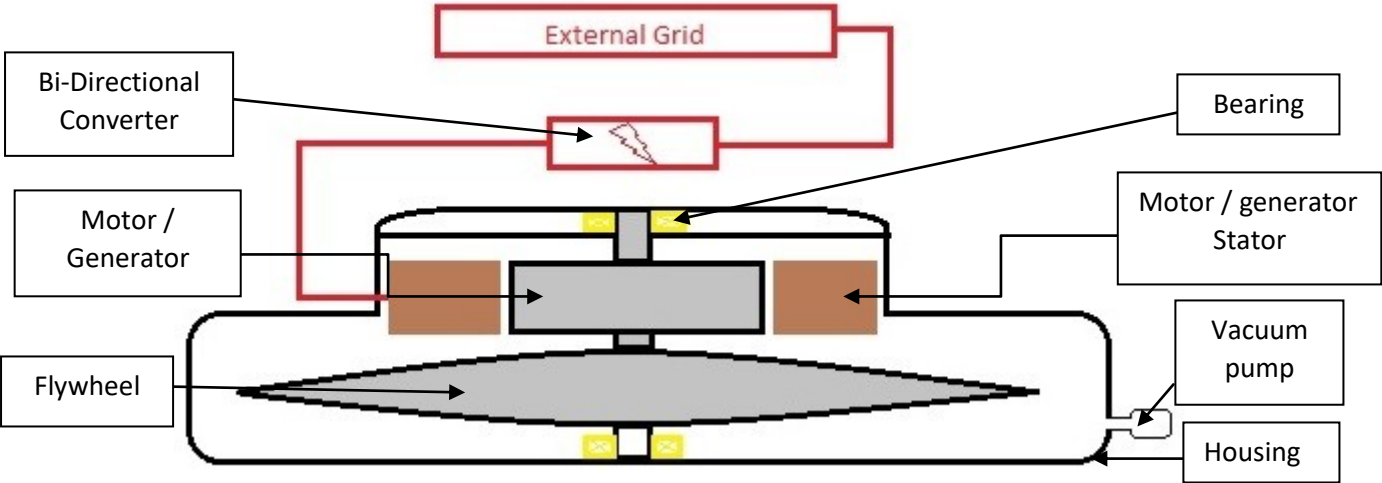

Figure 1: Structure and components of a flywheel

**5. Domains of applications of flywheel energy storage system**

FESS is used in different domains, having the most common applications in: *power quality such as frequency and voltage regulation* (the fast response makes flywheels an ideal resource to provide regulation services thus freeing up thermal generators to service the energy market and operate at higher output levels, improving fuel efficiency and reducing emission rate); *pulsed power applications for various purposes*; *military applications* (in Electromagnetic Aircraft Launch System); *civil applications* (for example in propelling the trains of a rollercoaster); *transportation*(kinetic energy recovery systems is used in cars of Formula 1 and hybrid vehicles); *spacecraft* (implemented in space vehicles where the primary source of energy is the sun, and where the energy needs to be stored for the periods when the satellite is in darkness).

**6. Methodology**

The main components of a FESS are: the bearing system (can be magnetic, mechanical or combination of the two); the motor / generation (electrical machine) - most used are permanent-magnet synchronous machines; the flywheel - identified as the key element for this research.

The parameters of a flywheel that have a significant influence on the systems performance are: material: higher strength materials can be used at high rotational speeds permitting the storage of more energy; geometry : has the role of controlling the kinetic energy storage capability of the flywheel; rotational speed: the stored energy is related to the square of the rotational speed and increasing it is the best method of increasing the energy

stored in the flywheel. All three elements are linked due to the fact that the maximum speed must be directly correlated with the maximum tensile strength of the flywheel material and with the outer diameter of the flywheel.

Using the Finite Element Analysis (FEA) methodology we worked on the design and assessment of the flywheel component, targeting to obtain the results of Mass and Maximum Angular Velocity values needed to calculate the Mass Moment of Inertia and the Maximum Kinetic Energy values.

Mass moment of Inertia (ability of an object to resist changes in its rotational velocity):

$$I = k m r^2 \quad (1)$$

Where  $k$  = inertial constant - depending on the shape of the body ,  $m$  = mass,  $r$  = radius

Laval disk (Constant Stress Disk)



$K = 1$

Rim with web (typical)



$K = 0,5$

Maximum Kinetic Energy:

$$E = \frac{1}{2} I \omega^2 \quad (2)$$

Where  $I$  = mass moment of inertia,  $\omega$  = rotational velocity

We have chosen to analyze 3 shapes of flywheel: disk, perforated disk and rim with web. The materials considered for the computation of flywheel energy are: Aluminium, Steel and Titanium.

The material properties are shown in the table below:

Material	a. Aluminium	b. Steel	c. Titanium
Young's Modulus [N/m <sup>2</sup> ]	7e+010	2e+011	1,14e+011
Poisson's Ratio,	0,346	0,266	0,34
Density [kg/m <sup>3</sup> ]	2710	7860	4460
Yield Strength [N/m <sup>2</sup> ]	9,5e+007	2,5e+008	8,25e+008

Material Properties (Table 1)

The shapes and dimensions are shown in the table below:

Dimensions	1. Disk	2. Perforated disk	3. Rim with web
Outer Diameter [mm]	400	400	400
Inner Diameter [mm]	30	30	20
Rim Height [mm]	-	-	40
Rim Width [mm]	-	-	20
Thickness [mm]	41,5	41,5	41,5

Shapes and dimensions (Table 2)

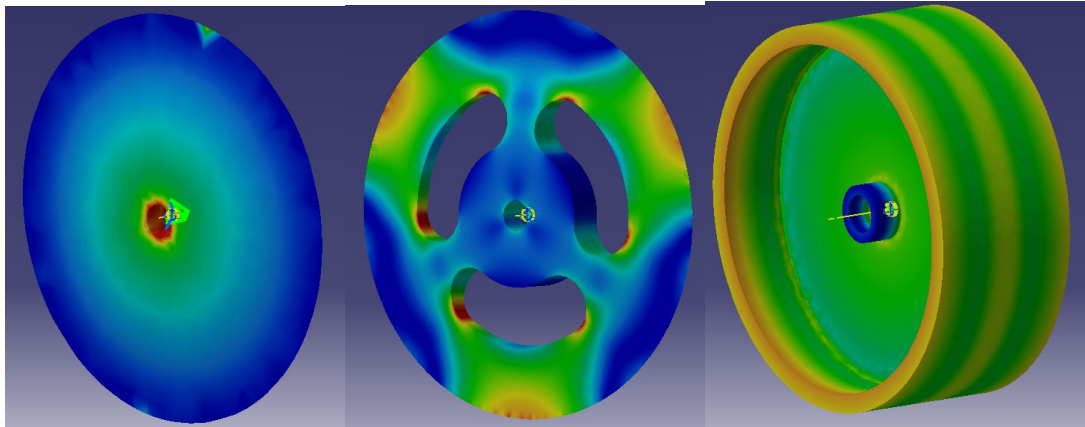

Figure 2: Models of flywheel

**Table no. 3**  
Experimental Results

Shape	Material	Results obtained from Catia (FEA)		Results calculated based on FEA values	
		Mass [kg]	Maximum Angular Velocity [rad/s]	Mass Moment of Inertia [Kg*m <sup>2</sup> ]	Maximum Kinetic Energy [Nm]
1. Disk	a. Aluminium	5,517	1564	0,1241	151820
1. Disk	b. Steel	16,001	1499	0,3600	404485
1. Disk	c. Titanium	9,079	3595	0,2043	1320044
2. Perforated disk	a. Aluminium	3,344	980	0,0752	36130
2. Perforated disk	b. Steel	9,698	935	0,2182	95380
2. Perforated disk	c. Titanium	5,503	2253	0,1238	314249
3. Rim with web	a. Aluminium	7,662	1000	0,0862	43099
3. Rim with web	b. Steel	22,224	946	0,2500	111873
3. Rim with web	c. Titanium	12,61	2296	0,1419	373922

## 7. Results and Conclusions

The experimental simulations aimed to obtain the Maximum Kinetic Energy (MKE) values (shown in Table 3) so we can analyse and compare them, taking into consideration the used shape and materials.

A very important factor in determination of MKE is the K factor (inertial constant), which is strictly based on the shape of the flywheel and we can state from the beginning that K factor of Laval disk (K=1) is double than the one of rim with web (K=0,5), expecting to have better results of MKE for the first shape.

Comparing the results by shape we can observe that disk shape has the best performance (highest value of MKE), rim with web comes next and least performance is the one of perforated disk. If we analyse the outcome by type of material it is clearly that Titanium is the best one, having the highest value of MKE for each shape. If we look at the results overall we can say that model 1a (Titanium Disk) has the optimum configuration, having MKE value the greatest: 1320044.

From the analysis of the created configurations it is observed that the greatest influence on the specific energy accumulated by the flywheel have the shape of the flywheel; follows material, including the K factor.

Powerful tools of Catia allowed us to conduct a design study that provide valuable information for the analysis and optimization of the flywheel.

Recent flywheel designs are based on analytical structures derived from simulation results. Analysis and simulation of flywheel behavior is a relatively new concept to the modeling done on flywheels. This can be of great assistance to specify the energy storage capacitance of the designed flywheel before actually developing one and thus can cut the cost expenditure if any faults are set up and can correct them.

### **BIBLIOGRAPHY**

Aakash Rajan, Parth Patel and Dr. Tushar Patel. *FEA and Optimization of Flywheel Energy Storage System*. Gandhinagar: IOSR Journal of Mechanical and Civil Engineering (IOSR-JMCE), 2017.

Ankita Shinde, Kratika Singh Rawat, Ruchi Mahajan, Veeraj Pardeshi, Balbheem Kamanna and Sheravi. *Design and Analysis of Flywheel for Different Geometries and Materials*. Mumbai: Mumbai University, 2017.

Emad, Basmaji. *Flywheel Energy Storage System*. Deggendorf: Institute of Technology, 2018.

Ionel Chiriță, Cristinel Ioan Ilie, Nicolae Tănase and Marian Popa. *Design optimization of a flywheel using solidworks modeling and simulation capabilities*. Bucharest: National Institute for Research and Development in Electrical Engineering ICPE-CA, 2017.

Mustafa Amiryar and Keith Pullen. *A Review of Flywheel Energy Storage System Technologies and Their Applications*. London: University of London, 2017.

# A MODERN AUTOMOTIVE MAINTENANCE

Cornel-Iulian HARPĂU

“Nicolae Bălcescu” Land Forces Academy, Sibiu, Romania,  
harpau.cornel@yahoo.com

Scientific coordinator: COL Assoc.Prof.Eng. Ioan VIRCA, PhD

**Abstract:** *The following article addresses a topic known throughout the world. It refers to the automotive industry and the ways in which vehicles can benefit from proper maintenance in a timely manner. To study the problem will be addressed theoretical notions about car maintenance, but also ways to implement a software solution to make maintenance easier. In order to determine the advantages of a software, a comparison between the old methods and the new methods of doing a proper maintenance will be presented. In conclusion, the topic addressed will provide a software solution meant to improve the car maintenance system.*

**Keywords:** automotive maintenance, software solution.

## 1. Introduction

Maintenance, as a theoretical notion, first appeared in the world industry in 1950, and this term spread rapidly and replaced the terms of keeping and repairs. The reason for renouncing the term "keeping" marks an evolution of the concept.

The service sector has become very significant, particularly in the developed world economies. At the end of the 20th century over 60% employees were engaged in the service sector in the most developed market economies. This percentage is even higher nowadays, naturally in favor of service industry.

The dynamics of the society required the development of the industrial activity of vehicle construction and determined a higher production that present high quality and all that are realised with the lowest costs.

## 2. Theoretical notions

Maintenance can be defined as the set of technical and organizational actions, associated and performed on machines and existing equipment in an enterprise for the purpose of keeping them at a specific parameters.

As a technical meaning, term of “maintenance” involves some functional checks, servicing and repairing of a specific machinery. Also, activity of maintenance involves replacing of broken devices and affected equipment. In last years, this has included several formulations that describe some cost-effective practices for maintaining a functional equipment.

Maintenance activity is complex and can be structured into three categories:

- *Corrective maintenance:* based on good operation until the system crashes;
- *Preventive maintenance:* time-based maintenance;
- *Predictive maintenance:* it is based on the condition of the machine.

## 2.1. Corrective maintenance

Corrective maintenance has a simple operating principle: every time a machinery or any system fails, the following operation is repairing or restoring of broken device. The following steps describe corrective maintenance:

- If the failure is detected, it has to be confirmed firstly. If the failure isn't confirmed, affected device is returned to service. The previous steps represent a waste of time and money.
- If the failure of system or broken device is confirmed, the item will be prepared for a good maintenance.
- The next step is to isolate the broken part in the system.
- The broken part is repaired. If that item can't be repaired, a new part will be installed in its place.
- The broken item will be adjusted after repair. It will be checked before and after being put back to system.

All that steps are resumated in the following figure (Figure1):

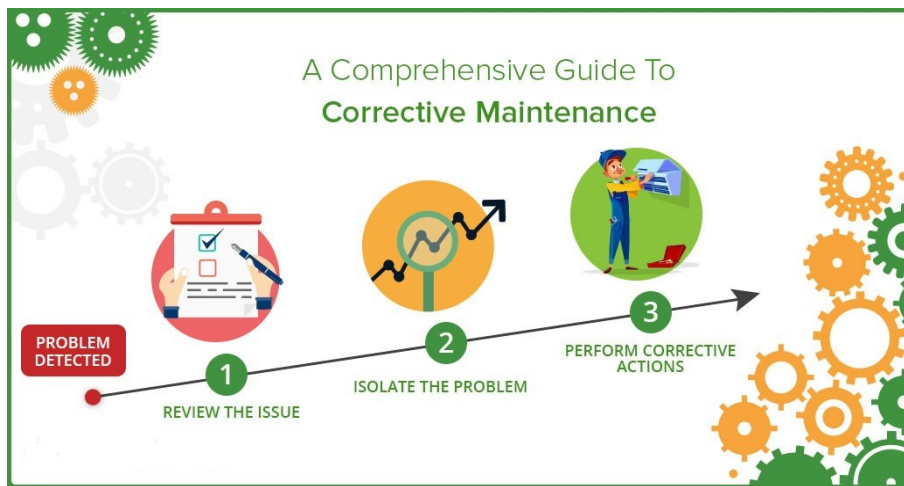

Figure1. Corrective maintenance steps

## 2.2. Preventive maintenance

It is also called prophylactic maintenance and consists of a series of activities undertaken in order to maintain the vehicle or its component systems, under normal operating conditions, being practically achieved by systematically replacing the elements and carrying out works, maintenance, repairs, adjustments, planned at certain intervals of time or kilometers traveled.

This type of activity can be divided into three categories:

- Systematic maintenance (preventive-planned): it is materialized by maintenance, repair and overhaul, constituted in a standardized intervention plan, specific to each individual vehicle.
- Predictive maintenance: it is subordinated to the analysis of evolution followed by the significant degradation parameters of the vehicle, allowing the delay and planning of the interventions.
- Conditional maintenance: involves tracking the parameters for the wear of subassemblies of vehicles, with the help of specific instruments, following as maintenance interventions should be done before the defect status appears.

### 2.3. Predictive maintenance

Predictive maintenance and its techniques are used to determine the condition of the equipment in operation and to estimate the time when maintenance should be performed. This approach comes with promises of cost savings for routine or time-based preventive maintenance, as tasks are realised only when warranted. Thus, it is considered a condition-based maintenance, as suggested by the estimates of the degradation status of an equipment.

The main target of predictive maintenance is to implement a convenient scheduling of the first maintenance, corrective one, and to prevent or eliminate unexpected equipment malfunctions.

Predictive maintenance is different in comparison with preventive maintenance because it is based on the actual condition of the machinery, rather than life statistics that are expected, to predict if maintenance will be needed.

### 3. Software solution

Keep the Machine Running (KMR) is a modern system for maintenance management, intended for planning and organizing the flow of maintenance activities for: machines, equipment, companies or office buildings.

Its main role is to efficiently organize the entire maintenance activity and to provide to the responsible personnel control over the equipment, materials, activities and costs associated with the maintenance.

KMR integrates IoT (Internet of Things) technologies focusing on automatically gathering information about equipment and other useful parameters for maintenance management:

- Temperature;
- Concentration;
- Vibrations;
- Pressure;
- Level.

KMR is easy to use/access (laptop, tablet or smartphone) and provide a friendly interface (Figure2) which show an overview of maintenance activity, as well as specific information for each implemented action.



Figure2. KMR Interface

### 3.1. Advantages of a software

The software facilitated the transition from pen and paper to the digitization of maintenance activities that allowed the monitoring of real-time work interventions, the rapid generation of accurate reports, as well as the identification, planning and monitoring of preventive, predictive and corrective maintenance. The main advantages of using a maintenance software are:

- Maximizing equipment availability and minimizing maintenance failures before problems arise;
- Reduce downtime and repair costs;
- Reduce overtime by decreasing the need for any emergency maintenance and repairs of a device;
- Increase safety of staff and of equipment by using safety standards to prevent malfunction or critical failures;
- Eliminate the need for clipboards or paperwork because the software can be programmed to capture essential information automatically;
- Manage the orders efficiently;
- Manage the spare parts inventory.

### 4. Conclusion

The maintenance term is a new one in the auto industry, appearing in 1950, but it has enjoyed great success worldwide, and has the purpose to keep machines and existing equipment at a specific parameters.

It is clear that car maintenance has evolved over time, and this has been achieved due to the software solutions implemented in the near past. A maintenance software helps the user to reduce his work performed, and the control over the machines is easily achieved in a short time.

The main benefit of KMR software is that it helps user to efficiently organize the entire maintenance activity and it provides a friendly interface which show a specific information for each implemented action.

### BIBLIOGRAPHY

- Andreescu, C. – Fiabilitatea și mentenanța autovehiculelor, Curs Universitatea Politehnică din București, 2007.
- Băjescu, T. – Fiabilitatea sistemelor tehnice, Editura MatrixRom, București, 2003.
- Cordoș, N., Filip, N., *Fiabilitatea autovehiculelor*, Editura Todesco, Cluj-Napoca, 2000.
- Verzea, I., Gabriel, M., Richet, D. – Managementul activității de mentenanță, Editura Polirom, București, 1999.
- Panaite, V., Gh. Munteanu, I. R. – Control statistic și fiabilitate, Editura MatrixRom, București, 2003.



# COMMUNICATION CHANNELS MODELS IN SIMULINK ENVIRONMENT

Mihai-Viorel JOIȚA

“Nicolae Bălcescu” Land Forces Academy, Sibiu

joitamihai30@gmail.com

Scientific coordinator: Assist.Prof. Emil TEODORU, PhD

**Abstract:** *The purpose of this research is to study parameters and the behavior of different modulations. In order to realize this scientific research I used MATLAB/SIMULINK. Attention was particularly focused on study of the performances of the BPSK, QPSK, PSK, DPSK and QAM modulations. The signal source, type of modulations, channel noise are some aspects which influence will be illustrated in this study. In each created model the results arise by modifying sources and channels parameters.*

**Keywords:** communication channels, signal, channel noise, channel parameters, modulation.

## **The performances of the digital modulations in MATLAB**

Simulink is a program specially designed to analyze, create and study dynamic systems. Within this program you can analyze both linear and nonlinear systems, which are modeled in continuous or discrete time or a combination of the two. Within the systems there may be sampled portions with different sampling frequencies.

In order to be able to understand a schematic of a communications channel, I have created a program that denotes the performance of several types of modulations, depending on the BER (Bit Error Rate) and the signal-to-noise ratio.

BPSK is the binary phase shift modulation that is performed bit by bit, each symbol being made up of a single bit. Depending on the value of the transmitted data bit, the phase of the modulated radio frequency signal performs phase jumps. In the case of BPSK, the two possible phase states (phase jumps) are  $0^0$ , respectively  $180^0$ , one of them being associated with a binary value 0, respectively 1. QPSK is the modulation with phase quadrature displacement, its peculiarity being that it transmits two bits per symbol, in other words the symbols do not represent 0 and 1, but 00, 01, 10 or 11.

PSK phase shift keying is a phase modulation that involves changing the phase of a carrier signal, at the beginning of each symbol period, with a value that depends on the combination of data bits (multibit) to be transmitted. The 8-PSK, 16-PSK, 32-PSK modulations are obtained from the set of phasors resulting from the PSK modulation of all possible multi-bit "p" bits, where "p" takes the values 8, 16, and 32, respectively.

DPSK is phase shift differential modulation and is commonly encountered in phase modulations because it transmits data by changing the carrier phase. For example, in the case of BPSK bit "1" can be transmitted by adding  $180^0$  to the initial phase, respectively bit "0"

adding 00 to the initial phase. In the case of QPSK, the phase changes are  $0^{\circ}$ ,  $90^{\circ}$ ,  $180^{\circ}$ ,  $-90^{\circ}$ , corresponding to bits 00, 01, 10 and 11.

QAM is the amplitude-in-quadrature modulation and has been imposed as a method of implementing the modulation of the demodulation of other types of amplitude, frequency or phase modulations, and like the PSK modulation, it comes with 4-QAM, 16-QAM and 32-QAM.

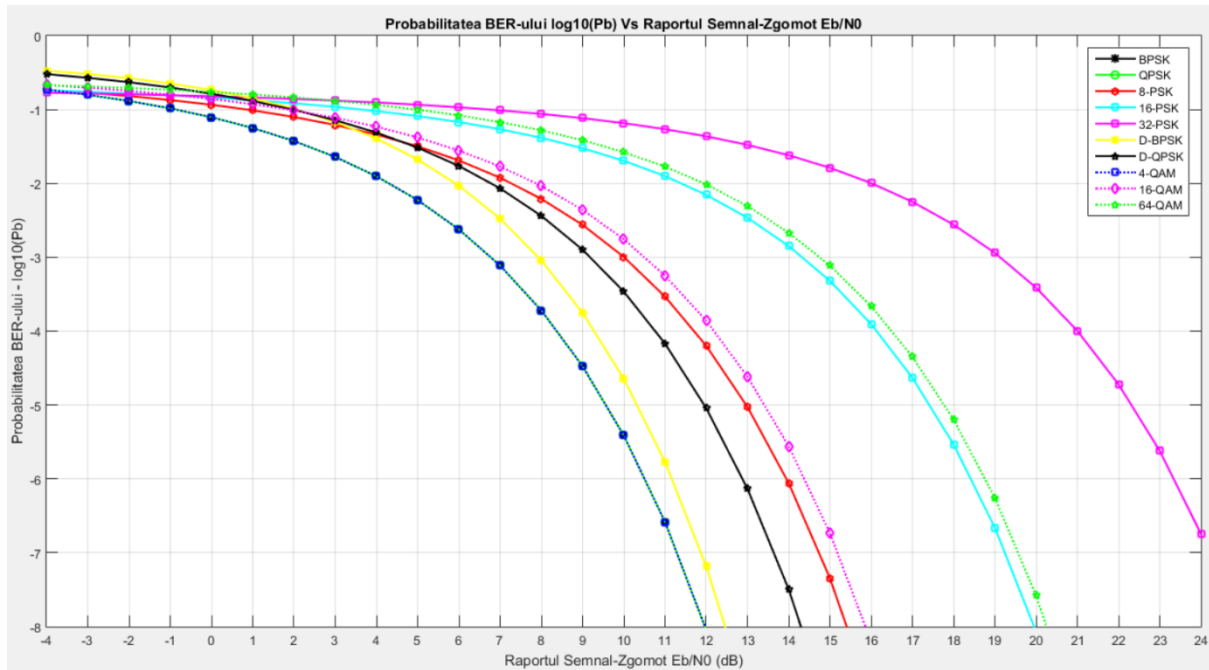

Figure 1: BER probability  $\log_{10}(P_b)$  vs Signal to noise ratio  $E_b/N_0$

## Conclusions

Table 1

Mod Vs SNR	BPSK	QPSK	8-PSK	16-PSK	32-PSK	D-BPSK	D-QPSK	4-QAM	16-QAM	64-QAM
9dB	-2.89	-4.47	-2.5	-1.5	-0.9	-3.75	-2.89	-4.47	-2.53	-1.41
7dB	-2.06	-3.11	-1.9	-1.2	-1	-2.47	-2.06	-3.11	-1.77	-1.71
4dB	-1.23	-1.9	-1.3	-1	-1.1	-1.39	-1.3	-1.9	-1.2	-0.93

- It can be observed that the QPSK and 4-QAM modulations have the same performance.

- The probability of the BER decreases as the order of magnitude of the signal is greater than that of the noise.

- At the 9dB level of the SNR the best modulations are QPSK and 4-QAM, and the weakest are 16-PSK, 32-PSK and 64-QAM.

- At the 7dB level of the SNR, the best modulations are also QPSK and 4-QAM, and the weakest 16-PSK, 32-PSK and 64-QAM.

- At the 4dB level of the SNR the weakest modulations are 64-QAM, 16-QAM and 16-PSK.

- Overall, following these calculations, the best modulations in terms of error bit rate are QPSK and 4-QAM, the weakest overall being 32-PSK.

- Other modulations with the parameters within acceptable limits of the users were the BPSK and D-BPSK, with relatively close values.
- If the signal is extremely weak, the noise having four units of measure over, the best modulation is 16-QAM, and the lowest D-BPSK.
- If the signal is approximately equal to the noise, the most appropriate modulation we can choose is QPSK, and the one that is not recommended to use is 64-QAM.

### Simulation of BPSK modulation in AWGN and Rayleigh channels

I simulated the generation of random variables  $r_0$  and  $r_1$  which constitute the input variables of the detector. At the beginning we generated zero and one binary sequences that appear with the same probability and are mutually independent from a statistical point of view. For this, we used a random number generator that generates a random number between 0 and 1. If the generated number is in the range (0, 0,5), at the output we will have the value 0, otherwise we will have 1. If it is generated at output 0, then  $r_0 = E + n_0$  and  $r_1 = n_1$ . If we generated a 1 at the output,  $r_0 = n_0$  și  $r_1 = E + n_1$ .

The additive noise components  $n_0$  and  $n_1$  are obtained from the average of two Gaussian noise generators, resulting in zeros or variations  $\sigma = \frac{E \cdot N_0}{2}$ . To simplify calculations, we will consider  $E = 1$  (the normed value) and we will vary the variable "o". The signal-to-noise ratio ( $E / N_0$ ) will therefore be equal to  $\frac{1}{2} \sigma$ . The output of the detector will be compared with the transmitted binary sequence, using an error counter variable to count the erroneous bits.

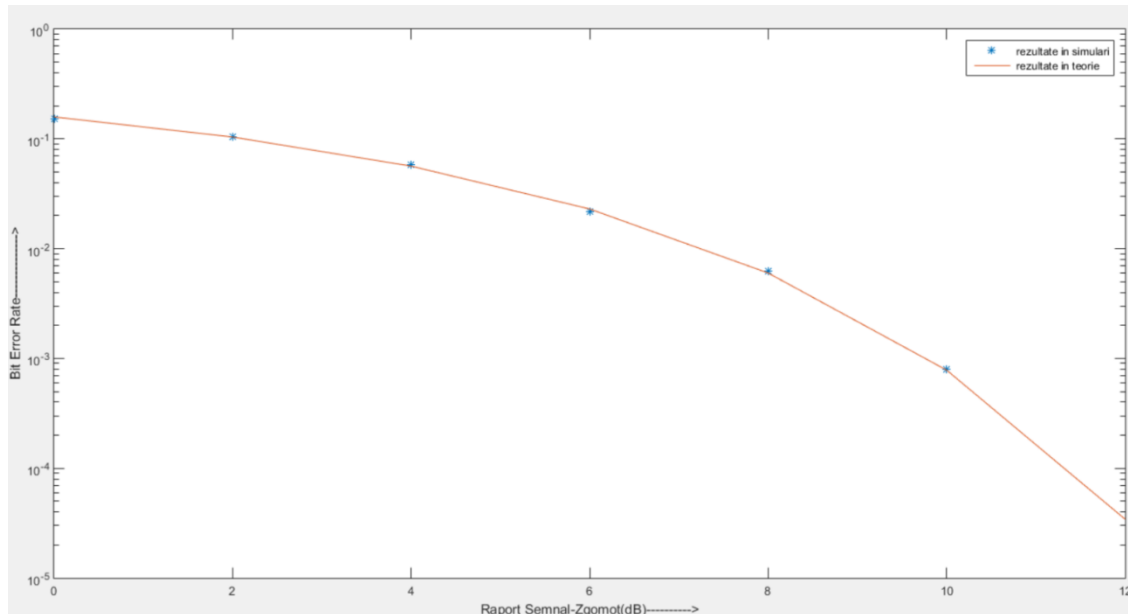

Figure 2: BPSK modulation simulation in AWGN channel

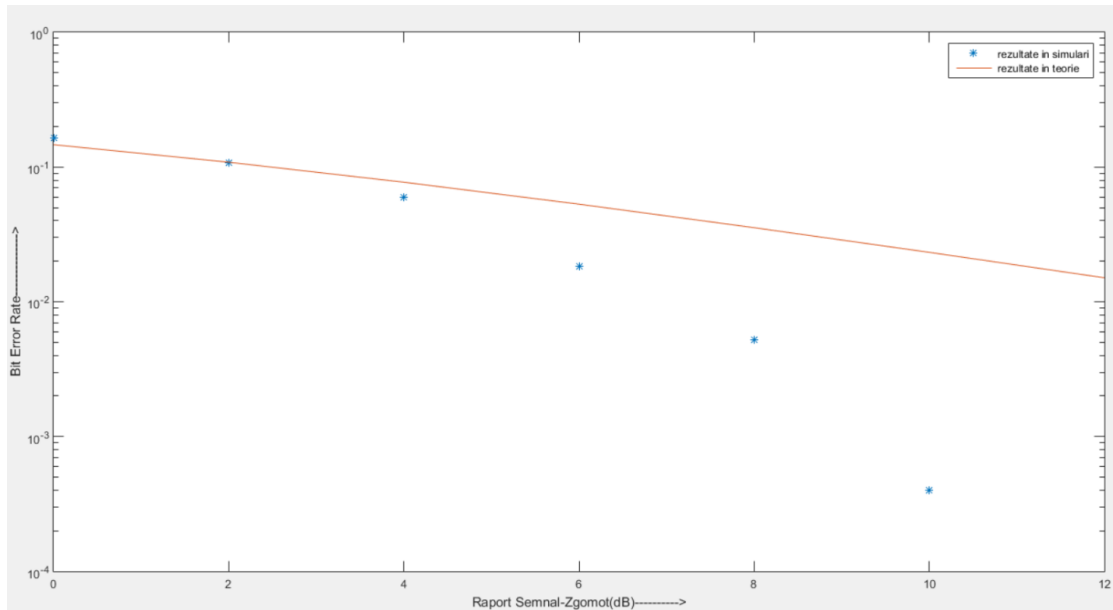

Figure 3. BPSK modulation simulation in Rayleigh channel

### Conclusions:

**Table 2**  
**BPSK in AWGN channel**

Ber vs SNR	2dB	4dB	6dB	8dB	10dB	12dB
Teory	0.104	0.056	0.023	0.006	0.0007	0.000003
Simulation	0.104	0.056	0.020	0.0076	0.0012	-

**Table 3**  
**BPSK in Rayleigh channel**

Ber Vs SNR	2dB	4dB	6dB	8dB	10dB	12dB
Teory	0.108	0.771	0.053	0.035	0.0232	0.015
Simulation	0.108	0.061	0.023	0.006	0.0006	-

- BPSK modulation performs better on the AWGN channel than on the Rayleigh channel, which is why its harmful fading effect.

- It can be observed that within the AWGN channel the values between the results in the simulations and those in the theory are very similar, being able to conclude that the results coincide approximately with a very low margin of error.

- When the signal is much stronger than the noise, the BPSK modulation in the Rayleigh channel has better simulation performance compared to the AWGN channel simulation, but we cannot consider that there is a significant difference (0.0076 is the BPSK BER in the AWGN at 8dB of SNR and 0.006 is BER of BPSK in Rayleigh at 8dB of SNR).

- Within the BPSK modulation in the Rayleigh channel, the results from the simulations came out better than in theory when this communications channel was not used.

### **BIBLIOGRAPHY**

- J. Proakis, M. Salehi, *Digital Communication, Fifth Edition*, Editura McGraw-Hill Higher Education, 2008;
- Feher, K., *Comunicații digitale avansate. Sisteme și tehnici de prelucrare a semnalelor*, vol.1, București, Editura Tehnică, 1993;
- [http://iota.ee.tuiasi.ro/~czet/Curs/Teledata/Cap2\\_Sisteme\\_de\\_comunicatii.pdf](http://iota.ee.tuiasi.ro/~czet/Curs/Teledata/Cap2_Sisteme_de_comunicatii.pdf), accessed in 01.02.2020.
- J. Proakis, M. Salehi, *Contemporary communication systems using MATLAB*, Editura Bookware Companion Series TM, 2009;
- J. Proakis, M. Salehi, *Digital Communication, Third Edition*, Editura McGraw-Hill Higher Education, 2008;
- Munteanu, V., *Teoria Transmiterii Informației*, Editura „Gh. Asachi”, Iași, 2001;
- Spătaru, A., *Teoria Transmisiunii Informației*, Editura Didactică și Pedagogică, București, România, 1983;

# THE APPLICABILITY OF COMMUNICATIONS PATENTS AND THE POSSIBILITY OF CAPITALIZATION

Elena MIRICĂ

“Nicolae Bălcescu” Land Forces Academy, Sibiu

elenamirica19@gmail.com

Scientific coordinator: Assoc.Prof.Eng. Silviu Mihai PETRIȘOR, PhD

**Abstract:** *The creation of a unitary patent system in the international space facilitates the free movement of goods and services. This free will facilitated the initiative of the human mind to express itself without limits, so the field of research has grown exponentially in recent years. As a result, patent and intellectual property law legislation has acquired clear, standardized forms both nationally and internationally. The legislative bodies were transformed in the same way. In this article it will be studied how some patented communications inventions in Romania are created and whether they have applicability in the field in which they fall. Specifically speaking, it will be observed how a series of patented inventions manage to move from the patent stage to the invention stage actually used in the domain to which it relates or even to other fields, if applicable.*

**Keywords:** patent, inventor, property law, communications, capitalization

## 1. The current setting- where are we?

The creation of a harmonized set of regulations in the field of intellectual property law in the international space is based on the development of the internal market, and the patents are a central element of the national economic systems from the perspective of the financial elements, which are the application of the invention in an industrial field. Moreover, the creation of a unitary patent system in the international space facilitates the free movement of goods and services.

We are all aware, without a doubt, of the huge changes produced in the world economy, regarding the highly developed international trade through its liberalization, but also of the free exchange, of the cultural exchanges, as an effect of the phenomenon of globalization that they developed as a result of the fall of barriers and interdependence between states. It can be easily observed that the economic life at the beginning of the third millennium, is experiencing an unprecedented development that has brought new actors from different geographical areas to the center of the world economic scene.

Global Innovation Index 2019 reveals that the global economy is losing momentum and that investment and productivity growth are sluggish. Global foreign direct investment has fallen. And public research and development expenditure in some high-income countries that drive technological advances is very slow. Such spending is central to funding basic and other forward-looking research. Protectionism is also on the rise. These uncertainties are slowing forward-looking investment in innovation and putting global innovation networks and the

diffusion of innovation at risk. Innovation remains concentrated in a few wealthier economies and significant knowledge gaps persist between developed and developing economies. However, the good news is that today all economies are prioritizing innovation to promote their social and economic development goals and are actively seeking to improve their innovation performance. In general, innovation is flourishing globally. <sup>[1]</sup>

## **2. Legislative elements**

The patent is a specific protection title, issued by a body of the state administration, which has the following characteristics: <sup>[2]</sup>

- Is issued by the state administration body, at the request of the inventor or his successor in rights;
- The patent protected creation is not one of form but a substantive creation;
- Creation must meet the conditions required for protection;
- Confirms the author's inventor status, his right of priority and grants him an exclusive right to exploit the limited pedestrian invention;
- The holder also has other rights, besides the exclusive exploitation;
- After the expiry of the validity period, the invention passes into the public domain and can be freely exploited by third parties

The patenting process is quite long, as it involves the completion of a standard form, the preparation of a technical documentation (which must contain the description of the invention, the claims, any drawings and the summary), the payment of costs, activities that require between 2 and up to 4-5 years. The patent application must also be accompanied by a summary of the patent which is filed no later than 2 months before the date of publication of the application. The invention must be presented in the patent application sufficiently clear and complete so that one skilled in the art can achieve it.

## **3. Targets-challenges**

The general objective of the article is to study how Romanian patented communications inventions are created and whether they have applicability in the field in which they fall. Specifically, the purpose of this paper is to observe how a series of patented inventions manage to move from the patent stage to the invention stage effectively used in the domain to which it relates or even to other fields, if applicable. This doubt is due to the fact that in recent years, the role of patented works has been reduced only to a medal received at a salon of invention or a diploma on the wall. In addition, about 4% of the patented works manage to be used, that is, to pass from the property of the inventor to that of a company.

If an invention is patentable, it does not necessarily mean that it will give rise to a commercially viable technology or product. Therefore, a careful evaluation of the pros and cons and an analysis of the possible alternatives are essential before filing a patent application. A patent can be expensive and difficult to obtain, maintain and apply. Whether or not to file a patent application is a strictly business decision. This should be based, first of all, on the likelihood of obtaining useful commercial protection for the invention which seems to bring serious benefits from its possible use in the business. Certain factors need to be considered in deciding whether or not to file a patent application.

## **4. Indicator criteria**

In meeting these ideas the respective patents will be evaluated by a series of criteria that would indicate if they are favorable or not in order to obtain a profit. These criteria will constitute the specific objectives of the dissertation work:

- the condition of an existing market for the respective invention

- the possibility of existing alternatives for the respective invention, in comparison with the one being questioned
- the parallel between the ability of the invention to improve an already successful product and its launch as a new product
- the probability of potential investors, respectively customers for the concession, which is inclined to provide support to put the product on the market
- the comparison between the possibility of easily designing the invention using the resulting product and the possibility of designing another product more efficient than the product being compared
- the competition perspective regarding the invention and patenting of what was invented.

Evaluating each patent through this list of criteria, it is expected that some hypotheses will be developed that could explain their success or failure in the market.

## **5. Hypotheses**

On the side of failure, they could be of the form:

- the patent was not issued following a thorough market study;
- the duration of obtaining the patent exceeded the expectations that were running on the market at the time that the market study was made;
- the inventor tried to carry out the patent-specific procedures, including foresight factors on his own, but did not have the necessary knowledge to consider the possibilities that an expert in the field would be more than capable of perceiving;
- the purpose of the inventor was not to use the product as a source of income, but rather to turn it into an official recognition of its merit at a national or international level.

On the success side, they could be of the form:

- the patent was invented following a thorough market study;
- in the process of obtaining the patent, its probability of meeting the medium and long term market requirements was taken into account;
- the inventor was either well trained, managing to take into account the factors that the experts set, or he realized that he was out of the situation and consulted specialists in the field, to ensure his success;
- the inventor's purpose was, in addition to an official recognition of its merits, the valorization of the product in a source of income, be it a partnership or the transfer of rights over production;

## **6. Exhibits**

### **6.1. Exhibit A**

The first patent application is application RO130953A2, “Methods, systems and computer readable support for packet data traffic distribution through communication protocol based on IP (GTP) for the transport of general data transmission services organized in radio channel packet (G PRS)”.



(12) **CERERE DE BREVET DE INVENȚIE**

(21) Nr. cerere: **2014 00518**

(22) Data de depozit: **04/07/2014**

---

(41) Data publicării cererii: **26/02/2016** BOPI nr. 2/2016

(71) Solicitant: **IXIA, A CALIFORNIA CORPORATION,**  
26601 WEST AIGOURA ROAD,  
CALABASAS, CA, US

(72) Inventor: **BONDRESCU ADRIAN LUCIAN,**  
STR.ȘTIRBEI VODĂ NR.87, BL.25 C. SC.A,  
ET.8, AP.22, CARACAL, OT, RO;

(74) Mandatar: **RATZA ȘI RATZA SRL, B-DUL A.J. CUZA,**  
NR. 52-54, SECTOR 1, BUCUREȘTI

---

(54) **METODE, SISTEME ȘI SUPORT CITIBIL DE CALCULATOR PENTRU DISTRIBUIREA TRAFICULUI DE PACHETE DE DATE PRIN PROTOCOLUL DE COMUNICAȚII BAZAT PE IP (GTP) PENTRU TRANSPORTUL SERVICIILOR GENERALE DE TRANSMISIIDE DATE ORGANIZATE ÎN MOD PACHET PE CANAL RADIO (G PRS)**

(57) Rezumat:

Invenția se referă la o metodă, un sistem și un suport citibil de calculator, pentru distribuția traficului prin protocolul de comunicații bazat pe IP, GTP, și este destinată testării echipamentelor de rețea de telefonie mobilă. Metoda conform invenției, având loc la un simulator de nod de rețea configurat pentru a distribui pachetele de date GTP încapsulate între o multitudine de procesoare asociate cu simulatorul de nod de rețea, constă în recepționarea unui pachet de date GTP încapsulat, asociat cu un dispozitiv de utilizator, în care pachetul de date GTP include un antet GTP cu un identificator de punct final legat de GTP, care indică un procesor din multitudine de procesoare, determinarea procesorului de procesare a pachetului de date GTP, folosind identificatorul de punct final legat de GTP, și trimiterea pachetului de date GTP către procesor, pentru procesare. Sistemul conform invenției cuprinde un simulator de nod de rețea (200) care include un modul de distribuție (202) și o multitudine de procesoare (204-218), și este configurat pentru a distribui pachetele de date GTP încapsulate între procesoarele din multitudine de procesoare. Suportul citibil de calculator, conform invenției, conține instrucțiuni executabile de calculator, care, atunci când sunt executate de un procesor, comandă calculatorului să recepționeze pachetul de date GTP, să determine procesorul de procesare a pachetului de date GTP, utilizând identificatorul de punct final legat de GTP, și să trimită pachetul de date GTP, pentru procesare.

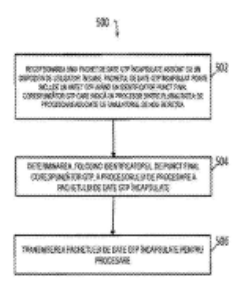

Fig. 5

Figure 1. Patent application RO130953A2

The invention relates to a method, a system and a computer readable medium, for traffic distribution through the communication protocol based on Internet Protocol, GTP and is intended for the testing of mobile network equipment. The method (taking place at a network node simulator) consists of receiving an encapsulated GTP data packet, associated with a user device, in which the GTP data packet includes a GTP header with a GTP endpoint identifier and sending GTP data packet to the processor for processing. The system comprises a network node simulator that includes a distribution module and a plurality of processors, and is configured to distribute encapsulated GTP data packets between the processors in the plurality of processors. The computer readable media contains executable computer instructions, which, when executed by a processor, command the computer to receive the GTP data packet, determine the processor processing the packet, and send the GTP data packet for processing.

Taking into account that the applicant of the invention is a foreign company, reaching out to Romanian inventors, it's obvious that the market is well studied, the investors are in line and because the configuration of the product it's simple and cheap, the alternative of the product would be out of question, in terms of effectiveness and improvement. Even if the competition is present, the design of the product has already made sure that the market would play in their favor, at least until major improvements would change the market perspectives. Therefore the hypothesis that would express the best their outcome is that the inventor or the applicant has a rigorous market study, the possibilities of the product are established at least for a medium term and the inventors are of course compensated for their invention.

**6.2. Exhibit B**

The second patent application is application RO131697A0, "Broadband antenna and rectifier antenna made with this antenna, for collecting the electrosmog and converting it into electricity".

(12)

## CERERE DE BREVET DE INVENȚIE

(21) Nr. cerere: **a 2016 00553**

(22) Data de depozit: **02/08/2016**

(41) Data publicării cererii:  
**28/02/2017** BOPI nr. 2/2017

(71) Solicitant:  
• **INSTITUTUL NAȚIONAL DE CERCETARE  
DEZVOLTARE PENTRU TEHNOLOGII  
IZOTOPICE ȘI MOLECULARE (INCOTIM),  
STR. DONATH NR. 67-103 POB 700,  
CLUJ-NAPOCA, CJ, RO**

(72) Inventatori:  
• **SURDUCAN EMANOIL,  
STR. GHEORGHE DIMA NR. 10, AP. 19,  
CLUJ-NAPOCA, CJ, RO;**  
• **SURDUCAN VASILE, STR. NUCULUI  
NR. 8, CLUJ-NAPOCA, CJ, RO;**  
• **NEAMȚU CAMELIA, ALEEA IEZER NR. 1,  
BL. L 5, SC. 5, ET. 4, AP. 49, CLUJ NAPOCA,  
CJ, RO**

(54) **ANTENĂ DE BANDĂ LARGĂ ȘI ANTENĂ REDREȘOARE  
REALIZATĂ CU ACEASTĂ ANTENĂ, PENTRU COLECTAREA  
ELECTROSMOGULUI ȘI CONVERSIA LUI ÎN ENERGIE  
ELECTRICĂ**

(57) Rezumat:

Invenția se referă la o antenă de bandă largă și la o antenă redresoare construită cu aceasta, destinate recepției câmpului electromagnetic din domeniul de frecvențe 800 MHz...13 GHz, și conversiei energiei electromagnetice în energie electrică. Antena de bandă largă, conform invenției, realizată în tehnică microstrip-fantă, cuprinde un strat (11) conductor depus pe un suport (12) dielectric de constantă dielectrică cunoscută, având o geometrie în spirală, cu două brațe (1, 2) metalice, terminat fiecare cu o structură de trei rezonatori (6, 7, 8) tip fantă dielectrică, și alți trei rezonatori (3, 4, 5) tip microstrip conductor. Antena redresoare, conform invenției, este formată din antena de bandă largă, între brațele (1, 2) căreia este adăugat un circuit de detecție și dublare de tensiune, conectat, prin niște treceri (14, 15) metalizate, la două borne (16, 17) realizate pe un strat (13) metalic de pe fața inferioară a antenei.

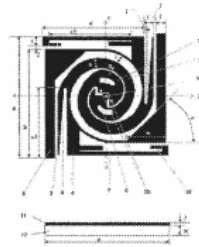

Fig. 1

Figure 2. Patent application RO131697A0

The invention relates to a broadband antenna and a rectifier antenna constructed therewith, intended for the reception of the electromagnetic field in the frequency range 800 MHz- 13GHz and the conversion of electromagnetic energy into electrical energy. The broadband antenna, according to the invention, made in microstripling technique, comprises a conductive layer deposited on a dielectric support of known dielectric constant, having a spiral geometry, with two metal arms, each finished with a structure of three dielectric slot resonators, and three other conductive microstrip resonators. The rectifying antenna, according to the invention, is composed of the broadband antenna, between the arms of which is added a circuit of detection and doubling of voltage, connected, by some metallic passes, to two terminals made on a metallic layer on the lower face of the antenna.

This time, the application comes from a research institute, meaning that the outcome might not be capitalization and instead they might want exclusive rights to their idea as a stepping stone for future research in the field. On the other side, like any other institution, they need capital for research and so, beside recognition, the income that the invention would produce would be well received. Being a research facility, their knowledge about patent law is expected to be sturdy, as well as their legal team that handles the procedures.

Therefore the hypothesis that would convey the conclusion is clearly a bright one, even if the final purpose might not be capitalization, as their expertise is top notch.

### 6.3. Exhibit C

The third patent application is application RO132837A0, “process for installing the radio receiver with multiple protections for electrical discharges and with extended temperature range”.

(21) Nr. cerere: **a 2018 00187**(22) Data de depozit: **19/03/2018**(41) Data publicării cererii: **28/09/2018** BOPI nr. 9/2018(71) Solicitant:  
• **DUMITRU LUCIAN IONEL**,  
STR. EROU ȘERBAN ION, NR. 36,  
VOLUNTARI, IF, RO;  
• **MATEESCU RADU MIHAI**,  
STR. VLAICU VODĂ, NR. 7, BL. C8, AP. 93,  
SECTOR 3, BUCUREȘTI, B, RO(72) Inventatori:  
• **DUMITRU LUCIAN IONEL**,  
STR. EROU ȘERBAN ION, NR. 36,  
VOLUNTARI, IF, RO;  
• **MATEESCU RADU MIHAI**,  
STR. VLAICU VODĂ, NR. 7, BL. C8, AP. 93,  
SECTOR 3, BUCUREȘTI, B, RO(54) **PROCEDEU DE INSTALARE A RECEPTORULUI RADIO  
CU PROTEȚII MULTIPLE LA DESCĂRCĂRI ELECTRICE  
ȘI GAMĂ EXTINSĂ DE TEMPERATURĂ**

(57) Rezumat:

Invenția se referă la un procedeu de instalare a unui receptor radio cu protecții multiple la descărcări electrice, și cu gamă extinsă de temperatură. Procedeu conform invenției cuprinde o etapă de instalare a receptorului radio la înălțime, pe un pilon, într-o incintă metalică etanșă, prevăzută cu un ventilator care pornește automat la o anumită temperatură, setată de utilizator cu ajutorul unui senzor de temperatură, o etapă de realizare a unei separări galvanice a receptorului radio față de o cameră tehnică de la baza pilonului, definind astfel două niveluri echipotențiale, unul la nivelul incintei metalice, și al doilea la nivelul camerei tehnice de la baza pilonului, și o etapă de utilizare pe intrarea antenei în incinta metalică a unui atenuator de valoare mică, formând o cale de descărcare a electricității atmosferice statice.

Revendicări: 7  
Figuri: 3

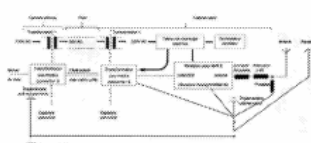

Fig. 1

Figure 3. Patent application RO132837A0

The invention relates to a process for installing a radio receiver with multiple protections for electrical discharges, and with extended temperature range. The process according to the invention comprises a phase of installing the radio receiver at height, on a pillar, in a sealed metal enclosure, provided with a fan which automatically starts at a certain temperature, set by the user with the help of a temperature sensor, a phase of achieving a galvanic separation of the radio receiver from a technical chamber at the base of the pillar, thus defining two equipotential levels, one at the level of the metal enclosure, and a second one at the level of the technical room at the base of the pillar, and a phase of using a small value attenuator on the antenna entrance in the metallic enclosure, forming a way of discharging static atmospheric electricity.

This last application is not backed up by a company or a research institute thus the inventors are also applicants. After a review of the patent application, it is clear that they did a throughout study and that the market would receive their idea very well as their product solves a lot of shortcomings that their actual competition have. As the application has been sent in 2018, in the near future they should receive the fruits of their labor, meaning recognition and surely profit from selling or partnership.

This third application leans on the successful side of the hypotheses that were formulated, meaning that they studied the market, and their inventions came as a result of the faults that were found in similar, actual products. This type of idea, compensates as well on a medium and long term market requirements.

## 7. Conclusion

Drawing the final conclusion, it can be stated that communication and IT technology is a domain that is bound to be successful and profitable if the inventors are willing to involve themselves in the entire process of the market study, of the actual research that is being made and if their ambition becomes much more than official recognition. These things can be

acquired through hard work, commitment and desire to overcome the walls that stand in the way of success.

#### **REFERENCES**

- [1] Catherine Jewell, *Wipo Magazine no. 4*, August, 3.
- [2] Viorel Roş, *Dreptul proprietăţii intelectuale*, Global Lex (Bucureşti- 2001), 309-310.

#### **BIBLIOGRAPHY**

Jewell, Catherine ,*Wipo Magazine no. 4*, August.  
Roş, Viorel, *Dreptul proprietăţii intelectuale*, Global Lex (Bucureşti- 2001).

# CONCEPTUAL ANALYSIS OF THE TECHNICAL SYSTEMS AVAILABILITY

Doru MOȚ

“Nicolae Bălcescu” Land Forces Academy, Sibiu

motzdoru@yahoo.com

Scientific coordinator: COL Assoc.Prof.Eng. Ioan VIRCA, PhD

**Abstract:** *The problem of determining the probability of functioning of the technical systems, of estimating their failure, their maintenance and ensuring a high level of operational availability, represents a major concern of the specialists in the field, due to the fact that the safety in operation and the security of the current technical systems, interconnected or located in dependency report with other large systems, requires analysis both in the plane of defect distribution and in the distribution of the maintenance activity of the technical systems. The present article aims to realize the conceptual link between the reliability, the maintainability and the availability of the technical systems. This analysis will be performed taking into account the fact that all three concepts have a probability character, so the laws of probability theory can be applied, if they are correctly quantified. Accordingly, the method of calculating the availability will be the same as that used for calculating the reliability of technical systems with serial or parallel assembly. Therefore, reliability and maintainability strongly influence availability. In order to keep these two factors at a high level, there is a need to renew the technical systems, periodically or at different times, but without exceeding the threshold of their inefficiency and thus the occurrence of failure rates and immobilization times below the minimum allowable values. The current technical systems can maintain a high availability coefficient, but with high costs. In conclusion, the concept of availability needs to be analyzed and developed in relation to the missions and activities in which technical systems are involved.*

**Keywords:** operational availability, reliability, maintainability, technical system, probability theory.

## **1. The state of research in the field of availability of operational technical systems.**

### **Conceptual approaches**

The operational availability of combat systems and equipment is a key component of the armed forces' ability to conduct hostilities in an armed conflict through actions that involve raising combat capacity. Operational availability is an essential parameter of performance, according to which the operating system (armament, technique, etc.) is essential to be used and available throughout its entire life cycle.

The study of the concept of operational availability and its influence on the way of designing, operating and the life cycle cost of the military technical systems leads to the enhancement of their capabilities.

Operational availability is determined by the calculation of numerous supportability functions. The reference value used in the calculation should be compatible with the structure of the system, its role being to indicate the equipment that provides the best fighting ability. The operational availability of combat equipment is the main element studied in the Department of Defense, representing a performance parameter that a technical system can achieve throughout its life cycle.

The amount of operational availability must be calculated by the personnel responsible for the procurement of endowment programs of the armed forces and it must be ensured that the strategy which supports the combat system ensures the required value of operational availability and operational safety. To determine the causes and possible solutions for an inadequate value, it is necessary to identify and size the factors that characterize the operating and failure times. Operational safety (OS), from a systemic point of view, represents the overall ability of a technical-economic system to fulfill its mission for which it was designed and is characterized by four components: reliability, maintainability, availability and operational safety [1].

Recently, lots of projects have been developed, not only in the industry branch, but the majority of them had the value of more than one billion dollars. The complexity of the design of most of the projects and, also, the non-existence of a proper process of evaluating the integrity of the projects design are two of the issues that are rising a great interest for this type of researching, in almost all the engineering braches. Taking these issues in consideration, the project directors had to raise the amount of budget that was initially planned for developing the projects till the end state.

Reliability can be defined by the instrumentality of the theory of probability as the rate of success of the operation, but it still has to take in consideration a minimum risk of failure or damages. Any further failures must be analyzed very well through an over particular process of evaluation in order to reduce at minimum the consequences of failure of any system or equipment.

**2. Availability** is a specific process of the maintenance system that refers to the maintenance of the systems equipments. An assessment of the consequences of the failures of the operational systems is absolutely necessary in order to obtain a proper design of availability, as well as the critical needs to restore the normal functioning of the system according to the operating specifications.

**3. Maintenance** is that process, which takes into consideration the failure status of the systems. Maintenance design requires an assessment of the accessibility and "affordability" of the component systems and their related equipment, in the event of a defect, as well as of the integrated systems closed during the planned maintenance [2].

**4. Security** is the issue that includes three categories as following: the protection of the personnel, equipment protection, and the last one, but not the least as importance, environmental protection. In other words, safety can be defined as "something that does not involve a risk "if the risk is defined as" probability of failure, loss or damage". Design for safety is inevitable in the process of developing the reliability and maintenance of systems and related equipment. Protection of the natural environment in engineering design at the industrial level is referring to the prevention of defection of operational systems that includes environmental problems, predominantly in the treatment of waste and emissions resulting from operations of chemical processing, working processes at very high temperatures, hydrometallurgical processes and minerals, etc.

These four themes gathered together have as a result the methodology that provides a good level of engineering design with the system integrity that was expected. This methodology assures the ways by which complex engineering patterns can be analyzed and revised in a proper way. This type of analyzing and reviewing are achieved not only with an

importance growth on individual systems, but also with a future view of the critical compounds and complex integration of all linked systems and equipments, in order to obtain the end state desired for the values of reliability, availability, maintenance and safety (integrity values).

This analysis is called the RAMS analysis [3]. Those industries that apply product assurance methods have undoubtedly witnessed amazing revolutions of knowledge and techniques to match the equally astounding progress in technology, especially in the electronic, micro-electronics industry. Many technologies have achieved a breakthrough in the last two decades. In fact, most production systems generated today will be "technologically obsolete" in the not too distant future. Therefore, it is also necessary that the development ideas, knowledge and techniques used for the proper management of application and maintenance of newly developed systems are compatible and adaptable, otherwise they will be deprived. This also applies to the concept of integrity engineering, and in particular to the integrity of engineering design.

The main objective of this study is the framing in the field of availability of an operational technical system with applicability in military organizations. The main objective entails the following specific objectives: defining the concepts in this field, identifying the needs in order to obtain satisfactory parameters of the availability of the operational technical systems, reducing the production costs and analyzing the methodology for solving the availability and efficiency problems in operation.

Before we start the planning process concerning the system availability, it is absolutely necessary to understand the following concepts related to availability:

**5. Continuity of the activity** can be defined as the potential of any institution or military units to manage with the interruptions in functioning (periods of time when the system is unavailable) and to assure the proper and continuous operation of important capabilities, such as stated in the agreements on the predefined level of service. To achieve a certain level of the organization continuity, an assembly of services, software, hardware and procedures must be selected, stated in a plan and then enforced and regularly practiced. The business continuity solution should take into consideration the information, the environment of the operations, the services, the application hosting environment and the user interface. Only if all of these issues are reached and up, the continuity of the organization is a good and complete outcome. The business continuity plan consists of damage recovery process and high availability of the system.

**6. Disaster recovery** consists of a plan with specific activities that have to be done in case of a complete interruption of system activity, for example a natural cataclysm. Disaster Recovery stands for all the resources, plans, services, and procedures which will be used to regain the significant applications and to continue the daily operations using remote location. This disaster recovery plan includes a stated purpose of disaster recovery (for example, continuing operations within a maximum of eight hours) and takes into account acceptable levels of degradation.

**7. High availability** can be defined the capability to deal with any interruption (planned, unplanned and disasters) and to make possible the proper functioning of all the significant functional services areas in a continuous way. The most important objective is that the percentage of the interruption time to be less than 0.001% of the total necessary functioning period in order to achieve the best results. The disparity between high availability and disaster recovery usually stands for lower recovery time goals (seconds or minutes) and more demanding recovery point goals (without user interruption).

Availability can be evaluated by taking in consideration the outages, which are periods of time when the equipment cannot be used as in a normal way. A scheduled outage can be used to run batch jobs, backup system backups, or apply fixes.

The backup window error is the interval that the system may be unavailable to the users, while backup operations are performed. The backup window is a planned outage, which is usually placed at night or on a weekend, when the system has less traffic. An unplanned outage is usually caused by a malfunction. You can recover from some unplanned outages (such as disk errors, system errors, power outages, program errors, or human errors) if you have a proper backup strategy. But to be able to make the recovery from an unplanned outage that causes a complete loss of the system, such as a tornado or fire, it is necessary to have a detailed disaster recovery plan. High availability solutions ensure fully automated error retrieval on a backup system to ensure continuous operation for users and applications. These solutions should provide an immediate recovery point and a shorter recovery time than in the case of other solutions.

Unlike disaster recovery, where entire systems are interrupted, high availability solutions can be customized for individual, critical resources within a system; for example, a particular application instance.

After understanding the availability at a basic level, it is important to estimate the individual availability needs. Higher availability is more expensive than low availability. We need to balance needs and services with the full cost of implementing and maintaining these availability solutions.

We need to make sure that we have analyzed very well the needs of the military structure that will use the purchased system (s), to decide what level of availability we can afford to maintain.

In order to reach the maximum efficiency and a high degree of availability of the system, it is necessary to allocate funds that allow the running of interactive models and studies to show how, through investments that allow the evaluation of new capabilities, the life cycle costs will be reduced, improving the sustainability of the system [4].

The analysis process includes the following steps [5]:

1. defining the purpose of the analysis;
2. identification of the reference direction and alternatives;
3. identification of the basic rules and the risks assumed;
4. selecting the representative elements;
5. identification of the technique to be evaluated;
6. selecting or making a model;
7. identification of input data and origin of material flows;
8. estimation and evaluation of support factors;
9. performing a careful analysis, identification and verification of the basic elements;
10. risk and uncertainty analysis;
11. recommendations;
12. preparing an analysis report.

Because availability is a problem in our day, its calculation formula is identical to that of the reliability of the technical systems in series or in parallel. Therefore, we can distinguish two factors that directly influence the availability of a technical system, namely reliability and maintainability.

## 8. Conclusion

In conclusion, in this context of maintaining at a high level of the two factors, there is a need to renew the technical systems, periodically or at different times.

## REFERENCES

- [1] Villemur A., *Surete de fonctionnement des systemes*, (Paris: Ed. Eyrolles, 1988).
- [2] *Chapouille, producție.: Maintainabilité. Maintenance, TechniCues de l'Ingenieur*, Vol. T 4, 305, (France, 2004).



[3] Szkoda M, Kaczor G., *RAMS analysis of railway vehicles' lifecycle*, (Cracow University of Technology, 2017).

[4] *Analysis Handbook, A Guide for Performing an Analysis of Alternatives*, Office of Aerospace Studies, (SUA, 2002).

[5] Ghiță Bârsan, *Modelarea capabilităților unui sistem tehnic militar cu ajutorul conceptului de disponibilitate operațională*, Buletinul Stiintific al Academiei Forțelor Terestre, nr. 2 (18), pag. 119-133, (Sibiu: Editura Academiei Forțelor Terestre, 2004).

#### BIBLIOGRAPHY

*Analysis Handbook, A Guide for Performing an Analysis of Alternatives*, Office of Aerospace Studies, SUA, 2002.

*Chapouille, producție.: Maintenabilité. Maintenance*, TechniCues de l'Ingenieur, Vol. T 4 305, France, 2004.

Ghiță Bârsan, *Modelarea capabilităților unui sistem tehnic militar cu ajutorul conceptului de disponibilitate operațională*, Buletinul Stiintific al Academiei Forțelor Terestre, nr. 2 (18), pag. 119-133, Sibiu: Editura Academiei Forțelor Terestre, 2004.

*Operational Availability Handbook, A Practical Guide for Military Systems, Sub-Systems and Equipment*, Department of the Navy, SUA, 2003.

Szkoda M. and Kaczor G., *RAMS analysis of railway vehicles' lifecycle*, Cracow: University of Technology, 2017.

Vilcu A., *Cercetări si contribuții privind optimizarea siguranței în funcționare pentru susținerea strategiilor de producție-calitate*, teză doctorat, Iași: Universitatea tehnică "Gheorghe Asachi", 2018.

Vilcu A., Verzea I. and Chaib R., *Dependability breakeven point mathematical model for production - Quality strategy support*, ModTech international Conference, Iași, 2016.

Villemur A., *Surete de fonctionnement des systemes*, Paris: Ed. Eyrolles, 1988.

# **DETERMINING THE PROBABILITY OF FAILURE OF A REPAIRABLE TECHNICAL SYSTEM STUDY REGARDING THE ESTABLISHMENT OF A QUALITY AND QUANTITY ANALYSIS METHOD REQUESTED IN ORDER TO DETERMINE THE DAMAGING PROBABILITY OF THE REPAIRABLE TECHNICAL SYSTEMS**

Alexandru-Valentin NECULA

“Nicolae Bălcescu” Land Forces Academy, Sibiu

necula.alexandruvalentin@yahoo.ro

Scientific coordinator: COL Assoc.Prof.Eng. Ioan VIRCA, PhD

**Abstract:** *Nowadays the problem of repairable technical systems is an important objective during the technical system complete life cycle, starting from the projecting, production, testing stages, through using-repairing stage until removing them from use. This objective can be analyzed using total quality management (TQM) research methods. The purpose of this article is to analyze the technical systems reliability and to identify a total quality management method that can determine the repairable technical systems damaging probability.*

**Keywords:** repairable technical systems, fault tree.

The reliability of the technical systems is defined as the probability that a system will fulfill its designed function for a specified period of time, under predetermined conditions of use.

When referring to the reliability of a technical system, we must refer to all its component parts that have different reliability. The components of a technical system can mean physical equipment, hardware, software, interfaces, connections, human operator, procedures of use and last but not least, the support infrastructure. A system must be balanced in terms of reliability: all its components must have comparable levels of reliability, otherwise the most unreliable component determines the reliability of the system, it is the weakest link in the chain.

Reliability is inseparable from the ability of the system to be restarted after failure. The probability that the system is in good working order is restored by proper operations performed over a certain period of time is called maintainability. The assembly of all the

activities carried out to maintain or restore the state of good functioning is called maintenance.

The study of the reliability of the systems by the fault tree method is a deductive method of analysis that is carried out from top to bottom and that allows to identify the causes that can lead to the defined peak event. A failure tree is an organized graphical representation of conditions or factors that cause or contribute to a system failure, called a "peak event".

#### **Basic principles regarding the shaft failure**

The peak event is a consequence of the combinations of all the input events. It is also called the final event or peak consequence.

The representation of a defect tree is made in a form that can be easily understood and analyzed to allow identification:

- the factors affecting the peak event considered;
- factors that affect the reliability and performance characteristics of a system, for example, design deficiencies, environmental or operating demands, component failure modes, operator errors, software package defects;
- events that affect the functioning of several components, canceling the benefits of redundancies or parts of a system.

In the construction of the fault tree, it starts from the peak event and works with the following elements:

- logic gate - symbol that is used to establish symbolic links between the output event and the corresponding inputs; reflects the type of logical (Boolean) relationship between the input events so that the output event can occur.
- event - the occurrence of a condition or an action that leads to failure system;
- primary event - event that underlies the fault tree; it can be an event that can no longer be developed in the analyzed tree or an event that has been developed elsewhere based on a group of events and gates and is introduced as an event already studied;
- single event failure - a failure event that may cause general system failure or which, independent of other events or their combinations, may cause the peak event;
- common cause - cause of multiple events;
- event repeated event which is an entry for several higher level events.

#### **Methods of analysis**

The defective shaft method is suitable for analyzing systems comprising several functional or dependent subsystems. It is usually applied to the design of nuclear power plants, transport systems, communication systems, chemical or industrial processes, railway systems, medical systems, and last but not least IT systems.

Defective shafts allow both qualitative and quantitative analysis.

The primary purpose of qualitative analysis is to identify the minimal cut set to determine how the basic events influence the peak event. Quantitative analysis can be used to calculate the probabilities of the occurrence of the peak event and the intermediate events when the probabilities of the primary events are known.

A failure tree analysis aims to:

- identifying the causes or combinations of these causes that lead to the peak event;
- determining how a particular system's reliability feature meets a specified requirement;
- determining the potential failure modes or factors that contribute most to the probability of failure or unavailability of the repairable system, in order to identify possible improvements that can be made to the reliability of a system;

- identifying potential failure modes that may cause a security problem, assessing the appropriate probability of occurrence of security events and the possibility of reduction;
- searching for an event or combination of events that are the most likely cause of the peak event occurrence;
- calculating system availability and failure rates or of its components represented in the fault tree, if a state can be declared as stable, and any repairs are independent of each other (the same limitation as for the success path diagram / block diagram of reliability).

The failure tree method used in the study of system reliability starts from the idea that the failure process can be quantified structurally, so that any failure of the system is the result of a quantified sequence of states of the failure process.

For any practical application, any logical function can be obtained by using only the three basic logical functions - fundamental functions of Boolean algebra: the negation function (NO), the logical product (AND) and the logical sum (OR). As the mathematicians say, these three logical functions define a complete system.

For each event that appears in the fault tree it is recommended to make a list with the name or description of the event, to code events and to calculate the probability of occurrence.

If an event is a repeated event or for a common cause, it is presented in the fault tree repeatedly, but with a warning flag. All repeated or common cause events in the tree must have the same code and must be marked with a transfer-entry symbol or another symbol chosen specifically for a particular failure tree. This rule applies to all repeated or common cause events except the lowest level event as a whole, which is marked with a transfer-exit symbol. In some fault tree diagrams, the symbols for repeated or higher primary events are the same.

### **Component elements of the failure tree**

From a structural point of view, the defect tree is associated with it the following concepts:

- the primary elements - the components or elements that are at the basic level;
- basic defects - defects of the primary elements;
- unwanted event - defect status;
- failure mode - the set of simultaneous defective elements that lead to system failure;
- minimum failure mode - the smallest set of primary components, leading to system failure;
- the hierarchical level - the totality of the elements that are structurally equivalent, occupying equivalent positions in the structure of the fault tree.<sup>1</sup>

In the following figure is given the simplest representation of a failure tree, consisting of primary events, interconnected through a Boolean logical structure, which indicates the possibilities, in which events can be combined to cause system failure. If the system has more than one failure condition, a separate failure shaft must be built for each of them.

The fault tree is constructed from the peak event (system failure) until it reaches the primary events (component or subsystem failure) by studying the logical interactions between these system events.

---

<sup>1</sup>Floarea BAICU, Reliability of computer systems: HyperionUniversity , 2012,51.

In the design phase, the defective shaft method allows to highlight some design deficiencies, vulnerable places and elements in the system.

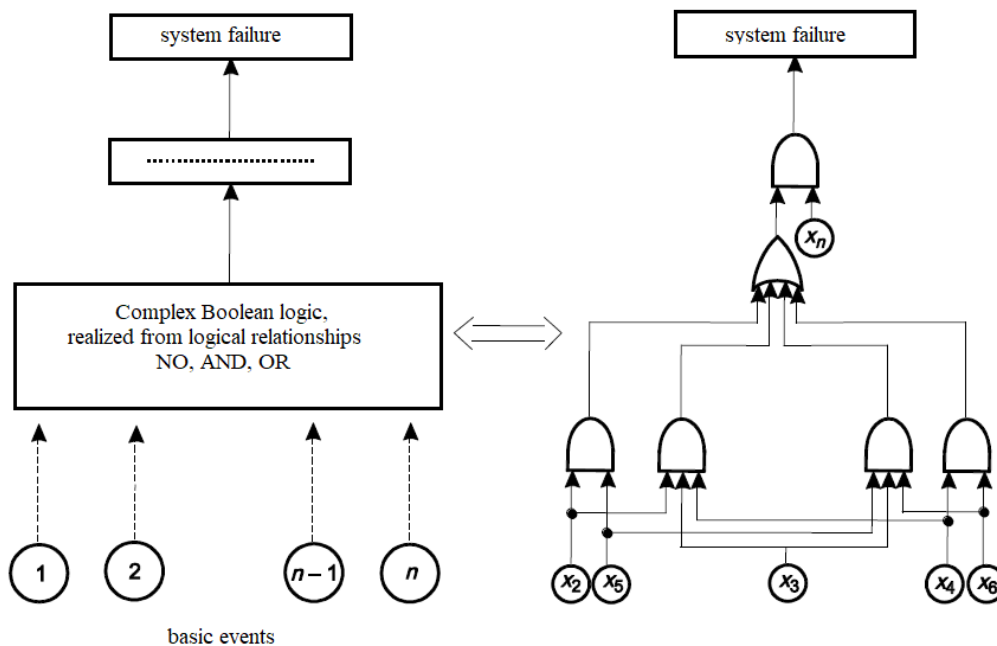

Figure 1 - Simple representation of a failure tree

The final consequence of a failure tree (peak event) maybe a failure in itself or an event. Here, the failure tree describes a defect or event that results from contributing events or other defects. In the fault tree analysis, certain combinations of events may be states or events, while others must be consistent with the consequence.

The state can be characterized by the probability of its existence at time  $t$ , and the event can be characterized either by the failure rate or frequency, or by the probability of occurrence of the event at time  $t$ .

### Evaluation of the probability of failure

The evaluation of the probability of failure uses the properties of the logic gates.

- exit of the gates NO, output = probability  $\Rightarrow P(\bar{A}) = 1 - P(A)$ . (1)

- exit of the gates AND, A defect and B defect  $\Rightarrow P(A \cap B) = P(A) * P(B)$  (2)

- exit of the gates OR, A defect or B defect  $\Rightarrow P(A \cup B) = P(A) + P(B) - P(A) * P(B)$ .<sup>2</sup> (3)

---

<sup>2</sup>J.D PALMER *Electronic-Module Environmental-Stress-Screening Data-Evaluation Technique*, Annual Reliability and Maintainability Symposium 1999, 70.

### **Conclusions**

For most systems, an analysis of the reliability of the system, taking into account the good functioning of all the component elements, leads to the realization of the tree graph.

A certain complex product, in the process of studying reliability, can be broken down into subsystems of different levels (subassemblies, blocks, elements, etc.). Depending on the purpose of the analysis, each such ensemble (at any level) can be considered as a whole, which is subject to self-research. So any subsystem, or even the system as a whole, can be considered as an object of study of reliability, which is carried out according to the same methodology as the study of an elementary component.

### **REFERENCES**

- [1] Floarea BAICU, Reliability of computer systems: Hyperion University , 2012,51.
- [2] J.D PALMER *Electronic-Module Environmental-Stress-Screening Data-Evaluation Technique*, Annual Reliability and Maintainability Symposium 1999, 70.

### **BIBLIOGRAPHY**

- Floarea BAICU, Reliability of computer systems: Hyperion University , 2012.
- J.D PALMER *Electronic-Module Environmental-Stress-Screening Data-Evaluation Technique*, Annual Reliability and Maintainability Symposium 1999

# GLOBALISATION FROM THE PERSPECTIVE OF INTERNATIONAL ORGANISATIONS

Dragoş-Constantin NECULA

“Nicolae Bălcescu” Land Forces Academy, Sibiu

eden\_dragos@yahoo.com

Scientific coordinator: MAJ Assist.Prof. Ionuț Alin CÎRDEI, PhD

**Abstract:** *The aim of this paper is to outline a current description of the security environment's globalisation through the lens of international organisations. Given the general process of globalisation it was inevitable that security would be caught in as well. Nowadays, organisations such as the North Atlantic Treaty Organisation or even the Interpol contribute to various aspects of national and international security. Nations collaborate like never before to secure their future. Cooperation among foreign nations is not always easy. Nations also compete, even in the face of imminent threats.*

**Keywords:** Globalisation; International; Security.

The notion of globalization appears in contemporary international public discourse more and more often. Globalization is always regarded as the main reason why a phenomenon manifests itself, indirectly and causally, in different parts of the world, generating waves of repercussions; this reality determines, among other things, the intensification of interdependence relations between states. The active agents that promote globalization, the subjects of this process, can be states, international organizations or even large corporations or companies with worldwide representation, including belonging to the mass media segment, entities engaged in the fulfilment of constitutional purposes or, as the case may be, statutory.

The diversity of the qualities of the active subjects of globalization, as well as the large number of them, demonstrate the substantial scope of this process and its significance in the current world context, conferring all the attributes of an important scientific research topic. Given that globalization is, above all, a process of interdependencies, a reality that brings into the same interaction plan subjects of international law from different areas of the globe, elements that, until recently, were not considered to be part of the same system of equations, the states have begun to adapt accordingly the national modalities of knowledge and management of the process in this case, including the first contact points existing at the level of their own defence systems, public order and national security.

Within an integrated and specialized approach, we appreciate that national defence systems, public order and national security (and, within them, the component institutions) constitute the first contact points of the states in relation to most of the repercussions of globalization. In some cases, they even determine and / or manage the effects of globalization, being responsible for exploiting the opportunities or counteracting the negative effects of this process, as well as maintaining the risks and threats to the national security plan at a reasonable level. In order to best serve the member state, we believe that national defence,

public order and national security systems, including their components, must go on a permanent path of adaptation to the challenges of this global process.

Thus, the dynamics of vulnerabilities, risks, dangers, threats and aggression against national security should be opposed by system states, as dynamic and flexible, defence, public order and national security. As a consequence, it is useful to point out some national ways of adaptation, taking into account the role of the state in the development of social processes, its areas of interest and responsibility, the need and the extent of promoting globalization models in accordance with the fundamental interests of the actors of this process, such as and national procedures for exploiting opportunities / countering threats or addressing new challenges in the international security environment.

At the end of the Cold War, the continent's unstable environment stimulated the regionalization of security issues. The process, points out the specialists in globalization, combined with the international initiatives, has produced a re-establishment of a cooperative or common security regime at global level, in the context of the UN reform.

WEU and OSCE take on new roles and responsibilities. International consultation and coordination mechanisms are created with scope on the internal problems of the Member States. Our continent is forming a new structure of collective security, which more deeply integrates the military and security aspects. Zbigniew Brzezinski notes that the security strategy of the twentieth century is outdated, given the new global vulnerabilities, with disastrous effects at the regional level. Regional security is a necessity imposed by many determinations: the challenges of the phenomenon of globalization, the great difficulties that are presently encountered by the states of the region, economically, ethnically, in environmental issues and beyond. In the Middle East, for example, economic and security deficits, in the opinion of analysts, cannot be solved on the grassroots by external force solutions, which generate phenomena of rejection, resentment.<sup>1</sup>

The Muslim problem must be "viewed from a regional rather than a global perspective, and through a geopolitical, not theological, prism." In the "new global Balkans", a space between the Persian Gulf and Xinjiang, Brzezinski sees a major challenge for the US at least a generation from here. Overwhelmed by violence, social injustice, massive demographic growth, the region will have to build security through US cooperation with its traditional partners: Turkey, Israel, India, Russia. Only they have their own internal security problems and, moreover, they have a security agenda that does not correspond every time with that of America. Oil, we could say, is at the heart of the security issue of the Central Asia and the Gulf region, where the US is heavily involved.

Therefore, their solution requires great efforts of regional and global cooperation. As in the view of the same American analyst, the security of the Southeast Asia region is determined by the cooperation of China, Japan and the USA. Important regional forums, such as ASEAN, OUA or OSA, set up on three continents (Asia, Africa and Latin America), institutionalize regional cooperation on security issues and multilateral dialogue, under the conditions of globalization. Returning to the Asian space, we will emphasize that an eloquent demonstration on the determinations of regional security and the report on regional security - globalization is made by Francis Fukuyama. He brings as an example the example of Northeast Asia, where, through China's efforts, important regional pacts have been made - China-ASEAN Free Trade Area, ASEAN + Three, Northeast Asia and East Asia Free Trade

---

<sup>1</sup> Zbigniew Brzezinski; *America si lumea* , (editura Antenet revolution, 2005), p55.



Area -Asian Free Trade. The latter, in a shameless vision, could be the basis of some regional security arrangements.<sup>2</sup>

On the other hand, the Japanese, in their turn, created self-centred trade pacts as a counterbalance to China's initiatives, obviously aiming at conquering regional supremacy. Fukuyama suggests that the US could, instead of the bilateral alliance system, constitute a regionally based multilateral organization structure that plays "a very valuable coordinating role in the event of an unexpected collapse of North Korea." There is no doubt that, at present, the regional security of North East Asia is focused on the energy interests of the states. The current rivalry of Japan and China originates from Siberian oil. Putin granted China the right to participate in the development of the oil fields in Siberia. China is making efforts to import oil from Venezuela and Canada, as well as from the Persian Gulf. All these efforts show the Chinese people's express desire to strengthen their energy security and strengthen international cooperation, weakening the global dominance of the United States.

In the case of the extended Black Sea area, analysts see, through its propulsion and adjacent areas in the foreground of Euro-Atlantic strategic concerns, a requirement of the current global interest, a condition for the positive evolution of the political situation and a guarantee of regional stability and security and , from here, the world. The global role of the action of the numerous regional cooperation bodies existing in the area - see the Stability Pact for South East Europe, the Cooperation Process of the States of South East Europe, the Cooperation Initiative in South East Europe, the Conference of defence Ministers in Europe South-east, G7+2, which have the capacity to generate new initiatives, including in the field of regional security and defence, indicates a regional - global, bilateral relationship, supported by large institutions, such as UN, OSCE, NATO, EU etc.<sup>3</sup>

In the European part of the Euro-Atlantic area, determinants of regional security are currently the threats of global terrorism and the increased cross-border risks, which imply the promotion of the specific needs of the Caucasus, Central Asia and South-East Europe and the contribution of NATO member states to the new missions, actions that involve the extension and transformation of the concept of regional security through cooperation, adapting it to developments within the Alliance and from the global security plan. Regional security, which is practically a summation of the security of economic, ethnic, state and other entities in the area, is based on the involvement of states, based on the concept of "common regional problems - solutions through regional cooperation", in combating risks and threats. current ones generated by the process of globalization. An objective look at the relationship between regional security and global security highlights the existence, between the two terms of the process, of a real congruence and complementarity, materialized by a continuous complement and mutual support, the only one capable of leading to the establishment and maintenance of an authentic climate of peace. and zonal, continental and international stability. Of course, in order to deal with the multiple problems of the current security environment, regional and global policies in the field must be harmonized, removing any contradiction or non-involvement, against the background of the broad institutionalized and regularized nature of contemporary military and political globalization.

---

<sup>2</sup> Francis FUKUYAMA, Momentul neoconservator, The National Interest nr. 76, Summer 2004, traducere de Maria Bercea, în Revista 22, nr. 759 din 22-29 sept. 2004, [www.revista22.ro/html/index.php?nr=2004-09-22&art=1156](http://www.revista22.ro/html/index.php?nr=2004-09-22&art=1156)

<sup>3</sup> Nicolae FILIPESCU, Conductele și geopolitica, Revista 22, nr. 778 din 4-11 febr. 2005, [www.revista22.ro/html/index.php?art=1488&nr=2005-02-04](http://www.revista22.ro/html/index.php?art=1488&nr=2005-02-04)

As a consequence of globalization, numerous transnational developments and processes have a significant impact on national security. In addition to stimulating economic growth and opening up societies, recent issues pointed out by specialists highlight some disadvantages of the globalization process, which may lead to destabilization of some states, alienation of ancestral customs, vulnerability of entire regions to spontaneous fluctuations in the world economy. The positive influence of globalization on the democratic community, which includes 30 percent of the world's population, has 70 percent of the wealth, which guarantees and stimulates its freedom and prosperity, stability and security. In opposition to this, however, the domain analysts perceive, as a negative element of globalization, the situation of the instability arc that stretches from the Middle East to the Asian coast. The area is marked by problems of great gravity, such as poverty, inefficiency of government, power imbalance, high unemployment, extremist Islamic fundamentalism and, more importantly, lack of security. The main dangers of today's world - terrorism, tyranny, perverted governments, proliferation of weapons of mass destruction, ethnic tensions, government failures, resource scarcity, geopolitical rivalries, drug trafficking and organized crime - find here a fertile ground for affirmation.

# STUDY ON THE POSSIBILITY OF IMPLEMENTING A RELIABILITY-BASED MAINTENANCE STRATEGY

Eduard Florentin NECULA  
“Nicolae Bălcescu” Land Forces Academy, Sibiu,  
necula.eduard96@gmail.com  
Scientific Coordinator: COL Assoc.Prof.Eng. Ioan VIRCA, PhD

**Abstract:** *Maintenance is a study discipline that is part of the science called the rotech (theros-taking care) and according to military regulations, is a component of troop logistics. Maintenance specialists define maintenance activities as an assembly of "all technical and organizational measures (necessary), carried out in order to maintain or restore a product in the state necessary to perform the function specified". In view of the studies carried out on the reliability of military equipment, it has been found that due to the operation as well as the enemy's actions it is obvious that malfunctions will occur, which makes it necessary to apply maintenance of a type of planned activities with the aim of eliminating malfunctions. Thus, the field of maintenance has a very important role in the military organization and due to the rapid development of the technique it has appeared more and more in the attention of specialists*

**Keywords:** maintenance, organization, reliability, strategy, logistics.

## **1. Interpretation of maintenance activities based on reliability**

The main purpose of the reliability-based maintenance strategy is to identify exactly the main parts or subassemblies of the vehicles that are prone to malfunctions and to set the date on which maintenance and repair activities will be performed using all the maintenance resources for their execution. The date on which the maintenance activities are established takes into account the values of the diagnostic parameters on component structures. The diagnostic parameters cannot fully provide concrete information but are sufficient to direct the activities to the defective part or component. Such parameters are specific to the phenomena that occur along with the fundamental working processes such as: thermal or chemical changes, vibrations, pressures, different noises.

Although there is no diagnostic equipment on components, the specialists in the field have theorized effective management methods that help to find those critical points that can affect the good functioning of the systems and to establish the periods in which interventions are made, as well as to elaborate plans designed to reduce the consequences. failure of assemblies or subassemblies.

These methods are:

- analysis of failure mode, effect and criticality (AMDEC);
- the failure tree;
- WALL method;
- statistical control of the operation of the machines, etc.

At the same time, in order to apply the maintenance strategy based on reliability, in the next step the states are identified in which some assemblies or components, functioning, show signs of a malfunction. Here the defects are hierarchized, they are divided into functional defects and potential defects. The potential defect requires the existence of an identifiable physical factor, which represents an imminent functional defect. Thus, the basic principle of maintenance based on operational reliability is the identification of signs that allow the degradation limit to be set in order to allow the system to be fully exploited without encountering functional defects. In the following, a SWOT analysis of the implications of implementing the reliability-based maintenance system within the specialized military logistic structures is displayed.

<b>SWOT analysis</b>	
<b>Strong points</b>	<b>Weaknesses</b>
<ul style="list-style-type: none"> <li>- Can reduce costs maintenance, if applied to a large number of technical systems;</li> <li>- Provides accurate information with regarding the parameters of the parts and subassemblies;</li> <li>- Ensures maintenance operability of technical systems.</li> </ul>	<ul style="list-style-type: none"> <li>- Material and material barriers financially in the implementation of the strategy;</li> <li>- Lack of specialized training a staff in the use of computerized diagnostic technologies;</li> <li>- Deficiencies regarding legislation and regulatory rules.</li> </ul>
<b>Opportunities</b>	<b>Threats</b>
<ul style="list-style-type: none"> <li>- Allows the development of other strategies maintenance: orientation of investments and diversification of activities carried out;</li> <li>- Optimizes software programs maintenance;</li> <li>- Encourages development personnel skills in diversified activities (in theaters of operations, in specific missions, etc.).</li> </ul>	<ul style="list-style-type: none"> <li>-Insufficient material resources and funds allocated for the modernization of the equipment and for the specialized training of the personnel;</li> <li>- Restructuring of structures military from the point of view of the personnel, as well as of the logistical base;</li> <li>- The salary offer from outside military system.</li> </ul>

The SWOT analysis presented above presents the details that need to be considered in order to implement the strategy within the military structures.

It can be concluded by saying that in order to apply the maintenance strategy based on operational reliability, we must correlate between preventive, easy to apply and sufficiently effective maintenance models to help us discover early any critical points in the operation of military equipment. .

The critical points in the operation of the component elements and the assemblies of the important systems that ensure the good operation and a high level of operability for the military vehicles are:

- the engine / energy aggregate;
- transmission;
- the steering mechanism;
- propulsion system;
- the braking system.

The enumeration is not complete because they are only a part of the components of a military vehicle only that they are the basic elements that ensure the functioning of any vehicle. In the following, an attempt is made to present a case study that includes a model of the practical application of the new management methods, which is based on the maintenance

characteristics based on the operational reliability that helps to increase the operational reliability of the subassemblies of the military vehicles in use.

## **2. Possibilities for maintenance of military equipment maintenance**

The notions of reliability and safety in operation have emerged and accentuate the concern for finding mathematical models and calculation methods to obtain the most accurate forecasts regarding the behavior, for a certain period of time, of the subassemblies and assemblies under conditions of known exploitation. The reliability of the operation of a system can be assessed qualitatively by its ability to operate without fail for a certain period of time and under given operating conditions. From a quantitative point of view, the reliability will be appreciated by the probability that a technical system under study will perform the specified functions, with the established performances, for a defined period and under known operating conditions. At the level of the Ministry of National Defense, there are concerns about applying reliability systems, in the near future, the maintenance strategy based on reliability, as the strategy currently used by NATO member countries and leading to the efficiency of the maintenance system. This strategy takes into account the objectives of working and allocating the financial, technical and human resources specific to the category of operational reliability, as being "determined on the basis of the processing of the data obtained from the operation, that is, based on the follow-up in operation of several identical units, on a determined period of time".

Depending on the method used to calculate the reliability of the technical systems, the following categories of reliability are listed:

- Estimated reliability;
- Extrapolar reliability;
- Preliminary reliability;
- Technical reliability;
- Operational reliability.

The category of operational reliability is of interest in the study and implementation of the maintenance strategy based on reliability, and the researches in this direction are correlated with the principles of the integrated logistics system (SLI) concept, which provide the operational costs of ensuring the maintenance activity throughout the life cycle of the product (LCC- life cycle cost). In the real variant of financial assurance corresponding to the maintenance of the technical systems, from the funds allocated for performing high-complexity repairs (planned at large rolling intervals) and for technical revisions (planned at a relatively low number of years compared to the non-performed rolling). part could be directed towards investments in infrastructure and technology needed for reliability-based maintenance.

This strategy with efficiently dimensioned infrastructure (high maintenance formations, with high mobility required to perform the work in regional units subordinated to a financial resources coordinator), having available theoretical tools for analyzing and researching the quality of the maintenance process, will follow the identification of the essential objectives of the maintenance process preventive maintenance:

- detection and correction of early defects;
- reducing the probability of component failure;
- detection of hidden defects that have occurred;
- increasing the profitability of the maintenance program.

The increasingly complex construction of the current technical systems and their use on the battlefield, requires the use of diagnostic equipment and high-performance software, with a high degree of data access and interpretation of results, which requires the maintenance staff an extremely rigorous specialization.

Therefore, preventive maintenance needs to be supported in practice by a reliability-based strategy.

### 3. Methods to demonstrate the reliability of the systems

Maintenance strategy based on operational reliability will gradually reduce the probability of interruption of technical systems functioning and will decrease the number of unforeseen repairs, over time, being able to converge to the direct objectives of the total productive maintenance strategy:

- 0 accidental stops of the technical system;
- 0 accidents at work.

$$\text{Relation calculation of reliability: } R(t) = 1 - F(t) \quad (1)$$

R (t): The reliability function of the system, represents the probability that the system is in working condition at time t, operating under specified conditions;

F (t): The probability that the system will fail over time (o, t). The function of failure or unreliability of the system has the function of distribution:

$$F(t) = P(T < t), t \geq 0. \quad (2)$$

Reliability is expressed by a probability and has a value between 0 and 1. Being a probability cannot be measured directly as is the case with other physical quantities, but is determined on the basis of mathematical statistics methods and probability theory.

### 4. Conclusion:

Reliability forecasts allow the maintenance load to be evaluated in the event of a failure and the volume of spare parts that should be provided to make the unexpected failures in an equipment park. At the same time, the forecasts indicate the components that record upward degradation and impose a systematic replacement, which allows indicating the scheduled maintenance tasks. The effects of the maintenance strategy based on operational reliability will have beneficial consequences on the technical and economic indicators of the maintenance, as explained in the calculation relationships demonstrated above, but special attention requires its imprinting through financial, material and human support.

### REFERENCES

- [1] Bandrabur, C., Burlacu, G., Dăneț, N. and Duminică, T., *Fiabilitatea, mentenabilitatea și disponibilitatea sistemelor tehnice*, (București: Editura Matrix Rom), 2011.
- [2] Bayer, M., *Fiabilitatea și mentenabilitatea sistemelor*, (București: Editura Bren), 1999.

### BIBLIOGRAPHY

- Bayer, M., *Fiabilitatea și mentenabilitatea sistemelor*, București: Editura Bren, 1999.  
Bontaș, S., Filipoiu, A., and Târcolea, C., *Tehnici actuale în teoria fiabilității*, (București: Editura Științifică și enciclopedică), 1989.

# THE INFLUENCE OF ELECTROMAGNETIC RADIATION EMITTED BY MILITARY TRANSCEIVERS ON OPERATORS

Maria-Bianca PĂTRAN

“Nicolae Bălcescu” Land Forces Academy, Sibiu

patranmaria\_97@yahoo.ro

Scientific coordinator: Prof.Eng. Simona MICLEAȘ, PhD

**Abstract:** *The times in which we live are characterized by an exponential increasing sources of The Electromagnetic Field (EMF). It is coming from telecommunication, medical equipmant and many others apparatus. Other domain which is developed from this point of view is military domain. I am going to present in this report what i know about radio station functioning, use exposure and effects on human health, especially on the head. At the beginning I studied the near field manifestation of radio station, using an electromagnetic field sensor conected to a spectrum analyzer. I performed the mesurement verically using different power levels. After I obtained a set of values of the intensity of the magnetic and electric field, I followed the evolution of SAR, depending on frequency and the power used.*

**Keywords:**electromagnetic field, exposure, SAR.

## 1. Introduction

In the last period of time, there has been a substantial increasing of radio equipment, which has led to several studies concerning the impact of the equipment on human health. As they are used for a long period of time, adverse effects have been reported among the stuff. Regardless of the professional environment, the man is constantly interacting with the radio sources, the difference being the intensity and the duration of the exposure. Given the fact that the technologies in the military field are widely known and they are part of the equipping of all the armed forces of the states around the world, an action of research of the exposure level of the personnel who use these technologies is necessary. Although the effects of radiation are only visible after a long period of time, they manifest themselves through headaches, psychological disorder and, in the worst case, can even reach cancer. Thus, it is necessary for the population to have an education in this regard and to know the risks they are exposeddaily.

As the object of study of this article concerns the time-varying fields, waves are studied at the moment of detachment from the generating source. The influence of the radiation depending on the field area in which they are located.

The radiation field was divided as follows (Figure 1):

- The region of the reactive near field;
- The region of the radiative near field;
- The region of the far field.

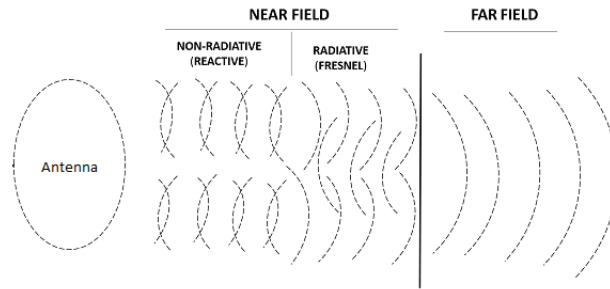

Figure 1-Electromagnetic field divided by areas

## 2. Materials and methods

To study the influence of radiation emitted by military radio sources, I used the following devices: the radio station Harris 7800V-HH, electric and magnetic field sensors and a spectrum analyzer. Harris 7800V-HH radio station (Figure 2) belongs to the category of portable radio handsets of the Falcon III family, used in the military field in various actions. It has a various facilities such as: voice communications (clear and secure), data transfer, automatic position reporting (GPS).



Figure 2-Harris 7800V-HH radio station

To determinate the distribution of electromagnetic radiation around the station, I used two of the sensors of the E&H Near Field complete, namely the 12 mm electric and magnetic field sensor. These are illustrated in the figure below (Figure 3) where the electric field sensor can be distinguished on the left side and the magnetic field sensor on the right side.



Figure 3-Electic and magnetic field sensors

Another device used is the Rohde & Schwarz FSH3 spectral analyzer (Figure 4). Due to the fact that it offers the possibility of field use quickly and provides accurate results, it is one of the most used analyzers. It is a device that offers the possibility of receiving signals from the 100 KHz- 3 GHz band. At the same time, it allows the analysis of the parametres of the received signals.





Figure 4-Spectral analyzer

### 3. Measurements, results and discussions

In the study I realised on the HARRIS 7800V-HH military radio station, I considered three directions for measuring electrical and magnetic components. The measurements were made with the help of the electric and magnetic field sensors and the spectral analyzer, previously presented. As can be seen from figure 5, measurements of the electromagnetic field were performed vertically, on a distance of 56 cm ( from the base of the station to the top of the antenna), from 2 to 2 cm. The station was positioned at a distance of 10 cm from the panel which is divided into three axes, corresponding to the ends and center of the station. I chose to use a single frequency, namely the 72.35 MHz frequency, using the station's transmitting power as a variable parameter. The three power levels considered during the process were  $P_1=0.25$  W,  $P_2=2$  W,  $P_3=10$  W.



Figure 5-Electromagnetic field measurement around the Harris 7800v-HH station

As can be seen from figure 6, the highest values of the electric fields intensity are recorded in the upper part of the antenna, with a maximum level of 528 V/m.

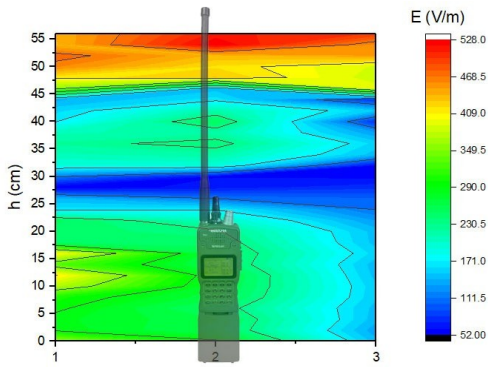

Figure 6-Electric field intensity distribution

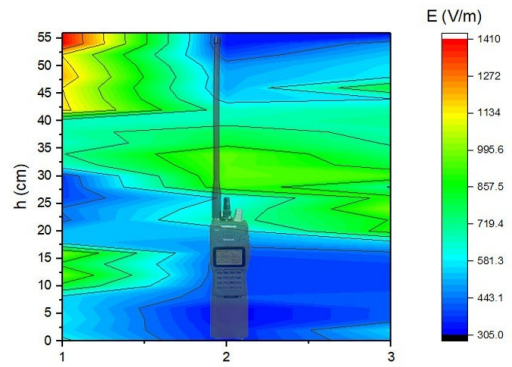

Figure 7-Electric field intensity distribution at  $P=0.25$  W  
 $P=2$  W

At an emission power of 2W, the intensity of the electric field has much higher values, but the distribution is no longer a uniform one in the upper part, but one concentrated in the upper left. Using the maximum emission power level, with a value of 10W, we can observe that the highest values recorded of the electric field intensity are also found in the upper end of the antenna, but this time being concentrated in the a point manner.

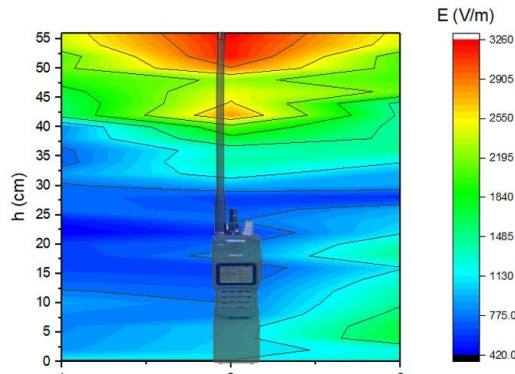

Figure 8-Electric field intensity distribution at  $P=10$  W

Performing an analysis on the intensity of the magnetic field at the lowest emission power of the station (0.25W), it can be observed (figure 9) that the highest values are found in the upper part of the station, in the antenna area. Reporting at the level of the station without antenna, in the left region, in the side with the emission antenna are recorded higher values compared on the other two axes on which the measurements were made. As the value of the power used increases, the intensity levels of the magnetic field acquire a layered, stratified appearance. At the base of the station and towards the tip of antenna can be seen a similarity of the distribution of the intensity of the magnetic field being approximately in the mirror.

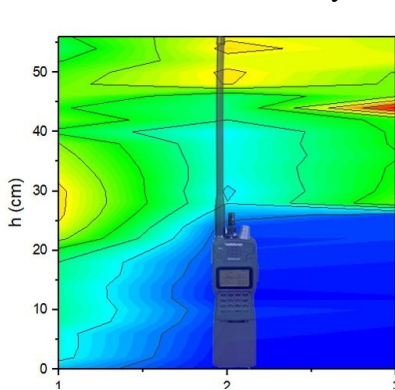

Figure 9-Magnetic field intensity distribution at  $P=0.25$  W

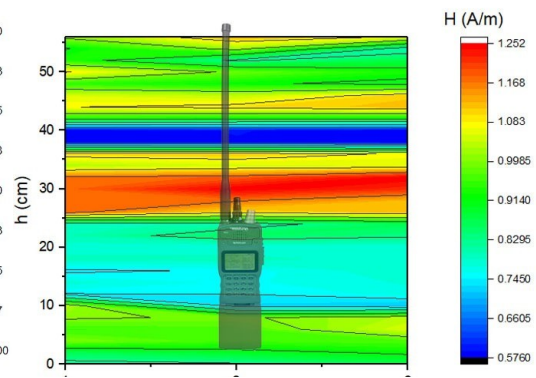

Figure 10-Magnetic field intensity distribution at  $P=2$  W

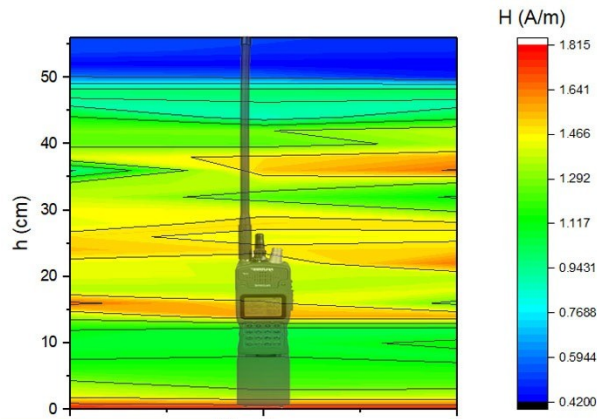

Figure 11-Magnetic field intensity distribution at P=10 W

Going forward, I chose to estimate the SAR (Specific Absorption Rate) values recorded for the three powers. The electromagnetic wave, passing from one environment to another (in this case from the air in the tissue-dry skin), undergoes some modifications, including attenuation. I studied the values of SAR at the skin level because it is the organ with the largest coverage area at the head level, not necessarily because it is the most sensitive and vulnerable to electromagnetic waves, using formula:  $SAR (W/kg) = \frac{\sigma}{\rho} * E^2$ , where  $\sigma$  is the conductivity of the material and  $\rho$  is the mass density. In this case,  $\sigma=0.45 S/m$  and  $\rho=1109 kg/m^3$ .

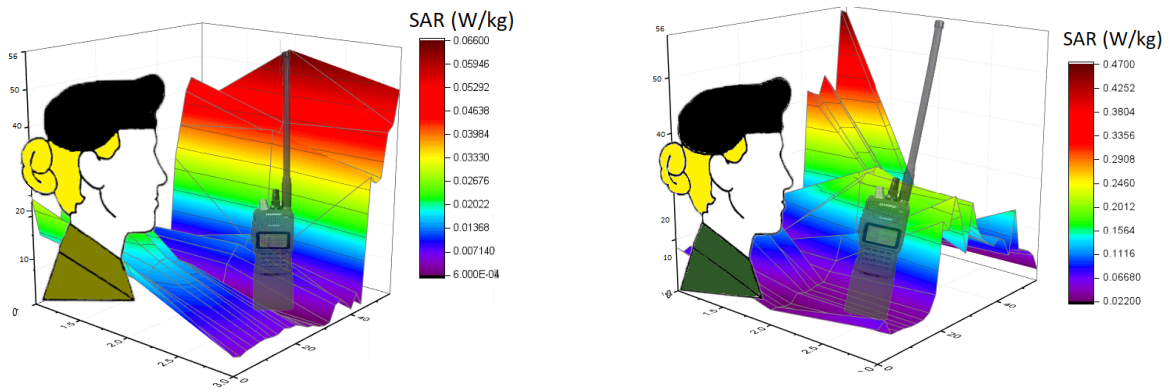

Figure 12-SAR at P=0.25 W Figure 13- SAR at P=2 W

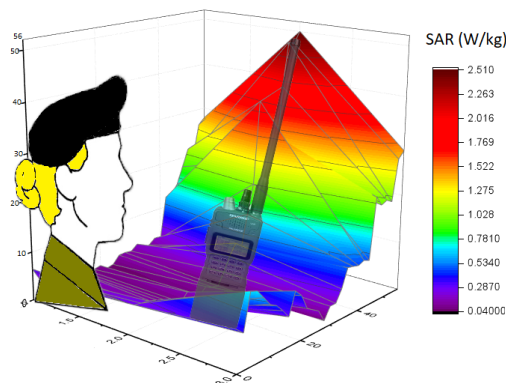

Figure 14- SAR at P=10 W

As can be seen in the three images with the distribution of SAR depending on the areas, at P=0.25 W and P=10 W, the peak values are found at the upper end of the antenna, which generates more pronounced effects in the area of nose and of eyes. At the average power, P=2 W, the distribution is concentrated on the left side, with large values in the same area of

the antenna. However, do not forget that the distance I worked during the experiment is 10 cm, but a operator can use the radio station much closer to the head and front, which would lead to a much higher level of radiance.

## Conclusion

An important aspect as a result of the measurements made is the way in which the SAR values increase with the increase of the emission power of the radio station, given that the frequency is an invariable factor. It can be observed that its distribution is similar regardless of the power at which the station was set, in the sense that highest values are approximately in the area from the middle of the antenna. It should be remembered that, when we propose an evolution of the electromagnetic field, special measurements are required, made under certain conditions so as to limit action of disturbing factors on the measurements result. In the case of the experiments we have done, due to the fact that the connection wire between the sensor and the analyzer has not been screened, the recorded values are higher than the normal ones.

## REFERENCES

- [1][http://www.etsist.upm.es/estaticos/catedracoitt/web\\_salud\\_medioamb/equipos\\_medida/equipos\\_nuevos/manuales/manual%20FSH3\\_operacion\\_ingles.pdf](http://www.etsist.upm.es/estaticos/catedracoitt/web_salud_medioamb/equipos_medida/equipos_nuevos/manuales/manual%20FSH3_operacion_ingles.pdf)
- [2]<http://www.aaronia.com/products/antennas/Near-Field-Probe-Set-PBS2/>
- [3]<https://www.harris.com/sites/default/files/downloads/solutions/rf-7800v-hh-handheld-vhf-tactical-combat-net-radio.pdf>

## BIBLIOGRAPHY

Carl H. Durney, Habib Massoudi, Magdy F. Iskander, *Radiofrequency Radiation Dosimetry Handbook (fourth edition)*

Cynthia Fures, Douglas A. Christensen, Carl H. Durney, *Basic Introduction to Bioelectromagnetics, CRC Press, 2009.*

A. Nicolaide, *Electromagnetics-General theory of the electromagnetic field classical and relativistic approaches*, Braşov, Editura Transilvania University Press, 2012.

# PREDICTIVE MAINTENANCE - THE FUTURE OF MAINTENANCE

Constantin Cosmin PETRACHE

“Nicolae Bălcescu” Land Forces Academy, Sibiu, Romania

bboy\_coma@yahoo.com

Scientific coordinator: COL Assoc.Prof.Eng. Ioan VIRCA, PhD

**Abstract:** *Predictive maintenance (Pdm) represent a concept used in order to optimise the maintenance plans based on the prediction of equipment failures using data-driven procedures. For the predictive maintenance system it is necessary to understand and also anticipate the equipment damages, to identify a tool able of evaluating the identified deterioration level, to analyse the provided information in terms of acting when an unacceptable level of damage has been detected. The increasingly complex construction of equipment, as well as their use in a wide range of activities, requires the use of diagnose equipment and also permanent software with a high degree of complexity.*

*Maintenance focused on reliability is a new innovative concept that is based on knowing the real state of equipment or its subsystems, researching probable failure types and taking predictive measures to eliminate the causes leading to failure. Quality maintenance performed at the right time delays or eliminates unexpected damages. The efficiency of the maintenance activity manifests itself over time, so it is necessary to promote a modern maintenance activity and a coherent strategy in this environment.*

**Keywords:** maintenance, equipment, reliability, damage, software.

Maintenance is one of the functional areas of logistics and includes all the actions taken to maintain and / or restore the equipment to the specific operating characteristics.

The main purpose of maintenance process is to reduce costs, develop a production strategy based on efficiency concept and the quality of products, and to provide production continuity and also personnel safety in order to create a useful life climate.

From past to present, the modern engineering system develop a various maintenance methods in order to provide equipment the opportunity to be fully operational all the time, maintenance types like maintenance and repair, run to failure (when a breakdown occurs), preventive maintenance associated with predetermined maintenance, predictive maintenance (monitor, identify and repair), proactive maintenance (define the problem, isolate it), reliability maintenance defined by a complex process of using proactive, predictive and predetermined maintenance methods. When we applied on of these maintenance methods, following factors need to be taken in consideration:

- Operating principles of the equipment;
- Type of equipment;
- Rate of the damages or failures;
- Operating and environmental of using the equipment;

- Specifications of the equipment.

According to these factors the predictive maintenance method offers the opportunity to apply an adequate and accurate maintenance before the breakdown occurs based on the information coming from the equipment via ECU (electronic control unit), so the necessary parts that need to be replaced can be planned for downtime, total costs being decreased.

In our days, the breakdown equipment components need to be replaced instead of repairing them. To establish the components that will be replaced is important to perform periodical analysis like vibration analysis, thermo graphic analysis, oil analysis and others.

Most of the maintenance procedures use a combined preventive and predictive maintenance, but in fact there are several differences between these maintenance types. While the preventive maintenance involves inspecting and performing the maintenance based on a schedule, the predictive maintenance demands the condition monitoring equipment components. The preventive maintenance program doesn't require the condition monitoring part so capital investment in technology and staff training is lower.

Being a complex activity, where the staff must be specialized on how to operate the diagnose tools and how to interpret data collected, the main disadvantage of predictive maintenance system is about the time spent for those activities.

Complex maintenance combines preventive maintenance with predictive maintenance. The verification of the parameters of the equipment using technical diagnose equipment, daily maintenance and the observations made by the operators, determines the "critical point" to apply corrective maintenance methods (replacement or repair of components, before their failure).

Maintenance focused on reliability is a new generation concept that is „based on knowing the real state of equipment or its subsystems, researching probable failure models and taking preventive measures to eliminate the causes leading to failure" [1]. Quality maintenance performed at the right time delays or eliminates unexpected faults.

Maintenance focused on reliability follows to provide full operation capability of the equipment and to maximize their availability, all at the lowest cost, provided by a quality maintenance performed on time.

Maintenance focused on reliability is a process that has proven to be useful since its application. When it is implemented correctly and using a qualified staff, this brings obvious positive results. The objectives of this type of maintenance may be different, but it has been used to “increase safety, reduce costs, improve availability, increase maintenance efficiency, improve environmental protection and achieve a longer service life for system components. "[2].

Other important features of the predictive maintenance system are:

- Takes into account the mode and mechanism of the defect and the operating environment;
- It measures characteristics according to the deterioration level;
- It is cheap and easy to make;
- Results can be easily interpreted without major differences of opinion.

To avoid breakdowns during production process, the checks of mechanical systems are essential in terms of reliability. Unplanned damages will conduct to production losses, so the anticipation of damages can be considered the future in maintenance process.

The value of predictive maintenance comes from a cost-saving and/ or time-saving approach, as maintenance is only performed when needed.

One of the most important factors for the predictive maintenance is the use and integration of the industrial internet of things. “The internet of things is perhaps the biggest piece of the predictive maintenance puzzle ...Internet of things translates physical actions from machines into digital signals using sensors such as temperature, vibration or

conductivity... Once the physical actions have been translated into digital signals via sensors, they are processed, aggregated and analysed” [3].

Each product has a certain life cycle and during it, it undergoes a process of constant usage, a process that usually comprises three periods, a period of time during which, it must intervene efficiently for the restoration performance for long-term use, as follows:

- Initial period, when the number of failures during the grinding are relatively large;
- Normal (useful) period of life, when the failures are reduced in number and can appears randomly;
- Final period, when the number of malfunctions due to the lot of usage increases sufficiently.

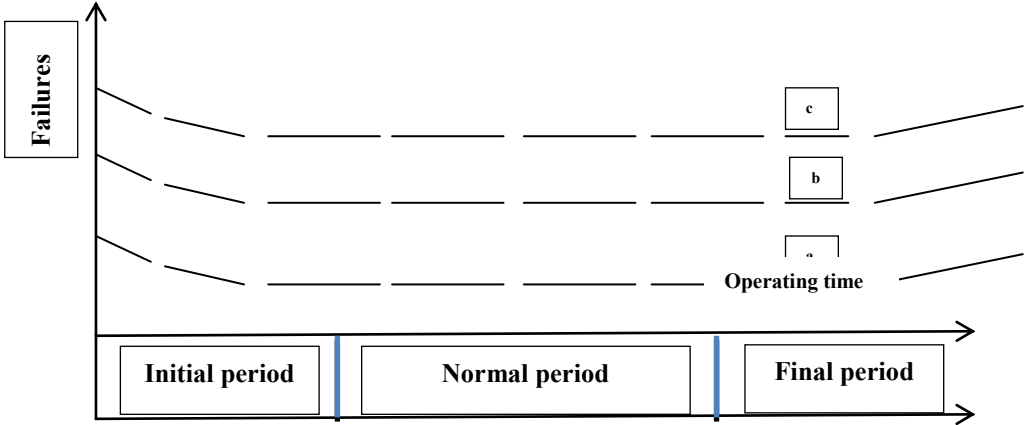

- a) Product manufactured and used in very good conditions;
- b) Product manufactured and used in normal conditions;
- c) Product manufactured and used under unusual conditions.

**Availability, reliability and efficiency of maintenance system**

When we talk about availability we understand that ability of the equipment to perform in optimal conditions the purpose for which it was designed. The indicator of efficiency is represented by the average of availability, which is based on statistical determinations specific to each type of equipment and can be expressed by using the relation:

$$A_A = \frac{\text{Availability time}}{\text{Availability time} + \text{Unavailability time}}$$

Related to a period of time the average of availability can be defined:

$$A_A = \frac{\text{MTBF}}{\text{MTBF} + \text{MTTR}}$$

MTBF = Mean time before failures  
 MTTR = Mean time to repair

The purpose is to obtain a maximum  $A_A$  according to a maximum **MTBF** and a minimum **MTTR**.

Related to this **MTBF** depends on:

- The quality of the equipment component elements;
- Maintenance policy;
- Operating mode.

**MTTR** is the result of progress in maintenance and repair technologies, correlated with the organization specific activities.

Reliability maintenance is a new complex maintenance system based on a combined proactive, predictive and predetermined maintenance type. Failures that can be discovered using analysis and determination methods are monitored in terms of predictive maintenance and what cannot be discovered using these methods will be monitored to apply preventive maintenance. The quality of the maintenance activities is tested using proactive maintenance methods.

Reliability can be defined as the possibility for a specific technical system or product to perform the function for which it was created, under given working conditions and time.

$$R_p = \frac{N_F}{TO}$$

$R_p$  = Reliability of product;

$N_F$  = Number of failures;

$TO$  = Operating time.

To obtain a maximum reliability, we need the smallest number of operating failures, obtained over a period of time that is desired to be as long as possible. This indicator is characteristic to each type of equipment, some companies even specifying its exact value under some operating conditions.

Maintenance process is carried out properly if defects/ failures are avoided as far as possible. This aspect is expressed according to the following relation:

$$E_M = \frac{C_F}{\sum_I * C_I}$$

$E_M$  = maintenance efficiency;

$C_F$  = failures costs;

$C_I$  = total cost related to the maintenance policies.

The indicator expresses the relationship between the cost of failures/ damages and the cost of maintenance, respectively the relationship between intervention and consequences.

Creating an efficient maintenance program requires understanding the failure mode, the mechanism of the defect occurrence and the rate of occurrence of the damage.

The changes that have occurred in the way of use the maintenance activity are based on a number of causes, technical, economic and even legislative. So, the increasing demands on vehicles in terms of environmental protection, from chemical and noise pollution, followed during the life of the product, to the recycling of equipment components, after the end of their life, have forced equipment performances to be stringent.

The efficiency of the maintenance activity manifests itself over time, and the continuous improvement of this activity is very important. For this, it is necessary to promote a modern maintenance activity and a coherent strategy in this area.

Predictive maintenance and preventive maintenance can be implemented in a way that minimizes the risks of malfunctions in order to obtain a completed life cycle of equipment.

The human resource has been and will remain an essential factor in carrying out the maintenance process, which means that in order to reach this development potential, in addition to the acquisition of modern systems of diagnosis, repair, etc., it is necessary to construct a plan, legislative framework that facilitates the creation of specialists as well as the specialization of the existing ones.

An efficient maintenance system requires an important financial support. It is known that one of the disadvantages of the current maintenance system is that of the high costs,



besides the one of the immobilization for long periods of time. As a result, the transition of the current system, to the new maintenance system based on predictive maintenance, leads to a decrease of the financial support.

To conclude, the maintenance process remains one of the essential functional areas of logistics with a major impact on the performance of the activities within the organizations due to the main purpose of maintaining / restoring the technical systems to the specific operating characteristics.

#### **REFERENCES**

- [1] Bayer, M., *Reliability and maintenance of systems*, (Bucharest, Bren Publishing House, 1999), 12;
- [2] Grosu D., *Diagnosis of military vehicles*, (Bucharest, course support, 2018), 12;
- [3] Coleman, *Predictive maintenance and the smart factory*, (Deloitte, 2017).

#### **BIBLIOGRAPHY**

- Bayer, M., *Reliability and maintenance of systems*, Bucharest, Bren Publishing House, 1999;
- Grosu D., *Diagnosis of military vehicles*, Bucharest, course support, 2018;
- Coleman, *Predictive maintenance and the smart factory*, Deloitte, 2017;
- Ulbert, Sebastian, *The difference between predictive maintenance and preventive maintenance*, Core systems, 2015;
- Wright, Jeremy, *How to leverage multiple predictive maintenance technologies*, Machinery Lubrication, accessed march 8, 2020.

# MAINTENANCE BASED ON RELIABILITY IN MILITARY TECHNICAL SYSTEMS

Ștefan-Cătălin PÎRVU

“Nicolae Bălcescu” Land Forces Academy, Sibiu

catalinpirvu1996@gmail.com

Scientific coordinator: COL Assoc.Prof.Eng. Nicolae MORO, PhD

**Abstract** :*Achieving high reliability is one of the major objectives in the development of the future combat system (FCS). The solution proposed to achieve this objective is a prognostic-based approach characterized by the ability to monitor the condition of the critical components for maintaining operability and to predict the future state of the system. In this paper, two approaches are analyzed and compared for obtaining and maintaining a high operational availability of military technical systems, namely: preventive maintenance and reliability of technical systems. It has been demonstrated that, the prognostic approach leads to improvement of the operational availability by anticipating the failure and reducing the administrative and logistical delays. As a positive aspect, according to the numerous cases in which this has been demonstrated, the prognostic capacity allows for intelligent maintenance, based on the replacement only of those parts whose life has reached the critical value, thus significantly reducing the costs required for repairs.*

**Keywords:** maintenance, reliability, military, equipment, system.

## **Introduction**

The military systems played an important role in the battle actions of the modern war, because the success or the failure of the mission depends on their performances but especially the life and the body integrity of those who serve them. Such a military technical system must include a well-developed unitary set, a set of necessary and compulsory quality features and a maintenance system adapted to the situation.

The means of combat used in the military actions in the theaters of operations or used in the country for training the forces are intensely demanded in the exploitation process, both physically and mechanically, demands that inevitably lead to increased wear and, implicitly, to the increase in number and the volume of defects. Maintaining the military technical systems in working order and at the qualitative parameters imposed by the requirements of the combat missions, periodically requires maintenance interventions, of longer or shorter duration which, as a whole, means non-operative technical systems[1]. The sum of the time intervals required for maintenance interventions constitutes the total immobilization time, during which the system is not available. Therefore, reducing the time of immobilization and increasing the quality of military technical systems are topical concerns of the specialists in the field.

### **The main purposes of maintenance**

Maintainability is the ability of a system, under given conditions of use, to be maintained or restored in the state of fulfilling its specified function when maintenance and repairs are performed under given conditions, with precise remediation procedures. Therefore, maintainability is that qualitative feature of a system, viewed from the point of view of maintenance and repairs.

NATO's AAP-6 Standardization Agency, in a Glossary of Terms and Definitions, offers a broad definition: "*Maintenance is the set of measures taken to put or reposition the material(system / equipment) in a specified state, until the end of its use, including control, testing, maintenance, modifications, repair, restoration, reconditioning, reuse, retrieval and retrieval of parts. of products to repair other damaged equipment and vehicles.*"[2]

Based on this definition, it appears that the main objectives on which maintenance is focused are the following:

- ensuring the functioning of the systems;
- ensuring system life through proper connections between its components;
- ensuring safety for human operators, environment and system itself;
- ensuring cost effectiveness in maintenance;
- enabling effective use of resources, energy and raw material.

### **Types of maintenance**

Depending on the state of the military technique, the moment of carrying out the works and their costs, maintenance can be preventive, corrective and complex.

*Preventive maintenance* includes checks, technical maintenance and repairs, planned at time intervals (miles run, miles traveled, hours worked, flight hours, shots fired, etc.) which, rigorously determined and executed, lead to greater operational availability, but also relatively high costs, the works carried out not always according to the real needs.

*The corrective maintenance* includes small, medium or large scale repairs, with an accidental character, whose purpose is to restore the damaged military technique to its functioning state, as a result of normal wear or participation in combat actions. It is more operationally inefficient and involves high costs.

*Complex maintenance* combines preventive maintenance with corrective maintenance. The verification of the parameters of the main equipment, units and systems, with the equipment of technical diagnosis, the daily maintenance and the observations made by the operators, determines the "critical point" at which it is necessary to intervene with works of corrective maintenance (replacement or repair of components, before their failure).

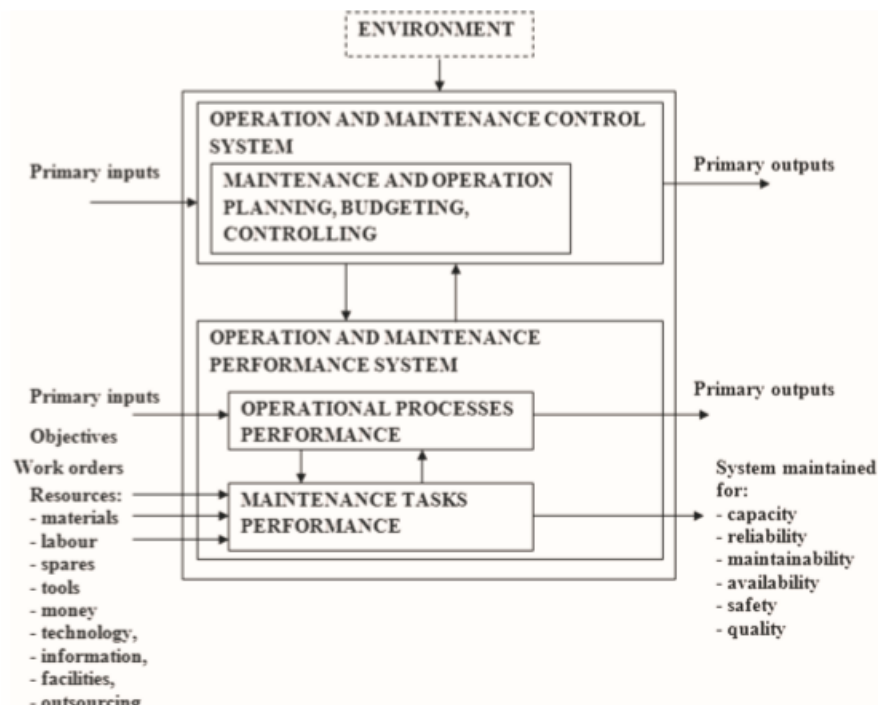

Fig.1.Maintenance of military technical systems- (source: *Technical system maintenance*, Werbińska-Wojciechowska ,Springer)

### Types of maintenance systems of technical systems

In essence, any maintenance system should indicate:

- when, where and by whom the technical interventions will be performed; what are the relations between the spheres of research-design, manufacture and use-maintenance;
- which is the network of maintenance units established on the principle of the respective system;
- how to distribute the entire volume of maintenance works on different categories of units that perform these works.

Those systems should fulfill the following requirements:

- ✓ to allow the programming of the technical interventions in terms of terms, volume of works and expenses;
- ✓ to avoid the unexpected removal of the technical systems from operation;
- ✓ to ensure the reduction of the immobilization time of the technical systems;
- ✓ not to allow the execution of unnecessary maintenance works, not claimed by the actual technical state of the technical systems.

Depending on the periodicity of the execution of the works, the maintenance systems are classified as follow:

- the maintenance system as needed;
- maintenance system with rigid planning;
- maintenance system with periodic controls;
- the planned preventive maintenance system.

The essential feature of *the maintenance system as needed* is that the technical interventions are performed only when the vehicle "falls", that is, it can no longer operate. The operating capacity of the car will be partially restored by the technical interventions carried out on the occasion of the repair of the current defects and the failures.

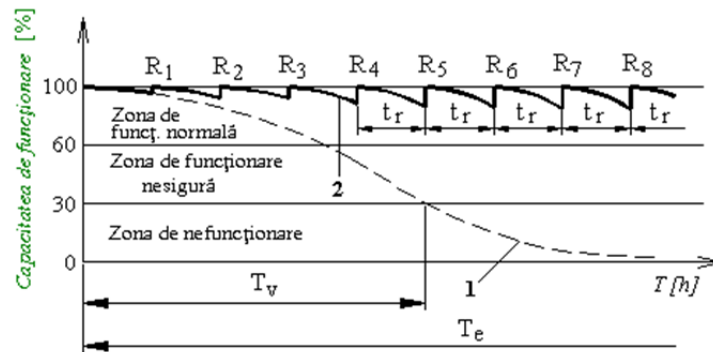

Fig.2.(the scheme of the execution of the technical interventions according to the system of maintenance with rigid planning)

According to this system, the technical interventions, which are of different complexity, are executed when the faults occur, that is, after the different operating periods  $t_1, t_2, t_3$ , etc. Through these technical interventions, only the technical state of the technical system is restored, as it is usually remedied only the defects that caused it to stop. The latent uses and defects of other components of the technical systems are not usually the object of the technical interventions executed as necessary. *The main advantage* of this system lies in its extreme simplicity: it does not require the establishment of precise deadlines for carrying out the technical interventions nor their planning.

*The disadvantages* of the system are:

- the unexpected removal from production of the technical systems, which puts under the sign of uncertainty the accomplishment of the production tasks;
- the impossibility of planning the technical interventions as volume of works, terms of execution and volume of expenses, because it is not known in advance the moment of the failure;
- the duration of the immobilization of the technical systems is high, because, not knowing the terms of execution of the technical interventions and their complexity, the necessary preparation cannot be carried out in advance;
- the operating capacity of the technical systems will be partially restored, as usually only the defects that cause them to be stopped are remedied, creating the premises of a chain failure;
- does not provide information on the degree of wear of the technical systems;
- does not ensure a guaranteed operation of the technical systems in use, because the reliability becomes random.

The system was applied in the beginning period of the machine, when the legalities of the behavior of the technical systems in use were not known and the gradation and succession of the technical interventions could not be established. Due to the disadvantages, this system is no longer used today as a basic system, but as a complement to modern systems.

*The system of maintenance with rigid planning* is diametrically opposed to the previous one and consists in the fact that the technical interventions are executed according to a prior planning, by which the terms and the volume of works for each one are established[3]. The technical systems are compulsorily removed from use after certain operating periods, and the technical interventions are executed regardless of the actual technical state.

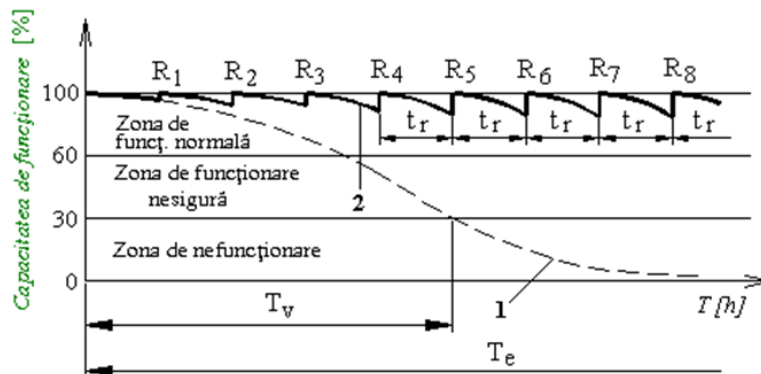

Fig.3. (the diagram of the execution of the technical interventions according to the system of maintenance with rigid planning)

According to this system the operating capacity of the technical systems is restored to the normal value through technical interventions of different degrees, executed at fixed terms established in advance. In this situation, the unexpected removal of the technical systems is excluded or, in the worst case, very rare, and the operating time of the technical systems increases to near the possible limit.

The advantages of the system are:

- accurate planning of the deadlines for removing the technical systems from use in order to perform the maintenance work;
- avoiding the unexpected removal of the technical systems from operation;
- reducing the specific immobilization time of the technical systems for the execution of the maintenance works;
- early preparation of the production;
- ensures an adequate level of reliability and operability between two successive technical interventions.

The disadvantages of the system are:

- the technical intervention is not carried out depending on the degree of actual wear, and there is the possibility of replacing some subassemblies that may still work;
- unjustified increase in the volume of works, the consumption of spare parts and materials and the expenses for maintenance works;
- increase the total time of immobilization of cars.

*The planned preventive maintenance system* can be taken care of itself and a mixed system includes advantageous parts of the previous systems, thus becoming particularly efficient. With regard to the systems, the car manufacturer stable for each car advice, is in fact scientific the result of the tracking in the conditions of use of the cars and of the base of computers for forecasting the wear of the markets, the technical nomenclature and the intervention cycle, their periodicity and the volume of mandatory works for each technical intervention.

The following figure shows schematically the influence of preventive and corrective technical interventions on the technical state of a technical system in the case of the planned preventive maintenance system. As shown in the graph, preventive technical interventions are carried out following a rigid planning, current repairs are carried out as needed, and capital repairs are executed after an elastic planning, which includes the prior verification of the technical state.

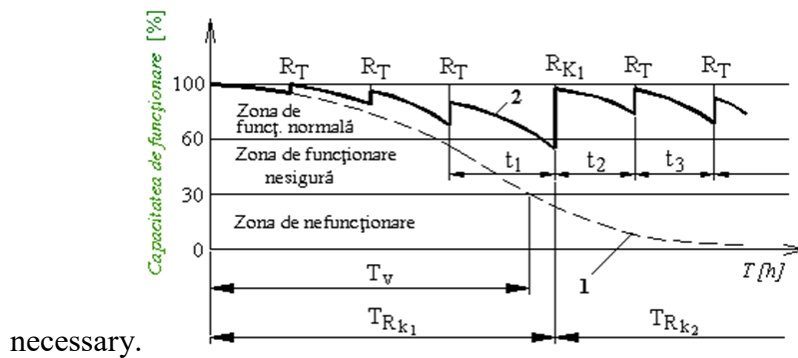

Fig.4.(the scheme of the execution of the technical interventions according to the planned preventive maintenance system)

The advantages of the system are:

- the scientific management, on a plan basis, of the maintenance activity;
- avoiding the unexpected departure of the technical systems;
- increasing the effective life of the cars;
- the complete execution of the preventive technical interventions foreseen, at established deadlines and in the prescribed volume.

The disadvantages of the system are:

- there is a very high percentage of cases in which the maintenance works that are performed prove to be useless, failing to detect the faults or the premises of faults, the checked units being in perfect working condition;
- making unnecessary expenses, especially determined by the labor used to carry out all the prescribed works, and in stock there must be spare parts which may not be immediately necessary.

The system of maintenance with periodic controls is basically reduced to the periodic verification of the car park by a technical commission and to establish, on this occasion, the type of technical intervention, the volume of the workmanship, the quantity of spare parts and materials required, the preliminary cost of technical intervention and their deadlines. According to this system, the prior planning of the technical interventions is not done, but only of the data of the periodic controls.[4]

The advantages of the system are:

- avoiding the unexpected exit of the technical systems;
- reducing the volume of maintenance works;
- reducing the volume of spare parts and materials needed to perform the maintenance work;
- the reduction of the maneuver and the reduction of the expenses with the maintenance works.

As a disadvantage, it is mentioned that the application of this system does not stimulate the maintenance in good condition of the technical systems, because it is not ensured the long-term programming of the technical interventions and the normation of the operating periods between them. Due to these shortcomings, the applicability of the system has been continuously restricted and is currently being used within the planned preventive maintenance system.

### **Reliability of technical systems**

Reliability is the ability of a technical system to operate without fail within a predetermined period of time and under given conditions of use.[5] This definition qualitatively expresses the value of the reliability of the technical system.

The formulations are innumerable over time, but it should be noted that reliability generally expresses the measure of performance and has two basic characteristics:

- a) full performance of the functions for which the technical system was performed, under the conditions of use imposed;
- b) performing these functions for a pre-determined duration of use.

Reliability is also defined as the operational safety of the technical system throughout its life and is mainly concerned with finding the fault laws. As a result, research in the field of reliability is oriented towards the notion of failure. However, the moment of failure occurs depends on several random factors, so that the quantitative estimation of reliability is made based on probability theory.[6]

The reliability is designed and is monitored throughout the life of the technical systems, at all stages from conception to their removal. In the table no. 1, next to the life stages of a technical system are specified the different fields of interest and work constituted in established disciplines of study and analysis, interest presenting the discipline reliability.

In the design and construction of the various equipments it is necessary to ensure their operational safety; this condition has led to the use of certain safety factors in the design.

The reliability of the operation can be assessed qualitatively by the ability of a system to operate without fail over a certain period of time and under given operating conditions.

From a quantitative point of view, the reliability will be appreciated by the probability that the technical system under study will fulfill the specified functions, with the required performances, for a period and under known operating conditions.

Reliability has many applications in the technical field due to the special structural and functional complexity of the systems used and the need to ensure a high level of safety.

The application of the models regarding the reliability of the systems in the technical field, besides the possibility of estimating the continuity indicators in operation of a technical installation, also allows the choice of an optimal variant of the structure of the installation from the set of possible solutions, allowing to realize the indicators of continuity in operation desired with the minimum costs.[7]

## REFERENCES

- [1] Wallace Blischke, PrabhakarMurthy, *Reliability: Modelling, PredictionandOptimization*, (Willey, New York 2000) 58;
- [2] STAS 8174/1-1977, Reliability, Terminology;
- [3] Cătuneanu M. Vasile, Mihalache, *Bazeleteoretice ale fiabiliității*, (EdituraAcademiei, București, 1983) 29;
- [4] Ibidem, p. 31;
- [5] VăduvaIon, *Fiabilitateaprogramelor*, (EdituraUniversității din București, 2003);
- [6] ScrieciuLiviu, *Sisteme de mentenanță*, (Editura Universității Naționale de Apărare, București, 2007);
- [7] Iwona Paprocka, The model of maintenance planning and production scheduling for technical systems, 2018, 1-22.

## BIBLIOGRAPHY

- Wallace Blischke, PrabhakarMurthy, *Reliability: Modelling, PredictionandOptimization*, Willey, New York 2000;
- Cătuneanu M. Vasile, Mihalache, *Bazeleteoretice ale fiabiliității*, EdituraAcademiei, București, 198;
- ScrieciuLiviu, *Sisteme de mentenanță*, Editura Universității Naționale de Apărare, București, 2007;
- Văduva Ion, *Fiabilitateaprogramelor*, EdituraUniversității din București, 2003;



L 11 -Instrucțiuni privind mentenanța tehnicii și echipamentelor din înzestrarea Ministerului Apărării Naționale pe timp de pace, în situații de criză și la război, București, 2002;

Verzea Ion, Marc, G., Richet D., *Managementul activității de mentenanță*, Polirom, Iași, 1999

# SDR SYSTEM FOR IDENTIFYING FREQUENCIES IN THE FREQUENCY HOPPING SET

Andrei-Cătălin POPA

“Nicolae Bălcescu” Land Forces Academy, Sibiu

popa.andrei2k18@gmail.com

Scientific coordinator: Assist.Prof.Eng. Iulian BOULEANU, PhD

**Abstract:** *In recent years SDR (Software Defined Radio) technology has begun to attract attention in the military, generating new standards in military communications systems. This possibility of using a flexible architecture that uses universal circuits and that allows the digital signal processing has led the specialized industry beyond the third generation of communication systems. In this article I aimed to find a solution by creating an SDR system through which to identify the frequencies in the frequency jump set. An SDR receiver was created using the RTL2832 stick and GNU Radio Companion application. The introduction of SDR technology in the military field has provided the opportunity to create flexible communication systems, easily adaptable to various protocols and interoperable using multi-mode and multi-band services. The advantage that this technology offers is that it can efficiently manage and monitor the signal spectrum. This possibility of using a flexible architecture that uses universal circuits and that allows the digital signal processing has led the specialized industry beyond the third generation of communication systems.*

**Keywords:** SDR, receiver, multi-band services, spectrum, technology

## 1. Introduction

In order to be able to understand the importance and necessity, which led to the development of this technology both in the civilian and in the military environment. Software Defined Radio is a radio communications system, in which components that were initially implemented as hardware components (mixers, filters, amplifiers, modulators, detectors) are implemented through software on a personal computer or in an embedded system. Eric Blossom, the founder of Gnu Radio, says that SDR technology turns hardware problems into software problems because it is much easier to manage such a system. The system itself is based on the passage of hardware components through a computer that can process the signal. A simple SDR receiver consists of a computer on which to install a sound interface and a radio.

The opportunities offered by this technology consist in the fact that flexible radio equipment with a longer service life can be provided and can be used both in civil and military radio communications. SDR can also offer much more flexible and possibly cheaper terminals for end users. It is also important as a convenient base technology for future sensitive, adaptive and learning radio units, called cognitive radios. This technology presents many challenges, but one of them causes SDR evolution much slower than anticipated.

Because the radio frequency spectrum is an exhaustible resource, software Defined Radio has found solutions to effectively manage and monitor the radio frequency spectrum. With the help of applications installed on a hardware platform, spectrum management and management can be executed so that it can be used as efficiently as possible. Software Defined Radio has grown in the last two decades and has become a technology that can bring innovations and efficiency in the field of radio communications, offering maximum efficiency in the processing, monitoring and management of the radio frequency spectrum. In order to be ready for modern warfare, military communication on the battlefield must be interoperable, adaptable and fast.

Software defined radio (SDR) is the solution that makes it possible to communicate smoothly on the battlefield. The needs of military radio communications have evolved from basic communication, namely voice and data communication. The military now needs a communications system that uses several different frequencies and implements different protocols. SDR has evolved significantly over the years and is able to meet these specific needs. Furthermore, SDRs can be used not only for two-way communications but also for repeater communications, thus allowing different wireless devices to communicate with each other and provide secure wireless nodes. In times of conflict, military communications are significantly dependent on adaptability, clarity, interoperability, accuracy and speed. Deficiencies in any aspect of military commutes can have bad consequences. As a result, SDR technology has a significant influence on defense mechanisms because the device offers not only standard two-way communications, but also secure wireless nodes, so it engages multiple different devices simultaneously and offers a very low latency point for wireless links between points.

Currently, the defense industry is involved in monitoring and communication activities on several different frequencies (HF, UHF and VHF). It also works using several protocols (CDMA, GSM, LTE and WiFi). Traditional equipment gives military personnel the ability to adapt to one of their favorite frequencies and to support a single protocol. SDR offers a remarkable advantage, as those on the battlefield are able to monitor and communicate over a large part of the spectrum, while supporting more protocols. The weight to be carried by soldiers has always been a problem, as it can affect the movement of the military on the ground. With the help of Software Defined Radio, it has been possible to reduce the size, weight and power for those in the fight, thus becoming a device that replaces more radios. Field communications devices should be adaptable, clear, interoperable and fast to ensure seamless and efficient communication. From the Speakeasy system implemented in the years 1991-1995, working with frequencies from 2 MHz to 2 GHz, SDR technology has evolved remarkably today. A good example is the Perry Crimson SDR platform, which operates at 6 GHz with a frequency bandwidth of 1 Ghz in four independent chains (each chain offers 322 Mhz bandwidth).

SDR can provide a more efficient way to use the signal spectrum. The ultimate goal of SDR is the development of transport devices that provide access to a variety of wireless services. SDR has the ability to create portable stations that will make this dream come true. Many applications such as mobile services, web browsers, global positioning or video conferencing can be integrated into a single system. Although the high convergence of these types of systems is not so close at present, the concept of SDR brings with it this great potential and we will only have to follow its development.

The scattered spectrum is a way to transmit the signals in which a signal occupies a bandwidth that is larger than that of the signal, the frequency hopping can be a solution to achieve a transmission with scattered spectrum. In the frequency hopping technique, the frequency with which it is emitted and that of the receiver are set in such a way that they change synchronously, using a band wider than that of the signal, according to a pseudo-

random sequence. Frequency hopping is resistant to jamming or certain interferences, because if jamming is attempted, it is necessary for the enemy to jam the entire frequency range, but this is not feasible. The enemy has very low chances to take data from some transmissions because the frequency changes continuously, from several hundred jumps / second to several thousand jumps / second.

The main purpose of the frequency hopping technique is to eliminate interference. Interference protection is known as anti-jamming. This is one of the most widespread applications of communications using the spread spectrum. The receiver code decreases the signal and introduces it into the bandwidth of the initial message, but it spreads the interference taking into account the spreading ratio. Thus, the jamming ratio represents the increase of the useful signal / interference ratio. It should be noted that the scattered spectrum does not improve the SNR (signal / noise). Frequency hopping is one of the most widely used spectrum techniques in military communications. This technique consists in changing the carrier frequency at a certain time interval having broadband values after the pseudo-random sequence distributed by a pseudo-random code generator. By changing the frequency of the synthesizer, it produces a continuous jump from one value to another value. The frequency hopping technique can be used independently of jamming or there may be a possibility to avoid it by programming a set of frequencies or sectors within the band. With the help of the frequency hopping, jamming is avoided, thus obtaining the processing gain. The value of this gain is directly proportional to the jump speed and the number of frequencies used. Following experiments using the frequency hopping technique, it was observed that the value of the processing gain is higher when a higher number of frequencies are used to make the jump, so the processing gain does not necessarily depend on the speed of the code generator.

## **2. Materials and Methods**

In this article the author's main objective is to develop an application in the GRC (Gnu Radio Companion) that can receive signals from radio networks working in frequency hopping and to identify the value of these frequencies. The RTL 2832 is a device that can be easily used and is used to perform the spectral analysis of radio frequency signals through digital signal processing. This stick has a frequency range of 24 MHz to 1766 MHz. According to the specifications with which this device is presented, the sampling rate is 3.2 Msps, but so far the maximum tested rate is 2.56 Msps. Many software are available for RTL2832.

Most user-level packages are based on the librtlsdr library that comes as part of the basic rtl-sdr code. This database contains both the library itself and a number of command line tools such as `rtl_test`, `rtl_sdr`, `rtl_tcp` and `rtl_fm`. These command line tools use the library to test the existence of RTL2832 devices and perform basic data transfer functions to and from the device. Since most RTL2832 devices are USB-connected, the librtlsdr library depends on the libusb library to communicate with the device. At the user level, there are several options for interacting with the hardware. The rtl-sdr base code contains a basic FM receiver program that works from the command line. The `rtl_fm` program is a command line tool that can initialize RTL2832, assign a certain frequency, and transmit the received audio signal to a file or output pipe to command line audio players, such as `alsa aplay` or `sox play` commands. There is also the `rtl_sdr` program that will extract the raw I-Q data into a file for further basic analysis.

The operating principle of this system is based on the capture of the radio frequency signals that are in the 24MHz-1766MHz band by the system antenna. The signals are fed into the tuner using a radio frequency cable, which is then coupled to the RTL2832 with an SMA socket. The 820T2 tuner changes the frequency of the input signals and brings them to the base band. The RTL2832 converter samples the signal from the analyzed band, the sampling

rate is up to 2.5 Msps. The converter is capable of sampling at a rate of 3.2 Msps, but there is a risk of losing samples.

Following the processing of the samples, using the Fourier transform, information about the spectral components of the signal in the analyzed band is obtained. For the control of the system created by means of the RTL 2832 stick and antenna, GNU Radio is used, a program by which the digital processing of the signal received from the hardware system is performed. The block diagram is presented in Figure no. 1.

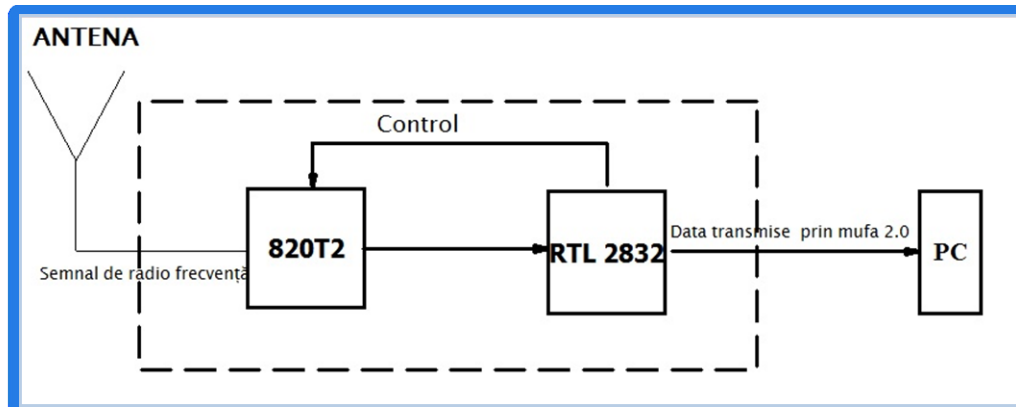

Figure no. 1: Block Diagram

After the measurements were made using the hariss 5800 V-MP station, the signals were stored in data type files which were later used in the application created using GNU radio. (figure no. 2)

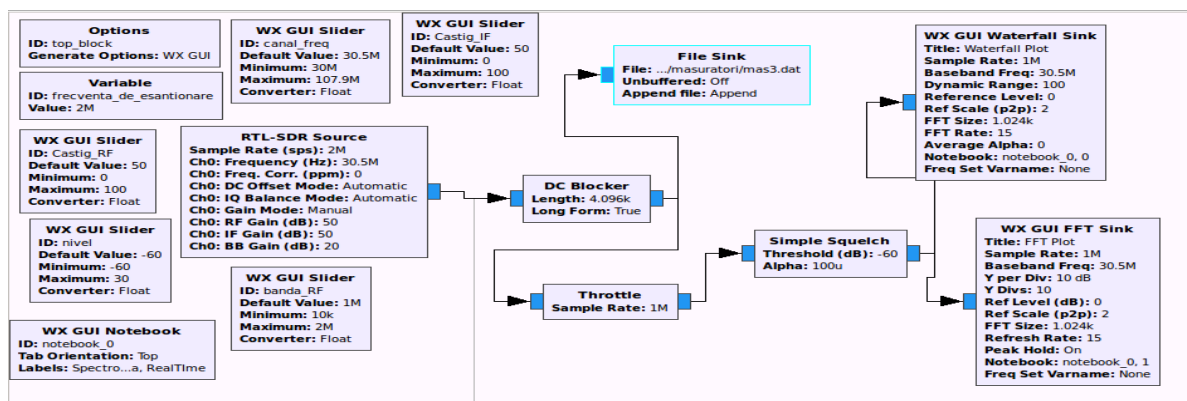

Figure no. 2: Application diagram in GNU Radio

This scheme was developed for the purpose of processing the signals in the band allowed by the RTL2832 stick. The stick band is between 24 MHz and 1766 MHz.

The application created has the following functions:

- Displays through the Fast Fourier Transform the spectrum of signals in the band of interest using a bandwidth of 2 MHz.
- The cascade graphic display is used to display the amplitude, frequency, and time with the amplitude represented as a color variation.
- It allows the selection of the band of interest by means of cursors;
- Saves the input data of the signals in a file. This file can be read in any programming environment that can read binary files.

### 3. Results and Discussions

To test the functionality of the GNU application, the Harris 5800V-MP radio station created two frequency jump sets, one with five frequencies and the other with ten frequencies. Thus, during the broadcast, the GNU application must capture the signal and save it for further processing in Matlab.

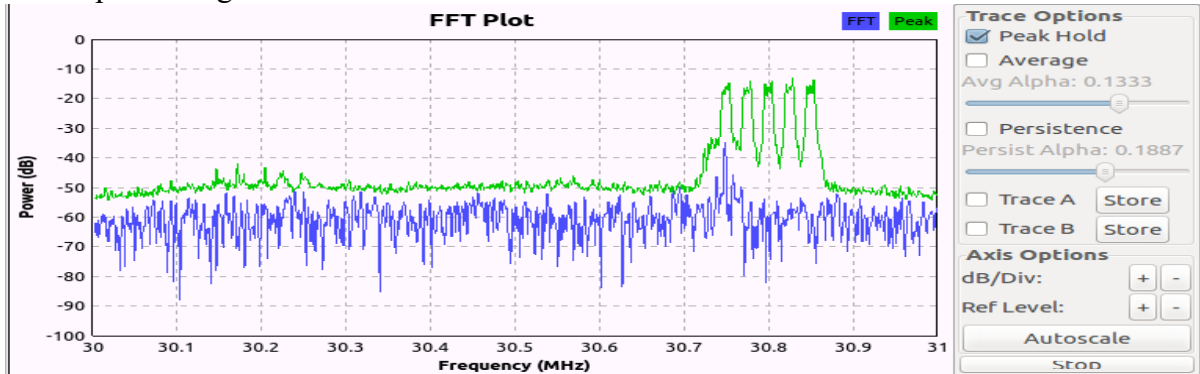

Figure no. 3: Spectrum visualization

The sampling rate was set to 2 Msp/s, the two gains, the intermediate frequency gain and the radio frequency gain, were set via the two sliders "Castig\_RF" and "Castig\_IF" to the value of 50 dB. (figure no. 3)

In figure 4, we can see in the right side of the FFT window, the five frequencies through which the frequency hop is performed. Thus, it can be seen that the system created using the RTL 2832U stick and the GNU application receives the broadcast signal from the Harris 5800V-MP radio station. To see the five samples, a second graphic display was made using the Waterfall Sink block.

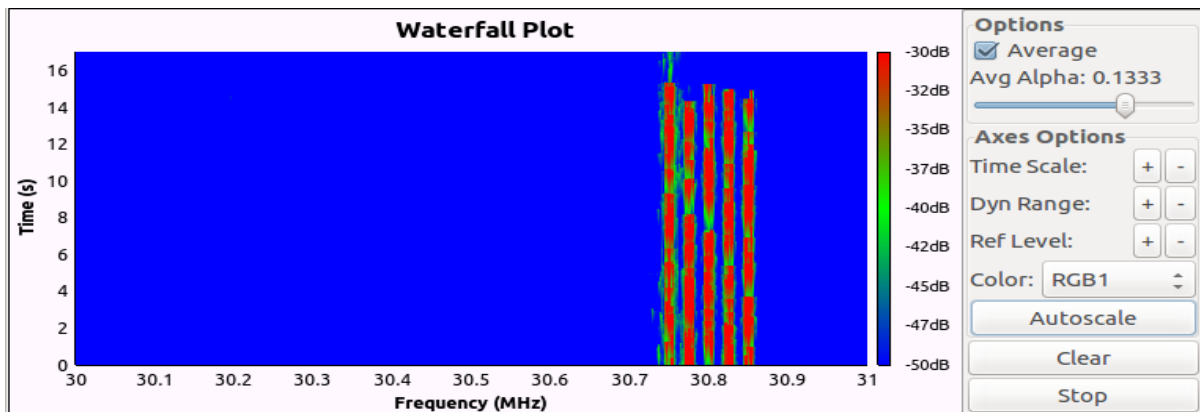

Figure no. 4: Spectrum through the Waterfall Sink block

A second set of hopping frequencies was used to verify that the application is reliable and receives the broadcast signal from the Harris 5800V-MP radio station. To perform this test, the same settings as the above test were approached. Sample rate set to 2Msp/s, squelch level to -60 dB and the two gains to 50 dB.(figure no. 5)

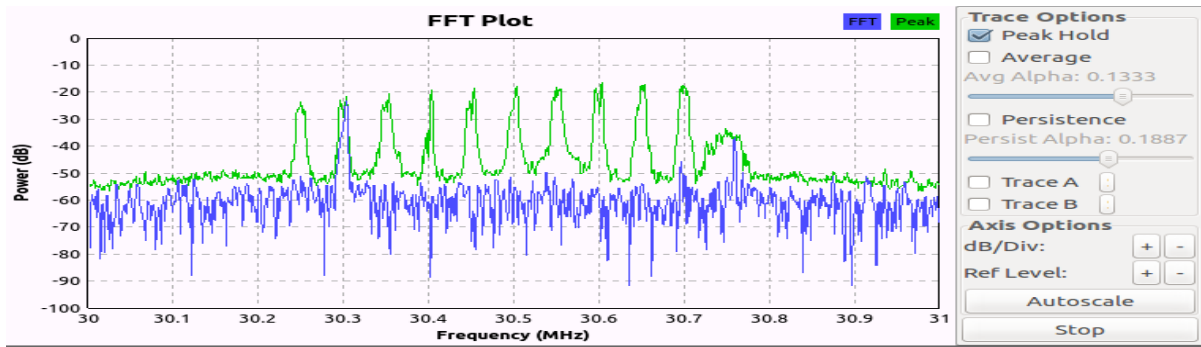

Figure no. 5: Visualization of the signal spectrum

The GNU application has managed to receive the signal emitted by the Harris 5800V-MP radio station, the signal spectrum in the figure above illustrates the ten frequencies, while also marking the peak value of the signal power at the time of transmission. To see the ten samples, a second graphic display was made using the Waterfall Sink block. Unlike the FFT spectrum of the signal, displaying the signal samples using the Waterfall Sink block, performs a signal analysis in the time and frequency domain, while the FFT spectrum represents a signal analysis based on the signal strength and frequency. (figure no. 6)

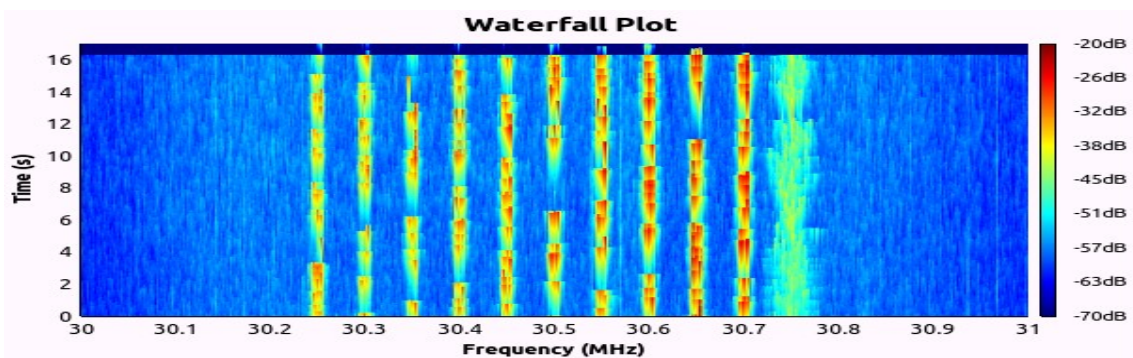

Figure no. 6: Spectrum through Waterfall Sink block

#### 4. Conclusions

SDR technology offers the military the ability to establish communication and information paths on the battlefield quickly and efficiently, without making it difficult for them to carry out missions due to the lack of interoperability, flexibility and adaptability of the equipment to the battlefield conditions. A new innovation offered by the SDR technology is to implement in a software application installed on a hardware platform the possibilities of modulation, spectrum visualization, signal demodulation without the need for bulky physical equipment. SDR can be defined as a communication device where the function of the transmitter and receiver can be modified by software, without making any physical change to the hardware. This is a huge evolution starting from other hardware based radio stations. These systems are made possible by the flexible development of a broadband tuner and filters along with programmable digital chips. In addition, the structure allows a single hardware platform that is used to access multiple frequencies using only software applications instead of the traditional hardware approach.

Military communications require high performance capabilities to communicate on different frequency bands and of course, the ability to communicate using different protocols (WiFi, 4G LTE, Bluetooth, proprietary protocol, etc.). SDR offers the advantage of using new technologies that appear through system upgrades without the need to change equipment. This

has resulted in overall cost savings for both hardware and training, effectively using available technology.

I have demonstrated that it's possible to create an SDR system that can be used to measure or intercept signals from a radio broadcast that uses frequency hop at almost any level. Obviously that the values we're not fully exactly because if you want the exact results of the frequency you will need an antenna that has a lot of power and does not have high losses. The application has a friendly gui interface with a lot of properties and a lot of tags were you can modify a lot of values to see the full spectrum.

## REFERENCES

- [1] P. K. Bondyopadhyay and G. Marconi, "The Father of Long Distance Radio Communication -An Engineer's Tribute", *Proceedings of the 25th European Microwave Conference*, vol. 2, pp. 879-885, 1995.
- [2] G. Youngblood, "A Software-Defined Radio for the Masses, Part 1", *QEX: A Forum for Communications Experimenters*, 2002.
- [3] R. J. Lackey and D. W. Upmal, "Speakeasy: the Military Software Radio", *IEEE Software Defined Radio: Basic Principles and Applications Communications Magazine*, vol. 33, pp. 56-61, 1995.
- [4] [https://www.researchgate.net/publication/220250216\\_Software\\_Defined\\_Radio\\_Challenges\\_and\\_Opportunities](https://www.researchgate.net/publication/220250216_Software_Defined_Radio_Challenges_and_Opportunities)
- [5] <http://mil-embedded.com/articles/software-defined-radio-key-seamless-effective-military-communication/>
- [6] <http://www.radio-electronics.com/info/rf-technology-design/superheterodyne-radio-receiver/block-diagram.php>
- [7] <http://www.radioamator.ro/articole/view.php?id=783>
- [8] <http://www.creeza.com/tehnologie/comunicatii/Software-Defined-Radio782.php>
- [9] [http://rfcec.com/RFCEC/Section-3%20-%20Fundamentals%20of%20RF%20Communication-Electronics/33%20-%20TRANSCEIVER/Transceiver%20-%20A%20Software%20Defined%20Radio%20What%20are%20the%20advantages%20\(By%20ARRL%20SDR%20Working%20Group\).pdf](http://rfcec.com/RFCEC/Section-3%20-%20Fundamentals%20of%20RF%20Communication-Electronics/33%20-%20TRANSCEIVER/Transceiver%20-%20A%20Software%20Defined%20Radio%20What%20are%20the%20advantages%20(By%20ARRL%20SDR%20Working%20Group).pdf)
- [10] <http://www.creeza.com/tehnologie/comunicatii/Software-Defined-Radio782.php>
- [11] <http://www.etsi.org/website/document/Workshop/SoftwareDefinedRadio/SDRworkshop1-7Chadwick-Zarlink.pdf>
- [12] [http://rfcec.com/RFCEC/Section-3%20-%20Fundamentals%20of%20RF%20Communication-Electronics/33%20-%20TRANSCEIVER/Transceiver%20-%20A%20Software%20Defined%20Radio%20What%20are%20the%20advantages%20\(By%20ARRL%20SDR%20Working%20Group\).](http://rfcec.com/RFCEC/Section-3%20-%20Fundamentals%20of%20RF%20Communication-Electronics/33%20-%20TRANSCEIVER/Transceiver%20-%20A%20Software%20Defined%20Radio%20What%20are%20the%20advantages%20(By%20ARRL%20SDR%20Working%20Group).)
- [13] <https://www.electronics-notes.com/articles/radio/sdr-software-defined-radio-receiver/sdr-basics.php>
- [14] Lt. ing. Marian UDROIU, Stația radio software – element al câmpului de luptă digital, [http://www.cissb.ro/Revista\\_comunicatiilor\\_informaticii\\_2011/cap19\\_STATIA.pdf](http://www.cissb.ro/Revista_comunicatiilor_informaticii_2011/cap19_STATIA.pdf)
- [15] <http://www.satelliteevolutiongroup.com/articles/Software-defined-radios-April17.pdf>
- [16] <http://lexus801.tripod.com/srtc/13.html>
- I. Bouleanu, *Curs Noțiuni generale privind saltul de frecvență*, Sibiu, 2007, p. 9.
- [17] <https://www.tutorialsworld.com/spread-spectrum/advantages-and-applications-of-ss-communications.htm>
- [18] <https://searchnetworking.techtarget.com/definition/frequency-hopping-spread-spectrum>



[19]

# EXPERIMENTAL DETERMINATION OF SECURITY PROBLEMS FOR CERTAIN SECURITY SYSTEMS OF SOME AUTOMOBILE AND IMPLEMENTATION OF SOME COUNTER IDEAS

Alexandru-Gabriel ROMANIUC  
“Nicolae Bălcescu” Land Forces Academy, Sibiu  
Scientific coordinator: MAJ Vlad-Cosmin VASILE

**Abstract:** *Through this paper, I would like to carry out a study on the security systems of the various car manufacturers. In this case we refer to the central locking systems but also to some sensors available on certain newer vehicle models. By using software defined radio devices, we will try to access the radio signal components. Then, by processing the recorded signals, we will try to discover the security breaches that can endanger the safety of the car. Depending on the problems that we will find in the security systems of the car, we will try to offer some ideas to counteract it, which we will demonstrate practically. Regarding this study, it was chosen because of the problems that have arisen in the last years when some car owners complained that their car was stolen. This started in America, after which it expanded very quickly in Europe but not only.*

**Keywords:** security, GNU Radio, URH, automobile.

## 1. Introduction

Nowadays, one of the most widespread systems regarding the immobilization of the car is the centralized locking system of the car. Using such a system, it is practically certified at the level of the control unit of the vehicle that the person who opened the car is the rightful owner or not, of the car. With the technological progress in all areas and which has a special interest and importance for daily life, the control devices have experienced an important development in all areas. Starting from the intelligent interfaces, dimensions and electronic components used in its construction, until its integration into more complex systems. And here we refer to the integration of sensors, different alarm systems but also to the locks with the fingerprint or remote opening. Therefore, the task of car manufacturers is to find the best solution to permanently protect the car they produced against theft. The first achievements started from the incorporation of an alarm system on the car body. The incorporation of this alarm system involves the integration of sensors to detect unauthorized or forced attempts to open the vehicle. The first method of implementation was the introduction of the mechanically actuated switch on all entry points into the vehicle. A second method is the implementation of sensors to detect battery voltage. This method combats attempts to interrupt the start-up circuit of the vehicle but also blocks the central ECU of the engine.

Together with these systems, the alarms can be switched separately by an IR transmitter or by mechanical key actuation. However, thieves always find ways to break these security systems, but manufacturers always strive to be one step ahead of them. Considering the fact that today, various low cost devices have been developed, the thieves have become ingenious and have started designing their own devices using some medium level knowledge in programming and digital circuits. We will see in this paper that, using a raspberry system together with a software defined radio device, we can cheat a large part of the vehicle security systems. Here we will make a reference to the systems installed in the factory but also to the systems installed by the owner, the after market ones.

**2. Problem formulation**

As we know, the classic security systems are composed in principle, of two main components: a sound warning system respectively a siren, and a control unit. Usually, the control unit is in the passenger compartment and the siren under its hood. The control unit is the one that controls the opening of the doors or the execution of a certain command such as folding the mirrors or opening the trunk. The control unit under the passenger compartment, processes the data from certain intrusion sensors, volumetric sensors that detect movements of a certain intensity. All sensors placed on the body of the car have a certain sensitivity that can be adjusted. The sensors operate on a very simple principle, when they detect vibrations that exceed a certain threshold, they transmit some electrical impulses directly to the central unit. In turn, the central unit processes the information and decides if it is time to start the siren. Second, the central unit can be controlled remotely via a remote control. This remote control can operate using radio waves, magnetic, infrared or even human fingerprints. In this case, we will refer only to those who work by radio waves because they are the most common and are found in most vehicles. But they are also the easiest to hack due to the fact that the radio signal can be picked up by a suitable device, properly configured. [1]



*Fig. 1.1 Car remote with several function*

At the same time, compared to the old systems, nowadays we can control the vehicle very easily using an internet connection or via wifi connection for relatively small distances. In case a thief tries to steal the vehicle, we can be informed in real time by a text message or by a sound signal of this fact. [2] As mentioned above, the vast majority of vehicles use a remote control that allows the owner to have access to the vehicle and allow its use. This is accomplished in the vast majority of cases by radio waves.

In this paper we will make a study that will demonstrate through a very simple scenario, how we can access a vehicle without using its key. This will be done by using a Raspberry Pi 3 platform through which we will connect a Software Defined Radio (SDR) called HackRf



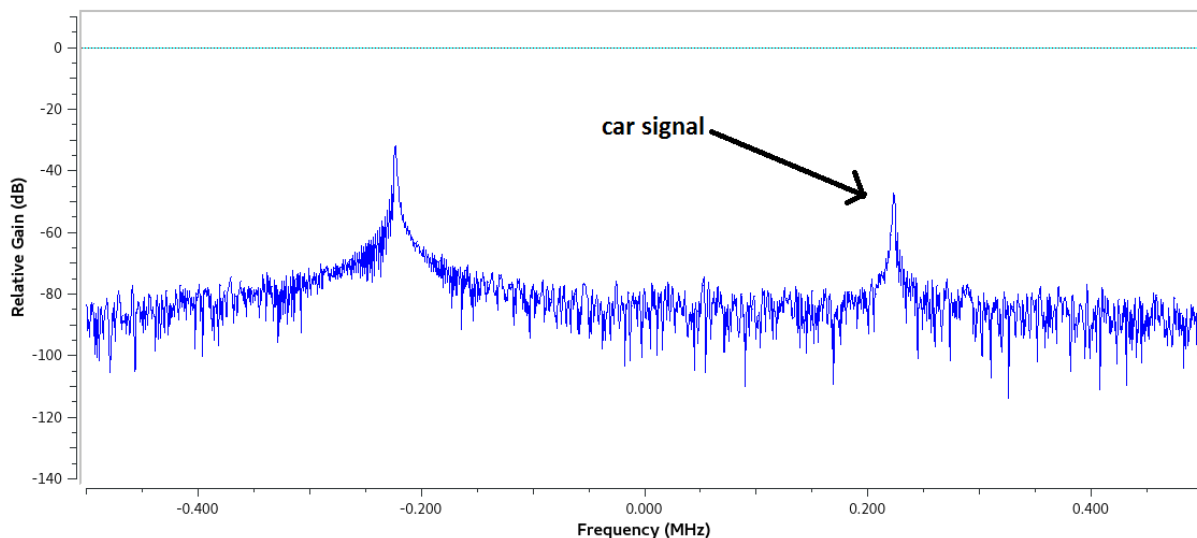

Fig. 1.3 Vehicle Remote signal at 433.27MHz

Once the signal is recorded, it can be found in a location saved by us as a .dat file type. This type of file contains a faithful replica of the signal coming from the remote control of the car. At the same time, through other software, we can see in more detail what the .dat file of the signal from the remote control of the car contains. For example, URH (Universal Radio Hacker) software is a free software that allows editing, transmitting and recording of radio signals. In the figure below, we can see what the signal recorded for a vehicle contains.

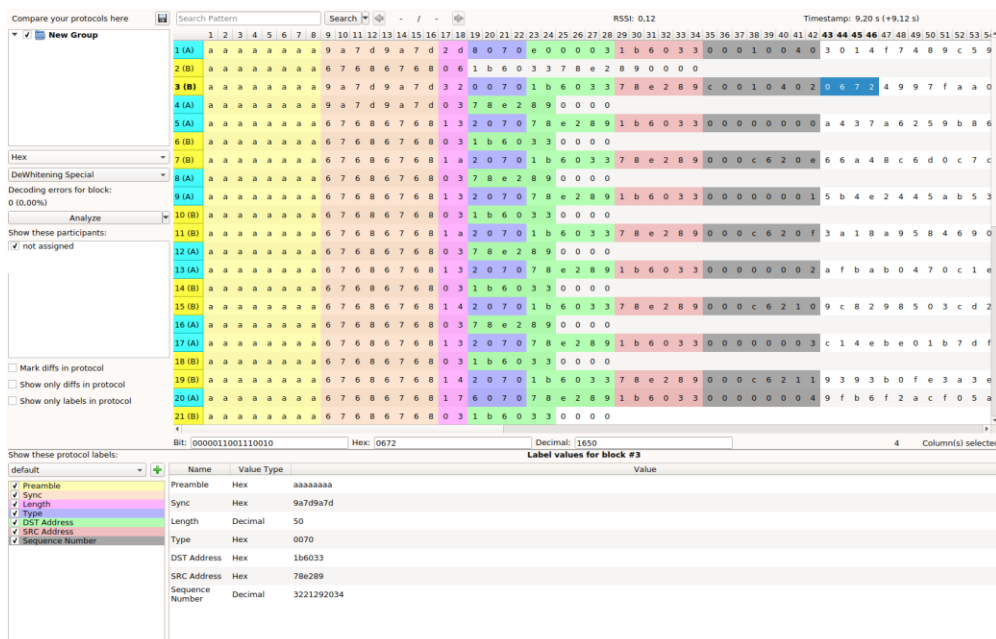

Fig. 1.4 Decoded signal from my car

The facilitation of such software is the fact that we can edit the content of the signal coming from the remote control of the car. This can have many implications because by changing certain parameters in the construction of the remote control signal, we can give other commands recognized by the central unit of the car, such as opening the doors or deactivating the sound alarm.

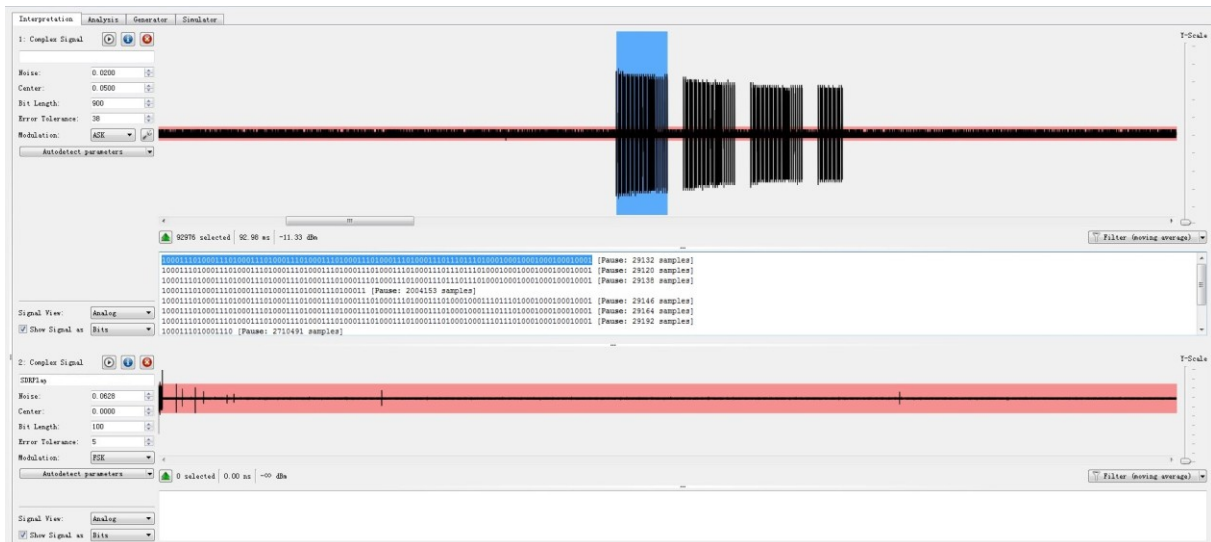

Fig. 1.5 The process of transmitting a sequence of signals from the remote control of the vehicle

For the realization of the practical part of this work, I used for own car testing. The brand name of the car will not be provided in this work. As you can see in figure 1.5 there is a sequence of 4 radio signal pulses. These impulses come from the remote control of the vehicle, the first impulse represents the opening of the doors, the second impulse represents the centralized closing of the doors, the third impulse represents the opening of the trunk and the last impulse represents the folding of the rear-view mirrors on the body of the car. By using the URH program, we will start transmitting the signal from figure 1.5 and the thing we expect is for the central unit to receive the signal transmitted by us and to order the suspension of commands related to each pulse in the signal. This has happened since the first test. However, there were several vehicle models that did not respond in any way to the same process that we applied to our own car.

Given the tests performed and analyzing the older safety systems but still existing on other models of vehicles, we can offer some solutions for improving the safety system of cars. Considering the content of the signal recorded from the remote control of the own vehicle, it was found that it is identical every time, which indicates that the key exchange between the remote control and the central unit of the car is the same each time the remote control of the car is used. A measure to combat this can be the definition of a set of keys through which, the remote control of the car and the central unit to exchange keys at a certain time and which will differ. This would mean that the key registered at time  $t$  differs from the key at time  $t + 1$ .

Another method by which the security system of the car can be improved is the encryption of the signal that is transmitted between the remote control and the central unit. This would not prevent the recording of the signal by a system built by us, but would certainly prevent the change of the signal content from the remote control. [4]

## REFERENCES

- [1] Naina Kaushik, *Anti-Theft Vehicle Security System*, (Mumbai: India, 2014), 3.
- [2] Bang Liu, Nianbo Liu and Guihai Chen, *A Low-Cost Vehicle Anti-Theft System Using Obsolete Smartphone*, (China: Shanghai, 2017).
- [3] Arthur O. Little, *Vehicle Anti-Theft Security System Design. Volume II Technical Report*, (USA: Washington DC, 2018).
- [4] Samir Rana1, Ritu Mewari, Lata Nautiyal, *Anti-theft Security System for Vehicles*, (India: Phagwara, 2018).

## **BIBLIOGRAPHY**

Dr. Pramod Sharma, Akash Shrivastav. *Smart Security System for Vehicles*. India: Bichpuri, 2019.

H I Shahadi, H T Haider, D H Muhsen. *Vehicle monitoring based on GSM technology for safety and security*. Iraq: Bagdad, 2018.

Asmita S. Udagave, S. S. Sankpal *Anti-Theft Locking For Stolen Vehicles and Canny Password Protected Access to Personalized Vehicles*. India, 2019.

M.Mathankumar, Suryaprakash Shanmugasundaram. *Development of Smart Car Security using Multi Sensors*. India: Pollachi, 2017.

# INFORMATION SYSTEMS FOR KNOWLEDGE MANAGEMENT

Ovidiu SABOU,  
Fabian URDĂ

“Nicolae Bălcescu” Land Forces Academy, Sibiu  
ovi\_96\_sabou@yahoo.com,  
urda\_fabian@yahoo.com

Scientific coordinator: Asoc.Prof. Romana Oancea, PhD

**Abstract:** *The issue of knowledge management systems has probably always been the most discussed and debated topic within knowledge management (KM). The evolution of technology is one of staggering promise and opportunity, as well with the information systems that helps knowledge management to be what it is today. Nowadays, few people would disagree with the notion that knowledge management systems are an absolutely critical part of a KM initiative. The purpose of the paper is to present what is knowledge management, why is knowledge management useful, the use of the information systems in the knowledge management and its effect on organizations.*

**Keywords:** knowledge management, information systems, technology

Knowledge-based organizations belong to the contemporary reality and mark the convergence between two defining phenomena for human nature. One of them is knowledge and the other one is organization, focusing on collective competence, intelligent action and sustainable performance. In the functioning of such organizations, the processes of innovation, continuous learning and the interaction or transfer of assimilated knowledge are decisive.

Nowadays, we are entering a new era in which the traditional means of obtaining competitive advantage, such as capital, land, raw materials and technology, are no longer the only success factors for a company or an organization. In the knowledge-based society, the success of companies depends decisively on their ability to capitalize on the most valuable resource, organizational knowledge.

Success factors are changing rapidly, continually changing the business environment and demanding flexibility and adaptability from organizations for integrating and implementing new knowledge. In the past, success factors represented productivity, efficiency and quality management but now they have been replaced by creativity, innovation and knowledge. Therefore, the optimal use of knowledge represents a new challenge for all organizations, regardless of size and field of activity.

## **Knowledge management**

Knowledge is composed from information but the information is just a small part of what knowledge is. The knowledge management are composed from the experience gained by



studying, from making connections, by reading and understanding different lessons through experience. In any organization the knowledge is viewed as the activity of “know how” or “applied action”. Nowadays organizations have a vast amount of knowledge and the only problem is how to use it. Now, we are trying to use our knowledge to get better in order to achieve the organization goals and make our life more pleasant by using more information systems in the knowledge management area.

Knowledge management is a branch of the field of managerial knowledge that deals with the implementation of knowledge actions, such as: organizing, blocking, filtering, collecting, storing, sharing, disseminating and using knowledge objects, identified as information, data, experiences, evaluations, analyzes and initiatives. Knowledge management involves capturing knowledge where it is created, sharing it with people and applying it in a productive process.

Knowledge is divided into explicit knowledge in the form of databases, documents, graphs, any file or document format that can take a physical form and that can be classified and shared within the organization, on the one hand, and tacit knowledge that take the form internal knowledge of the individual, which cannot be physically measured and which is formed over time through accumulated experience.

One of the hardest goals of any organization is to implement them tacit knowledge that brings know-how to the organization. This knowledge can be harnessed and measured when individuals make a decision, thus being able to observe the consequences. It represents the ability of people to act in a certain way depending on the environment scenario and taking into account the possible consequences of the decisions. It is worth noting the increasing importance of the human being in the organization although we are in the information age, because the success of a business requires the intelligence, knowledge and experience of the human being to translate the information available to him in the knowledge and decisions oriented towards success. Of course it is not enough for a company to have the knowledge to be successful, it is necessary that their use be oriented to meet the needs of the customers. other organizations into knowledge and to have them transforms into solutions to their needs. Knowledge management involves the dissemination of knowledge and the use of capital in the most efficient way possible, this being done when the motivation, collaboration and distribution of knowledge become almost instinctive and are part of the daily activities of the service.

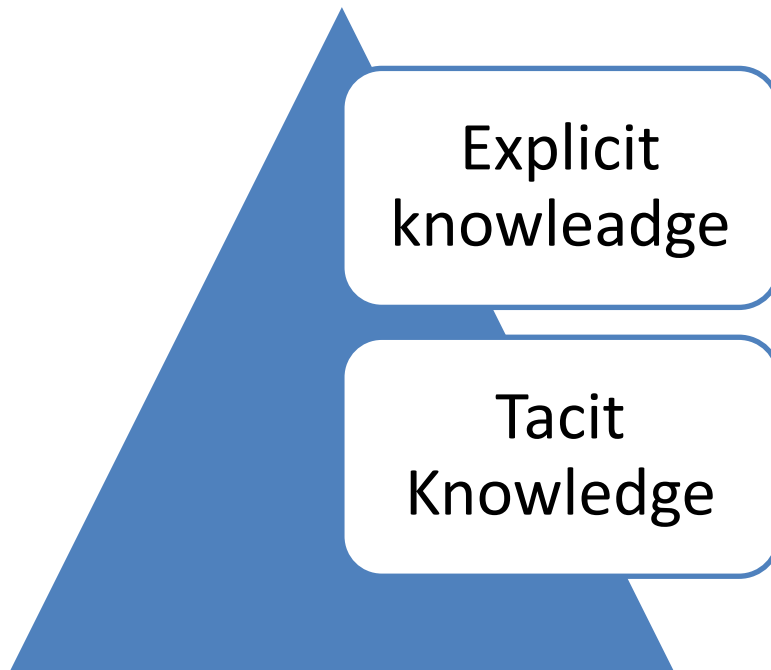

(Figure 1 Tacit and explicit knowledge)

The explicit knowledge is composed of:

- Data, information;
- Documents;
- Records;
- Files.

The tacit knowledge is composed of:

- Experience;
- Thinking;
- Competence;
- Commitment;
- Deed.

The knowledge management is useful because:

- KM helps the organization in learning from past mistakes;
- KM exploits existing knowledge assets;
- KM promotes a long-term focus on developing the right competencies and skills;
- KM helps you in developing something new;
- KM helps you protect your own knowledge.

### **Information systems and the use of them in KM**

In the new era of information technology, large companies and organizations are increasingly focusing on other than traditional means such as earth, raw material or technology to gain advantage over competitors, which are moving into the background in terms of factors successful. In the knowledge-based society, the success of organizations depends to a large extent on how they use human resources and, in particular, the knowledge of the organization. If in the past the measurement of the potential success of an organization had as factors productivity, efficiency and quality management, over time they were replaced by creativity, innovation and knowledge, all of them asking the organization to adapt continuously for the implementation of new knowledge. In conclusion, the greatest challenge

for all companies is the optimal use of the knowledge of the organization which will lead to its success.

The information system is based, according to the name, especially on information. It includes all the internal and external information used within the organization, as well as the data that were the basis for obtaining them, the procedures and techniques for obtaining information (starting from the primary data) and disseminating information, as well as the personnel involved in collecting, transmitting and transmitting information, data storage and processing. The information system does not only refer to the way in which the tools provided are used, but also to the way in which people interact with technology in an organization.

The functions of an information system are:

- To collect raw information from the decision-making systems and from the external environment;
- To save this information and collect similar information in the same database;
- To provide access to the database in order to use the stored information and help the user;

The information systems are tools used to support processes, operations, intelligence and many more. The systems move data and merge information forming the core of the informational management. They produce data-driven reports the help business make the right decisions at the right time.

There are many informational systems, such as:

- Executive Information System
- Marketing Information System
- Business Intelligence System
- Sales Force Automation System
- Customer Relationship Management System
- Transaction Processing System

### **Conclusions**

To sum up, knowledge management (KM) represents a strong tie to organizational goals and strategy, useful for some purpose and which creates value for the organization.

Both information and knowledge need to be managed but the question of how and for what purpose makes the difference. We manage information to gain knowledge and we also need knowledge to understand information at hand, but we manage knowledge to learn, to strategize and to develop intellectual capital at a higher level. As has been said, knowledge is essentially people-centric, that is what makes complex and dynamic.

To manage knowledge, you need rule-based computational linguistic routines to automatically locate and retrieve data and connections between big data sets, in other words, knowledge management needs a knowledge management system.

The information systems are used for capturing and storage of important data and relevant knowledge. By using them we can manage the knowledge resources created as an output to the gathered information in order to obtain business benefits.

### **BIBLIOGRAPHY**

G. Kebede, "Knowledge Management: An Information Science Perspective", *International Journal of Information Management* 30, (2010)

S.R. Ghani, "Knowledge Management: Tools and Techniques", *Journal of Library & Information Technology* 29, 6 (2009)

Y. Malhotra, "From Information Management to Knowledge Management: Beyond the 'Hi-Tech Hidebound' Systems", (2000)

# ACTIVE ELECTRONIC SAFE-FIRE SYSTEM

Adrian-Cătălin ȘTEFĂNESCU

“Nicolae Bălcescu” Land Forces Academy, Sibiu

Kabalan556@yahoo.com

Scientific coordinator: Assoc.Prof.Eng. Silviu Mihai PETRIȘOR, PhD

**Abstract:** *The aim of this device or set of devices is to ensure or at least decrease that the number of friendly fire cases drop by factoring out human error completely or aiding in detection of these kinds of situations. The system aims to be as simple as possible, practical and field survivable. The goal is to make it so the devices needed are either already existent, such as radio communications, or easily obtainable, such as compass sensors and electronic safety systems. Using simple mathematics and technologies already available on the market, the system will have little implementation and development costs. We intend to propose and explore one approach to this using theoretical data and calculations in the hopes that it may provide a starting point for further research. We will describe multiple possible solutions to the problem with advantages, disadvantages, function and complexity.*

**Keywords:** Communications, Infantry, Gun safety, combat.

## **Designation and base functionality:**

The goal of the device is to detect the cases where a shot may intersect or wound a friendly soldier by means of sensors and computational power using mathematics in a 2D or 3D virtual environment, depending on the complexity. A basic system will calculate a perfectly straight trajectory but with simple ballistic compensations the calculations can also factor in bullet drop or even external factors like wind. The system may also need to be calibrated in regards to the weapons used. Once such cases are detected the system should then engage the safety on the weapon that is pointed at friendly targets and such, avert the situation. The means of these functions will be detailed further only in theory in the following pages.

### Detection:

The first aspect of this device is knowing the direction each firearm is pointing at any time. This can be done in a number of ways, some simple some complex.

The first and simplest way is to use the permanent magnetic field of the earth, using a compass. An electronic one to be exact so that it will relay the direction the gun is pointing at, relative to the magnetic north, to the computer responsible for the calculations in degrees offset to the north direction. Take the first picture (figure 1) as an example. We have 3 soldiers covering 3 directions, neither pointing directly north. Starting from top to bottom the guns have the following directions: -10 degrees, +32 degrees and -46 degrees respectively. This data is then sent to each soldier's radio equipment for processing. The drawback of this method is not knowing direction on a 3D plane because we only have 2 axis of movement to work with. Another disadvantage is strong local magnetic fields that may disrupt the sensors giving false data.

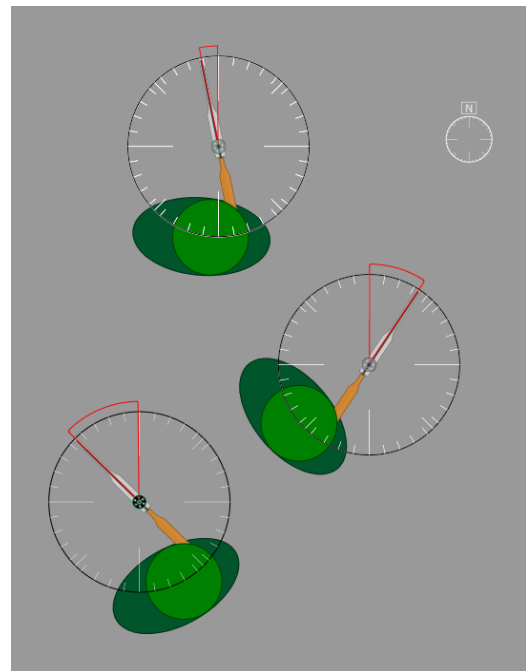

Figure 1

The second, more complex way to know the direction of each gun is to have gyroscopic sensors on each gun that will give 3D coordinates in relation to the last known position and orientation of the gun. This will rely on more expensive sensors and a larger number of them on each gun but will give better data in regards to the orientation of the gun while not being vulnerable to magnetic interference. This will also require more processing power to remember and compare the last positions to the new position so the computer can understand where, in space, the gun is pointing.

A third option to this system is combining the 2 previous methods. It will use 1 compass to give the X Y coordinates and a gyroscopic sensor to give its tilt (the Z axis) It still uses more sensors than the simple compass method but compared to the purely gyroscopic method this one has a back-up. If the gyroscope fails the system can divert calculations in a 2D plane and still function with limited capacity.

In either situation the computer will be able to mathematically create a straight line in a 2 axis/ 3 axis system of coordinates that is used in the next step of this system.

The second aspect of detection is knowing where each soldier is, at any time.

The first option is to use direct GPS coordinates that give a point in space that we can input in the calculations directly. This method relies that we have or can obtain GPS coordinates at all times or fast enough that the calculations are correct and up to date. This method implies having GPS capabilities on each soldier and signal to at least 3 satellites at any times. The advantage of this system is that the data gathered can be directly inputted into the system for the desired results

Another option is to have each radio triangulate its relative position to other soldiers in its vicinity. It can do this by taking signal strength from each radio they can connect with and the direction, based on the antennae each device has and its gain in each direction. With this information the device will not know its position on the globe but its relative position to other soldiers or a fixed point such as the home base. This system is more complex since it relies that the radio can connect to at least 3 other radios and/or home base. But this system

relies on local resources and is more robust. The more soldiers in a network, the better and more exact the calculations and such, the positions of each soldier will be.

**Calculating the interceptions:**

Once each gun has directional data in the form of an equation in a 2D/3D virtual plane/space, and each soldier a known position, the computer can then start calculation if any gun intercepts any other soldier.

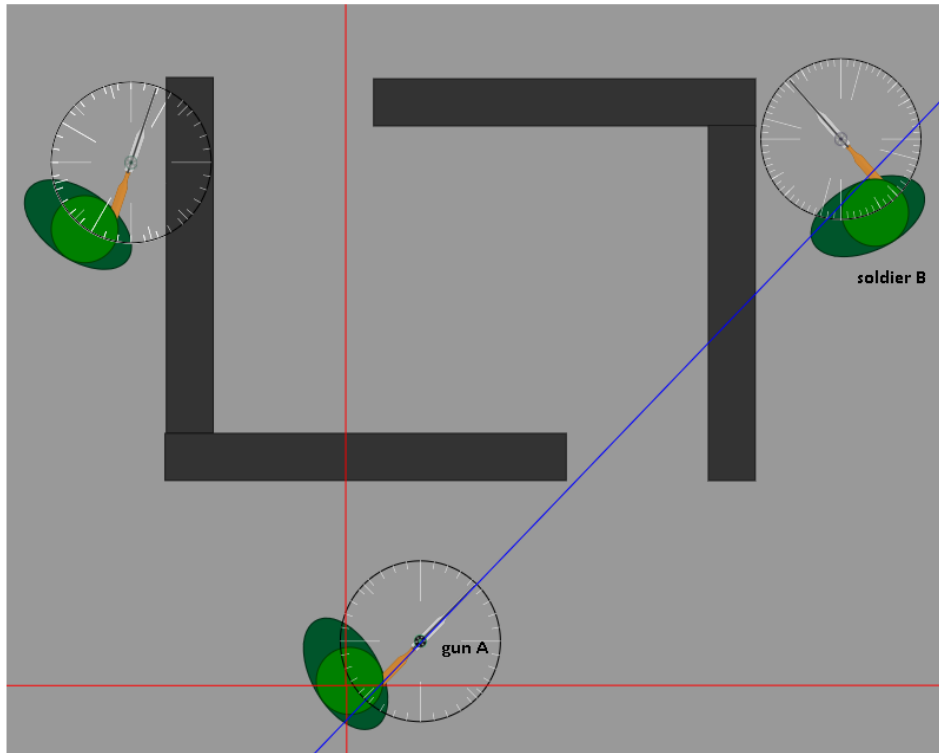

**Figure 2**

Let us take the simplest case. In this scenario (figure 2) we have 3 soldiers capturing a house with 2 doors. One of them, while covering a door, unknowingly aims his rifle through the wall to a fellow soldier. In this situation the system already knows that firing the gun now has a high probability of hitting a friendly soldier. The setup is made simple for this explanation so the gun with +45 degrees has a simple line equation. It is offset from the center of the plane but the calculations work regardless of the point of origin. Number crunching would go as follows:

Gun A line: (1)  $X-1=Y$

Soldier B position in plane: (2)  $X=11 Y=10$

Because of the nature of this experiment the soldier will not be a single point so the system will have to check an area of 2x2 (3) because the soldier is 2 wide and 1 long and can have any rotation possible. So the point (2) is the approximate middle of soldier. So any point on the line of gun A(1) that has an X greater than 10 and less than 12, with an Y greater than 9 and less than 11 is a collision with soldier B(2).

Using (1) we calculate that we have a point at  $X= 11$

Intersection: (4)  $11-1=10$

Giving:  $X=11, Y=10$  that match condition (3)

From (1) and (2) and factoring in condition (3) we conclude that equation (4) is representative of the situation. As in, the gun will hit the soldier if it is fired at that point.

The same situation in a 3D plane would go similarly. The only difference is that we now an extra Z axis denoting elevation. Say soldier B is 10 units above the ground and gun A is still interception him. Seeing as soldier B is above gun A the same distance as it far in a 2D plane, that means the gun is again, pointed a 45 degrees up as well as to the side. The new equation would look like this:

Gun A line: (5)  $X-1=Y=Z$

Soldier B position in space: (6)  $X=11 Y= 10 Z= 10$

Again we will take into consideration the volume of soldier B being equal to a  $8 \times 8 \times 8$  (7) area in space. The soldier is 2 wide 1 long but 8 tall and can be standing  $1 \times 2 \times 8$  with any rotation, crouching  $2 \times 2 \times 6$  with any rotation or in a prone position  $8 \times 2 \times 1$  with any rotation. As such any point on the line of gun A (5) that has an X greater than 7 and less than 15, with an Y greater than 6 and less than 14 and Z greater than 6 and less than 14 is a collision with soldier B (6).

Using (5) we calculate that we have a point at  $X= 10$

Intersection: (8)  $10-1=9=9$

Giving:  $X=10, Y=9, Z=9$  that match condition (7)

From (5) and (6) and factoring in condition (7) we conclude that equation (8) is representative of the situation. As in, the gun will hit the soldier if it is fired at that point.

All these calculation are extremely simplistic as a proof of concept but a computer will do even the most complex and detailed of operations fast enough for the system to be effective, given reliable data from the sensors.

### **Action**

The system having found a situation that puts the live of a friendly soldier in danger will then have to act in a way as to stop this from happening. It can do this in 2 main ways. Direct intervention or alerting of the situation.

In direct intervention the system will have to be able to engage the safe of the weapon in any moment it detects an interception. This can be possible by having an electric engine directly on the safety, internally or externally, on the gun. This is already done on fingerprint safety weapons but is not impossible to implement on any kind of firearm.

This method ensures that the gun cannot be fired if an interception is detected, completely ruling out human error but it can also mean that situations may appear where the gun must be fired to incapacitate an enemy but the system will not permit it because there is a soldier behind the enemy, even if said soldier is in no real danger (he is in cover or too far away) This method also creates the vulnerability that if, somehow, the enemy uses a device to trick the system into always detecting an interception, the guns will always be on safety, rendering them useless.

The alerting possibility involves a clear signal to the user of the gun and/or to the soldier in danger, alerting them of the situation, urging them to change position until the interception clears.

This method relies on the alertness of each soldier and even if it does not completely prevent unwanted friendly fire, it reduces the probability since a soldier can know if he is in danger by the system alerting him. This method does not remove the human element from the equation so results may not be 100% efficient. But an upside to this method is that even if the system malfunctions or is in some way hacked by the enemy, the guns can still be fired as the system does not have direct control over them.

### **Pros and cons**

The simplest system can provide at least useful information to soldiers regarding their position on the battlefield. Using the alert method soldiers can even “scan” for each other through walls to have a better understanding of the situation. The more complex solution offers redundancies and more safety at the expense of agency and cost.

Pros as a whole:

- Low financial impact.
- Easy to use and understand.
- Easy to deactivate in case of malfunction, not affecting basic soldier performance.
- Flexibility.
- Better battlefield awareness.
- Can be 100% independent (compass method with radio triangulation method).

Cons as a whole:

- Vulnerable to magnetic fields (in the case of compass method).
- Reliance on infrastructure (satellites in case of GPS method) that may not work at all times.
- Slight increase in equipment weight
- Vulnerable to enemy sabotage with unwanted results (in the case of direct intervention method)

### **BIBLIOGRAPHY**

Electronic compass sensors : <https://www.elprocus.com/compass-sensor-working-and-applications/>

Gyro sensors: [https://www.epsondevice.com/en/information/technical\\_info/gyro/](https://www.epsondevice.com/en/information/technical_info/gyro/)

Electronic firearm safety system: <https://slate.com/technology/2016/01/smart-gun-safety-technology-explained.html>

GPS tracking: <https://www.lifewire.com/how-car-gps-trackers-work-4147185>

Radio triangulation: <https://hackaday.io/project/25995-bloodhound-autonomous-radiolocation-drone/log/63866-radio-direction-finding-techniques>

Richard N. Aufmann, Joanne Lockwood. Intermediate Algebra: An Applied Approach, Cengage Learning, 2013



# IDENTIFICATION, PREVENTION AND CONTRACTION OF THREATS AND VULNERABILITY OF COMMUNICATION AND INFORMATION SYSTEMS

Dumitru Alexandru SUCALĂ

“Nicolae Bălcescu” Land Forces Academy, Sibiu

[alex.sucala93@gmail.com](mailto:alex.sucala93@gmail.com)

Scientific coordinator: COL Assoc.Prof.Eng. Ioan VIRCA, PhD

**Abstract:** *Technological developments in recent decades have generated a strong dependence on society by electronic and virtual means of communication, as well as widespread awareness, from ordinary people to political leaders and multinational societies, to terrorists. The security of information and communication systems in today's society has become an extremely important issue, which must be taken into account by both equipment manufacturers, application developers and system integrators, network administrators and end users. The dynamics of information technology always brings new challenges, before which institutions have to introduce new protection systems.*

**Keywords:** vulnerability, communication and information systems, IT.

## **Introduction**

Many vulnerabilities in communications networks are easy to exploit, and people and organizations everywhere can connect to these networks, beyond national borders.

With the use of information technology with determination, in the case in which its economy is affected, it is safe for the population, so that the profile of the cyber attack may sometimes have the features of terrorist acts, bad habits and bad habits. sensitive information.

Such acts take place equally in classified and sensitive networks (their governmental networks belonging to state-owned or private organizations, networks with international scope, NATO, EU and other public bodies). We must mention the fact that the Internet has become a global structure, connecting millions of networks, hundreds of millions of personal computers, as well as many other devices such as mobile phones, smart phones, tablets, PDAs, etc.

Also, this global network plays a decisive role in the efficient functioning of various fields: business, banks, trade, public administration, the river and in defense and national security.

## **The main dysfunctions and vulnerabilities in the IT&C domain**

The main dysfunctions and vulnerabilities in the IT&C domain, as evidenced by the research carried out by the specialists of the field are:

1. Unprotected storage of confidential data (access passwords, accounts, etc.). Confidential data can end up being stored without any protection or by using weak protection methods.

2. The use of outdated software versions, whose problems have been identified and solved in later versions, decreases the security level of the system.

3. Easy access to files with sensitive data. In some situations there are files with important data that can be easily accessed on the Internet, which is practically public. Whether this is due to negligence or a security breach, these files may contain sensitive or useful information that may become the subject of computer attacks.

4. Disclosure of some technical details. There are certain cases where an application discloses sensitive technical details when one of its components does not work, confidential information being made public through the displayed error messages.

5. Lack of data validation on the server side. It is the situation where it is discovered that the validation of the data entered by a user is done in the interface displayed by the browser, not at the server level. This exposes application to many types of tasks.

6. Confidential data is not transmitted using a secure protocol. Sometimes only a few pages are secured (login, register, checkout, etc.) and not the entire site, which makes it possible to steal session / identity just as easily as on a site that is not protected by a security certificate.

7. The application configuration files are stored in public directories. This vulnerability increases the risk that configuration data, including passwords or other sensitive data, may be accessed by unauthorized personnel. Once the main vulnerabilities of the information systems have been identified, the next step is to implement protection methods based on the vulnerabilities discovered in order to prevent their exploitation. The assessment of these vulnerabilities consists in identifying, quantifying and prioritizing an IT system (computers, networks, communications).

We call vulnerability the weak link of the system, application, infrastructure, control mode, or network design, which can be exploited to destabilize the system or to interrupt the activity. Vulnerability is a feature of the system that exposes it to threats. A vulnerability that can not be exploited by a threat is not dangerous to the institution.

At the same time, the vulnerability can be manifested as a weakness of the IT environment which leads to the possibility of exercising unauthorized access. Information systems are vulnerable both to natural disasters (fires, floods, earthquakes, voltage drops) and threats from the environment. Software malfunctions can disrupt the proper functioning of a computer system. When the hardware or software components are incorrectly connected or the software is not properly installed and configured, the system can no longer function effectively. Networks are vulnerable because the information stored and transmitted can be intercepted, analyzed and decrypted. Any communication in the computer systems is done by providing some hardware encryption equipment, and any large system must provide from the beginning alternative communication solutions, which take over the traffic in case of incidents.

Depending on the level at which they occur, vulnerabilities can be classified as follows:

- implementation vulnerabilities (due to deficiencies in the implementation of security solutions specific to the computer system);

- configuration vulnerabilities (there are errors that occur in the configuration of the systems by using access codes or writing password files). The configuration adopted for different computer equipment and systems must be secure and detect any possible vulnerability, for example weak access passwords;

- vulnerabilities of the human component (due to poor training in the field of computer security of users leading to incorrect administration of the system);

- managerial vulnerabilities (due to lack of security concern, lack of internal audit activities).

In the IT domain the vulnerabilities can be:

- physical: the offices or rooms in which the computers are located are vulnerable by the possibility of physical intrusions, the purpose of these intrusions being to steal or alter data and equipment;

- natural: this category includes fires, floods, earthquakes, interruptions of electricity supply, high humidity;

- hardware and software: configurations of existing systems that can cause security breaches to occur;

- emission: all electrical and electronic equipment emits electromagnetic radiation that can be intercepted;

- communication: adding a new computer to the network increases the risk that someone else may be able to penetrate the system. Messages can be intercepted, diverted and forged. The more appropriate the security measures, the lower the risk of data interception or transmission distortion;

- human: they are represented by system administrators and users.

### **The main methods of protecting the information and communication systems**

The main methods of protecting the information and communication systems are to secure the information stored on these systems. Securization can be implemented by various methods starting from locking rooms with computers, protecting access to the computer network with passwords, encrypting telecommunications lines in computer networks until using special technologies to prevent the interception of different radiations emitted by computing equipment. during normal operation.

The main risk prevention methods for information and communication systems are:

#### **1. Control the access to the system**

Each component of the information system must be subject to access control measures, the data must be protected regardless of the form or state that characterizes them, whether it is software applications, operating systems, databases or communications networks. In order to identify the unauthorized activities it is necessary both the access monitoring and the way in which the computer system is used.

#### **2. Administration of the system and implementation of security policies**

This method consists in developing, planning and performing independent procedures to ensure system security, as well as delimiting the responsibilities of the system administrator, training and controlling users to ensure that security policies are respected.

#### **3. The architecture of computer systems and computer networks**

In addition to the performance criteria, the design of an IT system is based on criteria and rules regarding the security of the respective system. In the IT&C field, we must not forget that any communication will be done by providing encryption hardware equipment, as well as establishing alternative communications solutions, which will take over traffic in the event of incidents in the main transmission system.

#### **4. Encryption**

Data that can be read and understood without special measures is called clear data. The method by which clear data is masked in such a way as to hide the essence is called encryption, resulting in encrypted data.

## **BIBLIOGRAPHY**

Hubbard D., *How to Measure Anything: Finding the Value of Intangibles in Business*, Editura Wiley, 2010.

Ruse C., *Dictionary of Current English*, Oxford, Oxford University Press, Second Edition, 1988.

Zhang Y., Lee W., Huang Y., *Intrusion Detection Techniques for Mobile Wireless Networks*, in "Proceedings of USENIX Symposium on Mobile and Location Independent Computing", Cambridge, Massachusetts, 2012.

# MEANS OF IMPROVING THE ACTIVITIES SPECIFIC TO THE MOVING AND TRANSPORTATION MISSIONS OF INFANTRY SUBUNITES

Traian-Alexandru TIMOCE

“Nicolae Bălcescu” Land Forces Academy, Sibiu

tentatzie70@yahoo.com

Scientific coordinator: Assoc.Prof. Vasile ROMAN, PhD

**Abstract:** *The topic chosen for the elaboration of my presentation entitled "MEANS OF IMPROVING THE ACTIVITIES SPECIFIC TO THE MOVING AND TRANSPORTATION MISSIONS OF INFANTRY SUBUNITES" deals with a problem that all the military structures are confronted with, very important and decisive in the result of a conflict. Due to the multiple missions that Romania performs within the North Atlantic Treaty Organization, being a member since 2004, and because of the permanent risk coming from the west of the continent, the missions of movement and transport of troops are strategically vital. All the missions carried out over time have shown that success cannot be achieved without being dependent on movement and transport. The infantry subunits, starting with the group level and ending with the brigade or division ones, in order to successfully carry out their received mission, are dependent on movement and transport, which ensures their safety and high combat ability. Improvement of these troop movement and transport activities would have a beneficial impact on the success rate of the missions carried out by the infantry sub-units, because the sub-unit (military) members would arrive faster at the ordered place, have a higher safety in transport time and higher combat capacity*

**Keywords:** improving, movement and transport, infantry

## General principles regarding movement and transport in the military field

Movement and transportation is one of the most important basic functional areas of logistics and includes all the capabilities, activities, resources and functions necessary to change the place of disposal of military forces, equipment and materials.

Movement and transport in the military field, more precisely within the Romanian armed forces, are carried out by land, air and naval.<sup>1</sup>

**Land transport** is one of the most widespread movement and transport forces, with the framework of road and rail transport. Road transport is the main way of moving sub-units, materials and equipment, with the purpose of successfully carrying out missions, which take

---

<sup>1</sup>F.T./Au.-4 Manualul pentru luptă al plutonului de transport, București, 2015,p.5.

place on national or other territories. Rail transport is carried out for travel / dislocation of troops, military equipment and materials in theaters of operations. This type of transport can be done on both short and long distances.

**Air transport** has long been considered a luxury means of transport, a type of transport that not all countries allow, but at the moment it is the best transport for subunits, expensive equipment and armament, due to the fact that reaching the ordered destination is realized shortly. Air transport is the fastest means of moving the armed forces, having the ability to be deployed in theaters of operations in less than 24 hours. For transport, mixed aircraft, passenger and freight aircraft, and special aircraft for deploying military equipment and equipment are used.

**Naval transport** is known as the most reasonable means of transport, especially of goods in terms of cost, but not in terms of time. This type of transport is less common in the movement of forces, military personnel and materials, the main reason being that the travel time to the destination is much higher compared to air transport, but nevertheless, the own army is equipped with several types of ships that allow troops to move.<sup>2</sup>

#### **The principles of movement and transport**

The activities carried out within the movement and transport are similar to those carried out in the field of logistics, but they are little changed due to the specific requirements of this field of activity, and these are based on the experience gained during the conduct of the military operations and actions. The basic principles of movement and transport are: Responsibility, Cooperation, Coordination, Efficiency, Opportunity, Safety, Efficiency, Flexibility, Standardization, Compatibility, Tracking and Transparency.

**The responsibility** has a collective character in the field of movement and transport, it is applied starting from the planning phase of the joint operation and is continued in the phases of dislocation, stationing, receiving and continuing the movement of forces, as well as for their support and relocation.

**Cooperation** involves making every effort to ensure the desired support for movement and transport, and this is achieved at national, multinational level, for all levels of mobility and in all phases of military operations.

**Coordination** ensures the performance of all activities involved in supporting the movement of forces and the associated logistical support, the coordination is carried out at the same level as the cooperation.

**Effectiveness** requires that the planning and execution of the movement and transport be up to the level and requirements of the operations.

---

<sup>2</sup>L-14/1, INSTRUCȚIUNI PRIVIND OPERAȚIUNILE DE MIȘCARE ȘI TRANSPORT ALE UNITĂȚILOR ȘI MARILOR UNITĂȚI, BUCUREȘTI, 2005, pp.15-16.

**Opportunity** implies that the planning and execution of the movement and transport must be carried out under the conditions and within the established deadlines, according to the concrete requirements and properties of the work.

**Efficiency** is the use of resources and facilities with high efficiency in the field of movement and transport. Efficiency can be found in the economic report of the use of resources, in which is represented the cost and the yield given in a certain mission / time period.

**Flexibility** refers to the fact that the modification or adaptation of a planning and execution of the movement and transport does not influence the mission's execution and execution itself.

**Standardization** facilitates the accomplishment of the missions of movement and transport and is applied for the procedures used in the planning and coordination of the execution of the operations of movement and transport, as well as for the data, the information, the components and the software and hardware systems.

**Transport compatibility** requires that all equipment, technique and materials provided by the armed forces, especially those with high mobility, be established so that they can be transported with transport resources.

**The tracking and transparency** of the informational details during the planning and execution of the movements and transports, between the military and the civil structures, ensures the efficiency and the accomplishment of the missions received from the upper echelon.<sup>3</sup>

#### **The displacement of the forces**

The displacement of the forces within the Romanian Army is made only on the basis of the travel order, the transport being made by road, rail, air or naval. In the case of moving forces in march on vehicles, they will move in the column, with certain distances between vehicles, specified in the order of movement and with a speed mentioned in the same place.<sup>4</sup> For the execution of the transport, the transported forces are assigned the following:

- a) Basic and backup boarding district;
- b) Direction of transport, base and reserve;
- c) Landing area, base and reserve;<sup>5</sup>

The execution of the operations of movement and transport is facilitated by:

- a) The existence of SOPs (standard operating procedures);

---

<sup>3</sup>L-14/1, INSTRUCȚIUNI PRIVIND OPERAȚIUNILE DE MIȘCARE ȘI TRANSPORT ALE UNITĂȚILOR ȘI MARILOR UNITĂȚI, BUCUREȘTI, 2005, pp.15-16.

<sup>4</sup>F.T./Au-3, Manualul pentru luptă al companiei de transport, București, 2015, p.36.

<sup>5</sup>F.T./Au.-4 Manualul pentru luptă al plutonului de transport, București, art. 195.

- b) Existence of plans for loading the technique and materials;
- c) The existence of transport plans;
- d) Existence of reserves for the replacement of materials or equipment for boarding;
- e) Existence of the means of embarkation / disembarkation of the technique and materials;
- f) Execution of transport execution exercises<sup>6</sup>

### **March**

One of the main methods of movement and transport is represented by the march. The execution of the march consists of the movement of the subunits in the column, it is executed especially at night, rarely the day, but in case of low visibility it can be executed also the day. When executing a daytime march, it runs far behind its own device, the chance for subunits to encounter enemy forces is almost nil.

The displacement can be executed by normal march, in conditions favorable to one's own forces, with average speeds, respecting all the elements of the movement, these being the stops (big and small) and the rest of night or day, or by a forced march, this executing itself in the situations in which the sub-units have to pass the missions during the shortest time, with maximum speed of movement, increasing the attention because the encounter with the adversary's forces can occur at any time. The speed of march is an average of the speeds realized on some portions of terrain, this being expressed in km per hour. In the dry land, the speed per day is 20-30 km per hour, and at night it is 15-20 km per hour; in forested land, the walking speed is reduced by about 30-40% compared to that in the plains. During frost or when the road is slippery, the walking speed is reduced to 10-15 km per hour.

At night, if the vehicles are equipped with night vision equipment, or when the road is illuminated and equipped with indicators, the speed of travel is the same as the daytime speed. The speed of movement is directly proportional to the mobility of the military structures. The mobility of the forces, the opportune ability to move through the march, decisively influences the maneuver of forces and means, the concentration and the movement of forces within the adopted forms and means of combat, the change of the efforts from one direction to another and the timely exploitation of the effects of the blows executed on the enemy with different categories of armament.<sup>7</sup>

### **Security of displacement of forces**

Considering that at any moment the movement of forces is endangered by the presence of the enemy, its counteracting and avoiding incidents are achieved by allocating forces that ensure the safe execution of transport and all the activities of moving forces. The safety is carried out by its own sources or it is provided by specially trained forces in this regard, as a rule this activity is intended for the Military Police platoon.

**In conclusion**, movement and transport is one of the most important basic functional areas of logistics and includes all the capabilities, activities, resources and functions necessary

---

<sup>6</sup>F.T./Au.-4 Manualul pentru luptă al plutonului de transport, București, 2008, art.166.

<sup>7</sup>F.T./Au.-4 Manualul pentru luptă al plutonului de transport, București, 2008, art.176



to change the place of disposal of military forces, equipment and materials. The movement and transport of the infantry subunits is in continuous development, this being very beneficial for the movement and transport of the infantry subunits, influencing the performance of the missions, these being met with a lower level of difficulty.

#### **BIBLIOGRAPHY:**

- F.T./Au.-4 Manualul pentru luptă al plutonului de transport, București, 2015  
L-14/1, Instrucțiuni privind operațiunile de mișcare și transport ale unităților și marilor unități, BUCUREȘTI, 2005  
F.T./Au-3, Manualul pentru luptă al companiei de transport, București, 2015
-

# THE IMPORTANCE OF SPECTRAL ANALYSER IN TACTICAL FIELD OBSERVATION

Marian Mădălin VLADU  
“Nicolae Bălcescu” Land Forces Academy, Sibiu  
vladu.madalin11@gmail.com  
Scientific coordinator: Prof. Mircea VLADU, PhD

**Abstract:** *A spectrum analyzer measures the magnitude of an input signal versus frequency within the full frequency range of the instrument. The primary use is to measure the power of the spectrum of known and unknown signals. The spectrum analyzer help us to detect wireless transmitters of other forces. In this paper I aim to demonstrate the importance of spectral analysis in the discovery of the tactical field, by intercepting and tracking transmissions by the enemy. I will exemplify this by highlighting a few measurements made using a spectral analyzer in the Land Forces Academy instructional poligon. The results will be procesed with statistic means to conclude the distribution of powers of signals in our operation area.*

**Keywords:** spectral analyzer, intercepting, measurements, tactical field

Spectral analysis represents the transformation of a signal from the time domain into the frequency domain. In the military field we use this analysis to scan the frequency spectrum from the tactical field. So we can see if there are other military forces in our area of action than the ones we know. With the help of a spectral analyzer we can observe if electromagnetic wave transmissions are made in the tactical field, but we cannot locate the position of the emission source of the electromagnetic waves. The triangulation method is used to locate the emission source of the electromagnetic waves. This method represents the use of the spectral analyzer to perform measurements from three different positions to determine three axes passing through the wave emission source, so that by intersecting the axes that intercept the transmitted signal we will obtain the position of the emission source. The position is very easy to determine if the broadcast station is a fixed one, if this operation is mobile, it becomes much more complex. The Romanian army has a special vehicle with which we can obtain the approximate position of the emission source of the electromagnetic waves, without the need for measurements made from different positions.

Spectral analysis is performed with the help of a spectrum analyzer that measures the amplitude of an input signal in relation to the frequency, within the complete frequency range of the instrument. The spectrum analysis has been produced since the 19th century. Engineer Jean Baptiste Fourier developed the Fourier series for thermal conduction, so later the Discrete Fourier Transform and the Quick Fourier Transform appeared.

All spectral analyzers used today use FFT. The analysis with the help of FFT starts with the sampling. Therefore the output signal will be represented by a succession of voltage levels transmitted to an analog-digital converter. The resulting levels are more accurate as the number of bits represented by them is higher. The maximum frequency of the signal that can

be encoded is determined by the sampling rate, so that the sampling frequency must be at least double compared to the current maximum frequency of the signal to be sampled. This rule used in the field of spectral analysis is known as the Nyquist condition.

$$T = \frac{1}{2f_M} \quad (1)$$

This device also calculates the density of the flux power  $S$ , and the wavelength  $\lambda$  using the formulas:

$$S \left[ \frac{W}{m^2} \right] = E \left[ \frac{V}{m} \right] * H \left[ \frac{A}{m} \right] \quad (2)$$

$$\lambda = \frac{c}{f} \quad (3)$$

Next I will present the Aliasing phenomenon. This phenomenon occurs when the actual signal frequency is higher than the sampling frequency. Thus the frequency of the output signal will be very low, and the representation will no longer be the correct one. To avoid aliasing, the best option is to pass the signal through a low-pass filter, with the filtering frequency less than half of the sampling frequency. The newest FFT spectral analyzers use in the low-pass filter a sampling frequency of at least 2.56 times higher than the filtering frequency of the signal. The phenomenon of aliasing also occurs in other environments, such as moving images.

In the spectral analysis of digital signals, FFT analyzers use three sampling rules:

- Data collected is passed through a low-pass anti-aliasing filter;
- The Nyquist condition is met whereby the sampling frequency must be at least twice the maximum frequency of the signal to be analyzed;
- The response frequency to be analyzed is proportional to the sampling frequency.

To perform the measurements in the tactical field we used a spectral analyzer in short waves from the equipment of the Ground Forces Academy "Nicolae Bălcescu", SPECTRAN HF 6065. This analyzer is one based on heterodyne, being the fourth generation of spectral analyzers. Therefore the speed of the measurements is much higher than in the previous generation, the frequency band in which they make measurements has also been increased and the display has been improved. Therefore the SPECTRAN HF 6065 analyzer detects the frequency sources, determines the intensity and frequency of the source signal, and decreases the phase noise. The frequency spectrum in which the analyzer performs measurements is quite large, from 100 MHz to 6 GHz, it can perform measurements in different units of measurement such as dBm, W / m, A / m etc. Other features of this device include the possibility of connecting to the computer using the USB interface, analyzing and processing the data collected by the analyzer using the software in the computer, as well as charging it from other power sources such as the 12V power outlet. at the car. In addition to this spectral analyzer, we also used the HyperLOG 7060 directional antenna, with which we can make measurements in the frequency spectrum between 700 MHz and 6 GHz, with a gain of 5 dBi.

Below I will show some measurements made using the SPECTRAN HF-6065 spectral analyzer connected to the HyperLOG 7060 antenna. These measurements have the role of highlighting the discovery of emission sources, such as the mobile phone. For this we used the frequencies corresponding to 3G and 4G bands, and analyzed the signal of two telephone companies, VODAFONE and TELEKOM.

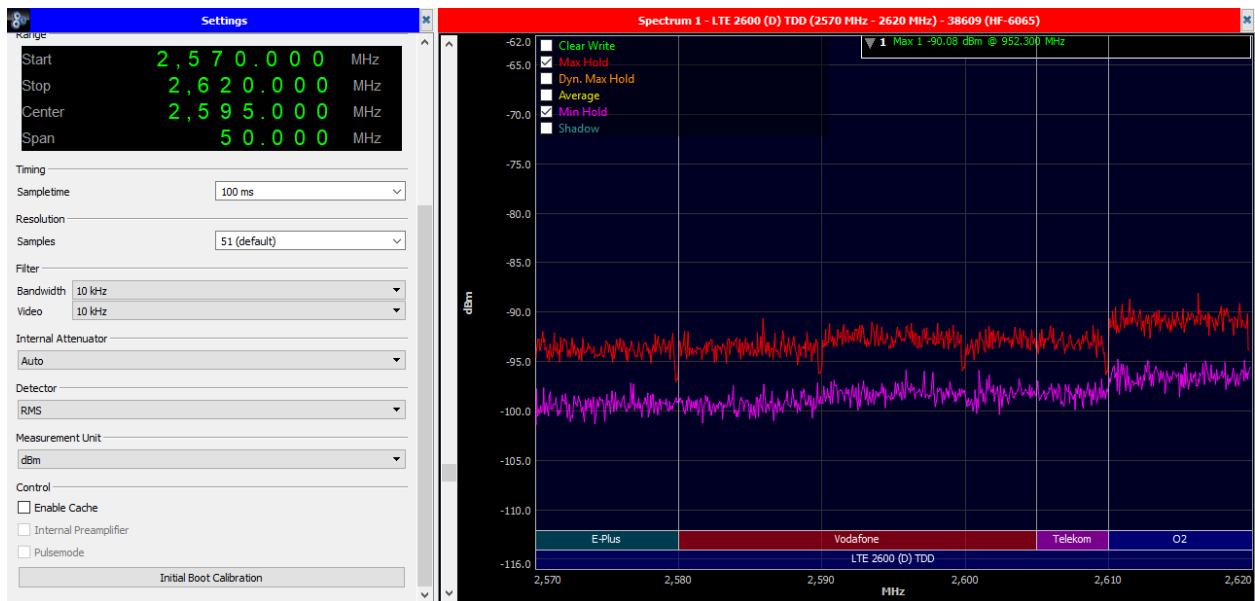

Figure 1

In figure 1 highlighted above we observe the signal analysis in the 4G frequency band, this being between 2570 MHz and 2630 MHz. The bandwidth used is 10 kHz, so the signal is much better highlighted and the measurements are more accurate, also the time between measurements was set to 100 ms to improve the results. It can be seen that the signal strength provided by VODAFONE is stronger than that of TELEKOM. Therefore, a phone that is in the VODAFONE network will be much easier to identify than one from the other network. During the signal several amplitudes of the signal are observed, those are the representations of the data transmissions in this network. This figure was made using the software that the spectral analyzer has for the connection to the computer via the USB cable. Through this software we can identify a multitude of data, also we can set the measurement parameters of the analyzer, as well as their display in different types of graphs.

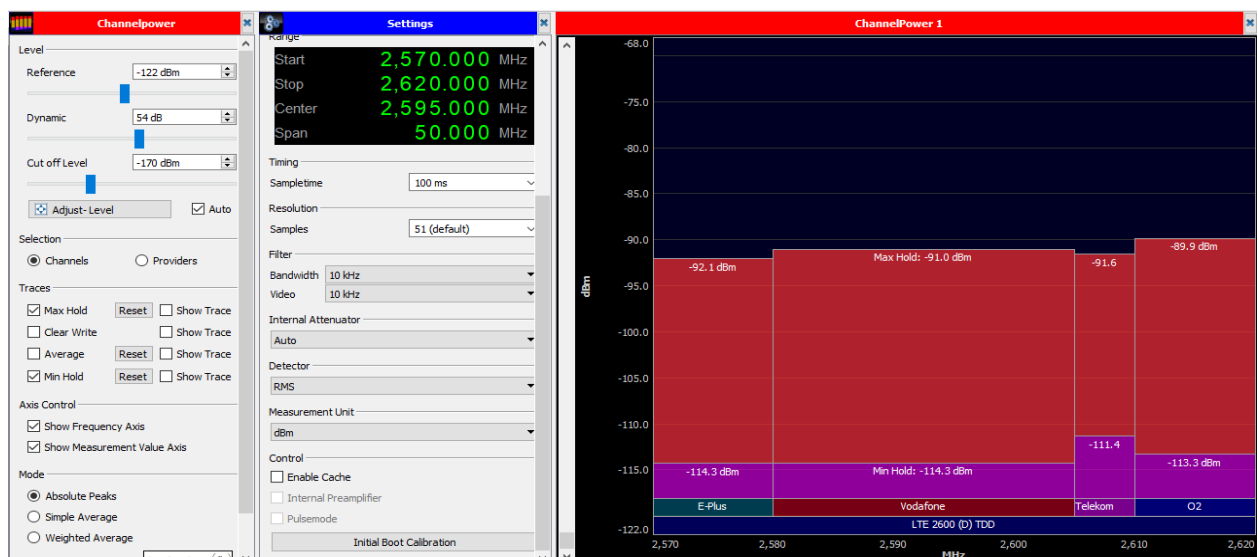

Figure 2

In figure 2 we can see the power of the channels of the two operators, so that the maximum and minimum values in the 4G band are presented. Therefore VODAFONE has a maximum transmission power of -91 dBm and the minimum transmission power is -114.1 dBm offered by TELEKOM.

These were the measurements made in the 4G band. I will also present the measurements made in the 3G band.

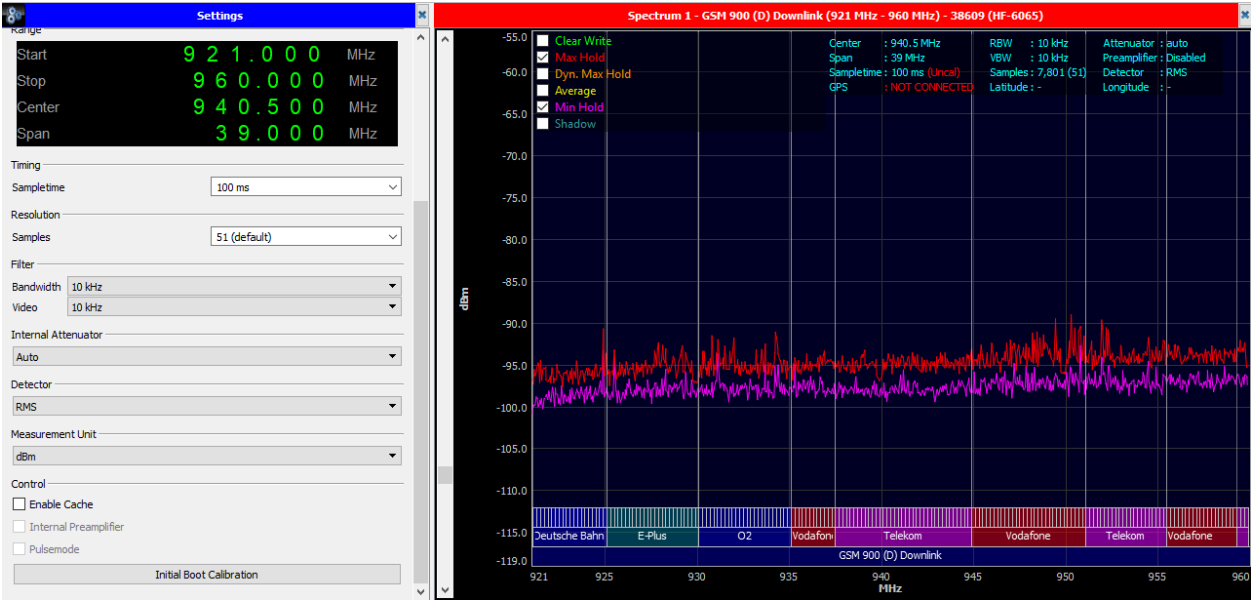

Figure 3

Figure 3 represents the signal offered by the two telephone service providers in the 3G band. This band is between 920 MHz and 960 MHz, the bandwidth used is as in 4G band is 10 kHz and the time between measurements 100ms. As in the 4G frequency band we can say that the signal provided by VODAFONE is stronger than that of TELEKOM.

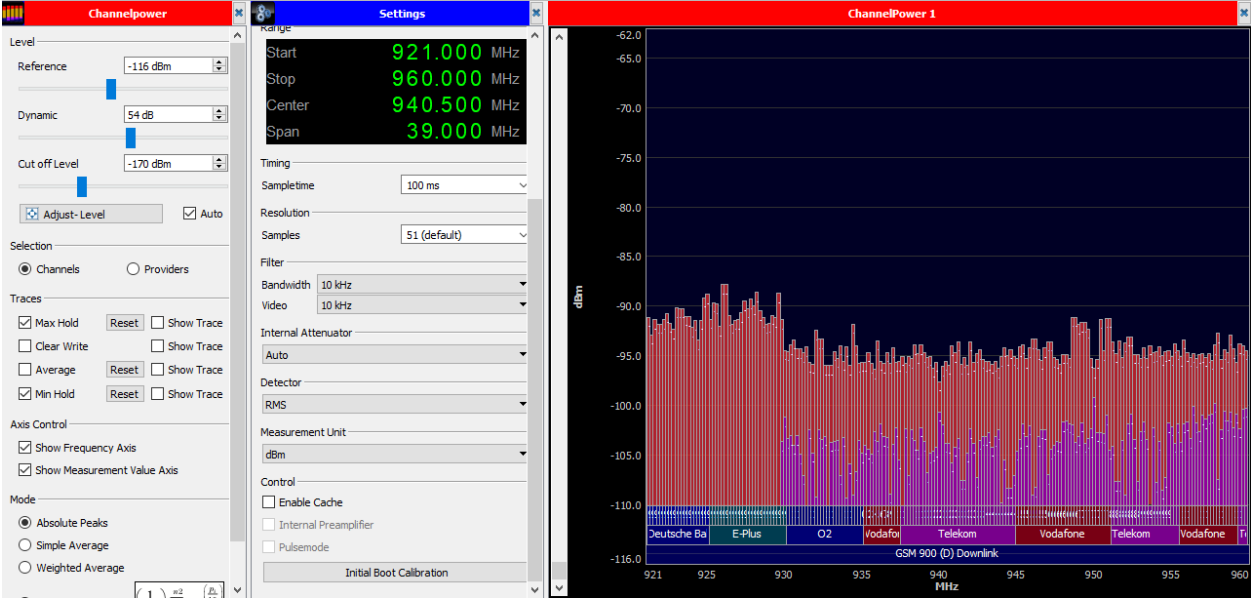

Figure 4

Figure 4 shows the power of the channels of the two providers in the 3G frequency bay, so that the maximum transmission power is -91 dBm offered by VODAFONE, and the minimum power is -110 dBm offered by the other company.

With the help of the measurements made, we showed the powers of the signals offered by two service operators, so that identifying these signals helps us to discover the different emission sources. We used the frequencies corresponding to the 3G and 4G bands to show the

shape of the signal identified by the spectral analyzer. In order to identify the exact location of the emission source, measurements from different positions are required, as well as this location being more difficult to realize if the transmitter is in the room because the effect of reflection due to the walls or other materials inside the buildings appears.

#### **BIBLIOGRAPHY**

AARONIA AG, Manual SPECTRAN V4, 2017

[http://www.mobilindustrial.ro/current\\_version/online\\_docs/COMPENDIU/analiza\\_spectrala.htm?mw=MjQw&st=MA==&sct=MA==&ms=AAAAAAA=](http://www.mobilindustrial.ro/current_version/online_docs/COMPENDIU/analiza_spectrala.htm?mw=MjQw&st=MA==&sct=MA==&ms=AAAAAAA=)

# PROGRAMMING WEB INTERFACES FOR DATABASES USING PHP AND MYSQL

Alexandru Constantin VOICA

"Nicolae Bălcescu" Land Forces Academy, Sibiu

voica\_alex@yahoo.com

Scientific coordinator: Assist.Prof. Alina BABOȘ, PhD

**Abstract:** *The emergence of web applications has led to the mass use of the web. Millions of companies use the internet as an accessible means of communication. There are over one million Internet users today. The marketing team uses the internet to communicate with visitors who access websites. Thus, tactics are used, such as persuading web visitors to subscribe to newsletters and fill in application forms when requesting product information. A large number of companies also use the web as a sales channel. In other words, web applications are increasingly being used. This is also due to the fact that they have a lot of advantages, namely the fact that web applications do not require installation, ease of use, speed of response.*

**Keywords:** programming, databases, php, mysql, css

## 1. WEB SERVICE AND WEB APPLICATION

In order to better understand the concept of web service, and what it represents, we first need to provide several definitions that clarify certain elements:

The web service phrase is:

- (generic) a service provided by an electronic device to another electronic device, which sends information between them via the World Wide Web.
- (specifically) a web service applied in a unique technology, for example W3C [1].

In a web service, Web technology, such as HTTP, initially designed to maintain the human-machine connection, is used for machine-to-machine networking, more specifically for transmitting file formats such as XML and JSON [2].

In IT, a web application is a client-server platform that the client uses together with a web browser. The usual web programs contain webmail, online retail and virtual auction [3].

Web applications are usually programmed in browser-supported language, such as JavaScript and HTML, because these languages are browser-based to render the program. Some of the existing applications are dynamic, requiring server-side processing. And some of them are completely static without server processing.

The web application needs a web server to manage user needs, an application server to perform the required tasks, and sometimes a database for storing information. Application server technology ranges from ASP.NET, ASP and ColdFusion [4], to PHP and JSP.

## 2. PROGRAMING LANGUAGE

In this part I will approach the programming languages whether it is server or client programming languages and I will detail the concept of databases. Specifically, to better understand how a web application works and how to program that application, it will go from

the level of web browser and HTTP protocols, to how the application itself works, that is, the programming languages. from the server and link to the database.

PHP is the abbreviation for Hypertext Preprocessor. It is a scripting language used for web application development. By the scripting language, we mean a program that is written based on script (lines of code) for task automation [5].

Web pages can be designed using HTML. With HTML, code execution is done on the user's browser (on the client side). On the other hand, on the server, PHP is executed before it reaches the user's web browser.

It can be embedded in HTML and is suitable for web development and dynamic web page creation for web applications, e-commerce applications and database applications. It is considered a friendly language with the ability to easily connect to MySQL, Oracle and other databases [6].

Perl is a dynamic programming language and its main purpose is to improve the processing time of a report or text (RegEx [7]). The acronym comes from the words "Practical Extraction and Reporting Language". It runs on a variety of platforms, such as Windows, Mac OS, and various versions of UNIX [8].

Perl can be implemented in many areas. The most popular use of Perl is in web development. Perl is also used to automate multiple tasks in web servers, and server administration can automatically generate emails and cleaning systems. Perl is still used for the initial purpose, ie extracting data and generating reports. It can produce reports on resource usage and verify network security issues.

For this reason, Perl has become a language widely used in web development, networking and bioinformatics. Apart from this, the language can also be used for CGI programming.

Java is a high-level programming language originally developed by Sun Microsystems and launched in 1995. Java runs on a variety of platforms, such as Windows, Mac OS, and various versions of UNIX.

Like any programming language, Java has its own structure, syntax rules and programming paradigm. The Java language programming paradigm is based on the concept of OOP, which the language functions support.

Java is a derivative of C, so the rules of its syntax look very similar to C. For example, blocks of code are modulated in methods and delimited by braces ({and}), and variables are declared before being used.

Cascading style sheets, abbreviated CSS, are a simple design language designed to simplify the process of presenting web pages.

CSS deals with the appearance of a web page. Using CSS, you can control the text color, font style, paragraph spacing, how columns are sized and arranged, what background or color images are used, layout patterns, display variations for different devices, and screen sizes as well as a variety of other effects.

CSS is easy to learn and understand and offers increased control over the presentation of an HTML document. Most commonly, CSS is combined with HTML or XHTML markup languages.

JavaScript is a scripting language used to create and control the dynamic content of the site.

To better understand, a few examples would be the features of a website such as animated graphics, photo slideshows, autocomplete text suggestions and interactive forms. In these examples, JavaScript is used.

A data set is an elaborate grouping of data, normally electronic systems can be introduced and accessed. As databases are more comprehensive, they are needed to develop formal design and modeling techniques.



Database Management System (DBMS) is a care software communicated with end-users, application applications and the database itself for automatic occupancy and analysis. The software includes DBMS in addition to features provided to provide database management services. The total amount of a database, DBMS, and terminals can be called a "database system." Often, the term "is a date" is also used for a face naturally referred to any DBMS, may have a database or an application attached to the database.

Formulations, possibility and efficiency of databases and a DBMS have increased over time. To optimize performance options and to provoke evolutionary techniques in the areas of processing, computer memory, computer storage and computer networks.

Databases and DBMSs can be arranged depending on the model or models of care data that supports (such as relational being or XML), types of computers that take care of functioning (from one cluster server to one). cell phone) query languages for database access (such as SQL or XQuery) and their internal engineering, care affects performance, scalability, resilience and security.

MySQL is a database-based system for managing databases while Oracle care is the foundation of Structurad Query Language. MySQL regulates almost all platforms, including Linux and Windows. It can be used for a wide range of applications, MySQL is most often associated with web applications and online publications.

### **3. THE APPLICATION**

In this part the application itself will be presented along with all the functions and functionalities that the application offers. This chapter will include class diagrams, application architecture as well as application usage diagrams.

The purpose of the project is to make it easier for people who want to pursue a military career to obtain information. Also, people who are already familiar with this area can view the ads page where different news and information about military events as well as those of foreign diplomacy or national security will be posted.

This software application is designed to help new applicants to military technical colleges and current students who need information about certain military equipment and about low prices or discounts on military equipment.

#### **3.1. General description of the application**

This subchapter represents the entire system. The server-client interactions between the application and the user / administrator will be presented. At the end of the chapter, some constraints and dependencies of the current system will be presented.

##### **3.1.1. Product perspective**

In terms of architecture it is an application on several layers as in Figure 8. Each layer communicates only with those closest to it, being robust and isolated for each layer separately. Layer isolation refers to the fact that a change made in a layer does not affect any other layers. If direct presentation would be allowed from the presentation layer to the persistence layer (which only involves SQL queries), then the following changes will affect both presentation and business thus resulting in close coupling with many component interdependencies. Such an application becomes difficult to modify and maintain.

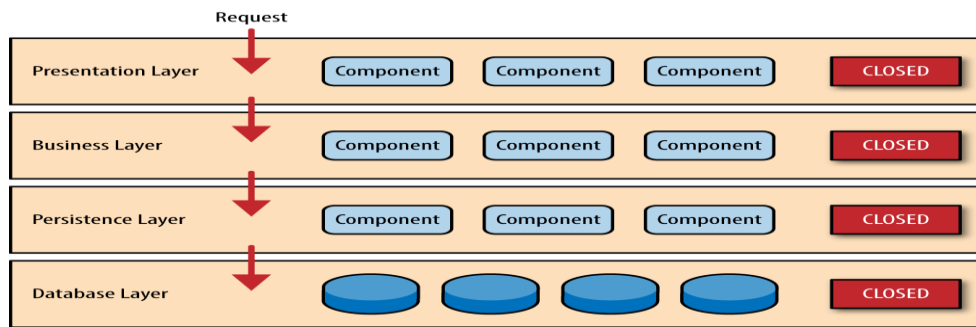

Figure 1. Separation of the architecture in 4 layers

The application is divided into three main states:

- Presentation Layer
- Business Layer
- Persistence Layer

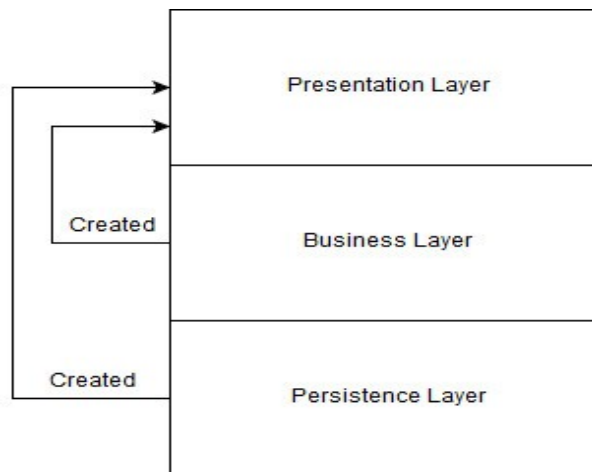

Figure 2. Application architecture

The presentation layer is the part where the application is displayed and rendered. This is where the application runs when the user enters pages such as the home page and / or other pages of the application.

Business layer is the computing part of the application. The user is allowed to add only alphanumeric characters in certain inputs, for example to the user and password if it is the login page. Here, too, string splits, mathematical calculations or other logical operations are related to the application.

The last layer is the persistence layer where requests are made on the database. For example, selections, additions, changes, or deletions will enter this layer. Even though the database layer is an important component, we can include it in the persistence layer part because it only links to the database (this is a single class).

You can see in Figure 2 that the business and persistence layer are initialized in the presentation layer, because the creation of a database instance will be done at the top of the page. The reuse of the court is done by sending to the constructor any other class that needs this court.

The diagram below - Figure 3, further details the components inside each layer, for a better understanding of the application.

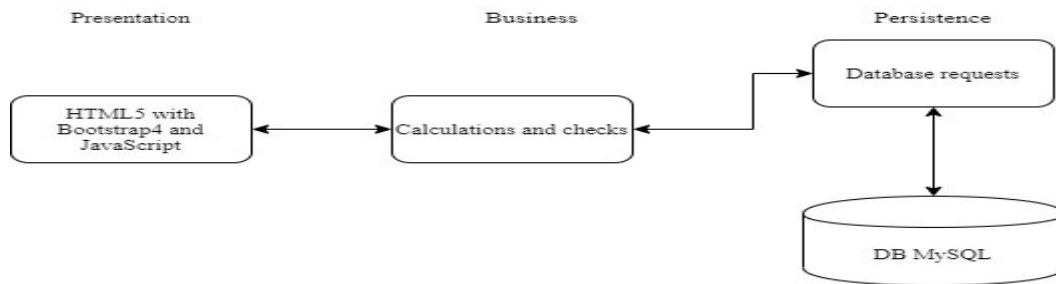

Figure 3. Example of application architecture

Presentation layer being the UI part of the application that contains HTML5, Bootstrap 4 and some parts of JS (mainly on the administration side).

Business layer, as we presented above, is the place where the correctness of the added data is verified, with the back-end functions with PHP 7 which are put over the entered texts and mathematical calculations (used for the administration part where the charts are).

Persistence layer is composed of the connection of the MySQL database with PHP and the queries on this database.

### 3.2. Product functions

The pages that the user can view are exactly the data in the database added from the management panel by the moderator / administrator. Moderation of the pages is done only from the management panel by authorized persons. Adding, editing, and deleting ads is all done in the admin panel. In addition, there is a page with statistics represented in the form of charts and the page with all the moderators and administrators existing on the application. Adding other moderators is done only by administrators. These functionalities are shown in diagram form in Figure 4.

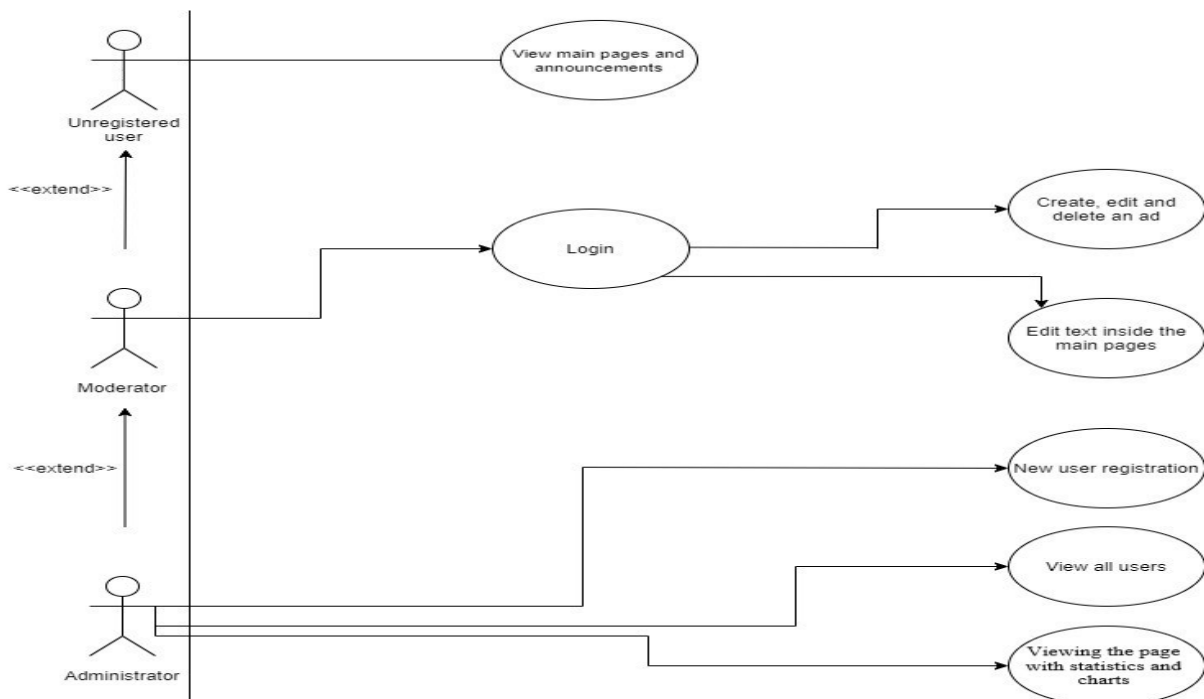

Figure 4. Use case diagram

Characteristics of uses

There are three types of users:

- Unauthorized users

- Users authenticated as moderators
- Users authentication as administrators

### 3.3. Assumptions and addictions

The application depends on a careful text editor you can edit information about each page including ads. With this software you create in JS you can write HTML with emphasis on certain words and you can see mistakes easier. You can do save, new file, load, search, font size and more.

## 4. CONCLUSION

The application is separated by layers because each layer works without knowing another layer and thus they are not coupled by data, methods or classes. The persistence part only deals with queries on the database, the business layer or heart of the application performs sorting, checking, searching and the presentation part only displays the received data. The only connection is made between the presentation layer and the persistence layer because the connection with the database is instantiated on the current PHP page.

It is beneficial to reuse the connection with the database in order to avoid problems on the server. For each page accessed, there is only one connection to the database, it is used in all classes on that page and it is closed at the end.

Connections open on the database and not closed in time opt for ports. Ports remain open, no other connection can be made to that port, and restarting the server is not an optimal solution (in case the web application is on a server where there are tens / hundreds of other applications running simultaneously) .

The application has a major impact on students who plan to learn more about their military career. The main pages provide information on all that pertains to a future military career. The news is updated daily and so the average age of the public will not only represent the students and students, but also the current military or even civilians. The ads page provides an addition to the current application because this page is intended for a wider audience to inspect and read new information.

## REFERENCES

- [1] Consorțiul Web este un consorțiu internațional, format din membri permanenți și parteneri, care are ca scop dezvoltarea de standarde pentru World Wide Web.
- [2] Sabin Buraga, *Aplicatii Web la cheie. Studii de caz implementate in PHP*, Polirom, 2003, p.33.
- [3] C. Mîndruță, *Arhitecturi, tehnologii și programare în Web*, Ed. MATRIX ROM, 2005. p.53.
- [4] Adobe ColdFusion este o platformă comercială de dezvoltare rapidă a aplicațiilor web creată de J. J. Allaire în 1995. ColdFusion a fost conceput inițial pentru a facilita conectarea paginilor HTML simple la o bază de date.
- [5] <http://php.net/manual/ro/intro-what-is.php>
- [6] L. Alboaic, S. Buraga, *Servicii Web. Concepte de bază și implementări*, Polirom, 2006, p. 196.
- [7] Reprezintă o expresie regulată (din engleză – regular expression), care definește un șablon de căutare. Pe baza acestui șablon se pot aplica operațiuni de înlocuire și/sau căutare.
- [8] <https://www.guru99.com/perl-tutorials.html>

## BIBLIOGRAPHY

- Alina-Florentina Ciltan, JavaScript, Else, 2016.
- C. J. Date, An Introduction to Database Systems, Pearson, 2003.

C. Mîndruță, Arhitecturi, tehnologii și programare în Web, Editura MATRIX ROM, 2005.  
L. Alboaic, S. Buraga, Servicii Web. Concepte de bază și implementări, Polirom, 2006.  
Sabin Buraga, Aplicații Web la cheie. Studii de caz implementate în PHP, Editura Polirom, 2003.  
Sabin Buraga: 'Proiectarea siturilor Web – ediția a doua', Editura Polirom, 2005.

# OPTIMIZATION OF MILITARY ACTIONS USING DECISION-MAKING METHODS

Ionuț Vlad ZOTICĂ

“Nicolae Bălcescu” Land Forces Academy, Sibiu

zotica.vlad@yahoo.com

Scientific coordinator: Assist.Prof. Alina BABOȘ, PhD

**Abstract:** *Mathematics is a science that studies structural, change and space models that create methods and models that bring general computation modalities, and when mathematical models are based on real phenomena, mathematical reasoning can provide information or predictions about nature. Because the identification of optimal solutions in the problems related to the decision making under conditions of certainty and in conditions of uncertainty can be difficult the mathematicians have developed different methods. The use of such methods is necessary and very useful for commanders in identifying the optimal variant that supports the process of substantiating decisions in various situations such as equipping troops with technique and equipment or selecting the most appropriate type of device for missions, tasks or various situations.*

**Keywords:** decision-making, software, submachine guns

## About D-Sight

In order to identify optimal solution, D-Sight software will be used, an online project portfolio management platform focused on early stage decision making that provides support for decisions and related services in the areas of project prioritization, supplier selection and collaborative decision making.

Being a software program running in the browser, for its use, an active Internet connection is required. The program allows the user to collect and centralize the data for analysis, to evaluate the alternatives, to compose a ranking and to prioritize the proposals, to allocate the resources of those variants that bring the highest value to the organization.

Entering the data needed to perform the analysis is done using the elements listed below:

Project wizard is a configuration software assistant that presents to the user a series of windows in which the information offered for analysis is introduced. Also, the software offers the user the possibility to enter the data to be entered into the analysis process directly from a file with the extension .xlsx using the Import from Excel tab.

Alternatives window allow the use of a variant of name according to the care can be analyzed and an erroneous number must be extended through the Add and Remove tabs and the obligation to enter at least two such numbers.

The Criteria window allows the user to add the name of the criteria considered in the analysis. It is also possible to delete a possible name entered incorrectly through the Remove tab.

With the help of the Parameters window the user can choose the character of each criterion separately, this can be one of maximum or one of minimum.

In the Weights window the user has the possibility to assign each criterion to specific weights according to which the analysis of variants will be completed later, or he can choose to assign equal weights to all criteria using the Set All Weights Equal tab.

Evaluations window is the one in which the user enters or imports from a file with the extension .xlsx the data of each alternative in relation to each criterion separately for analysis.

The navigation between the configuration assistant windows is done using the Next and Previous tabs, and once the user enters the data and in the last window the analysis starts through the Setup Project tab.

The last window, Analysis offers the user a variety of tools for ranking, visual analysis, profiling and analysis by differentiating the criteria with which one can easily identify the optimal alternative.

**Introducing the problematic situation**

In order to fulfill a specific mission outside the country's borders, a military unit, with CQC (*Close Quarters Combat*) capabilities and responsibilities, has five types of SMG (*Submachine Guns*) available to choose from.

The alternatives and the criteria according to which the analysis will be done are:

- A<sub>1</sub> – Heckler & Koch MP5, Germany;*
- A<sub>2</sub> – FN P90, Belgium;*
- A<sub>3</sub> – Heckler & Koch UMP, Germany;*
- A<sub>4</sub> – Brugger & Thomet APC9, Switzerland;*
- A<sub>5</sub> – X95, Israel,*

- C<sub>1</sub> – muzzle velocity, [m/s];*
- C<sub>2</sub> – weight, [kg];*
- C<sub>3</sub> – range of effective fire, [m];*
- C<sub>4</sub> – magazine capacity, [rounds];*
- C<sub>5</sub> – practical rate of fire, [rounds/min].*

**Use of D-Sight in the decision making process**

After the names of the alternatives have been introduced and the criteria according to which the analysis will be completed, the next step is to setup the weights for each criterion separately, according to mission requirements, as follows in (Figure 1):

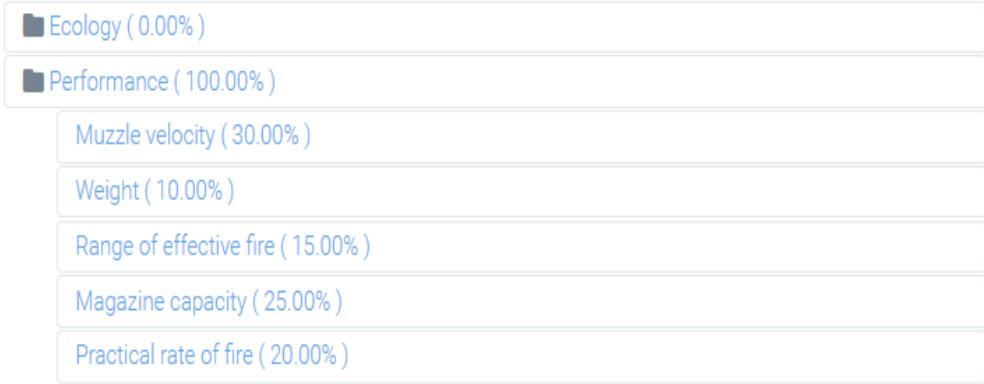

Figure nr. 1 *Criteria Weighting*

The weight of each criterion was established taking into account mission requirements. For example the decision factor considers that the muzzle velocity of a submachine gun have a high impact on the result of the mission, therefore muzzle velocity criteria was assigned the highest value.<sup>1</sup>

The technical characteristics of each alternative according to which the analysis will be performed are presented in (Figure 2)<sup>23</sup>:

	Muzzle velocity	Weight	Range of effective fire	Magazine capacity	Practical rate of fire
Heckler & Koch MP5	400.0	2.9	100.0	30.0	120.0
FN P90	700.0	2.5	200.0	50.0	100.0
Heckler & Koch UMP	285.0	2.3	100.0	25.0	80.0
Brugger & Thomet APC9	330.0	2.7	75.0	30.0	100.0
X95	330.0	3.4	100.0	32.0	120.0

Figure nr. 2 Evaluate alternatives

The last and most important step in decision-making using D-Sight software is the analysis stage. The results are presented in the following figures:

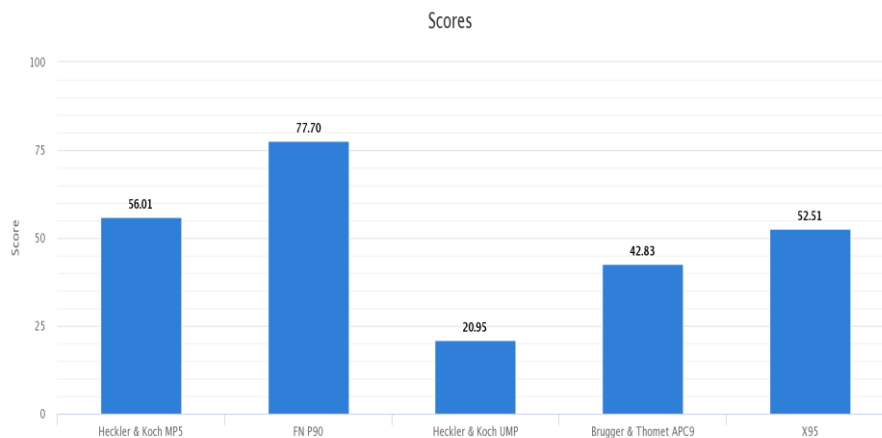

Figure nr. 3 Scores

After performing the analysis, the D-Sight software places FN P90 in the first position, with a score of 77.7, thus being the most suitable alternative. In the second place is the MP5 alternative with a score of 56.01, which will be considered a reserve alternative for the purpose of the mission.

In the (Figure 4) is presented a spider web diagram of the best alternative and the reserve alternative in which it is observed that the *Heckler & Koch MP5* reserve alternative exceeds the main alternative *FN P90* at practical rate of fire criterion.<sup>4</sup>

[1] Vasile Căruțașu and Alina Baboș, *Culegere de probleme și cercetări operaționale*, (Sibiu: "Nicolae Bălcescu" Land Forces Academy Press, 2016), 222.

[2] G. Calopăreanu, *Metode, tehnici și modele de optimizare a deciziilor la structurile militare operaționale multinaționale*, (București: CTEA Press, 2008), 95.

[3] <http://www.military-today.com/firearms.htm>

<sup>4</sup> <https://web.d-sight.com/>



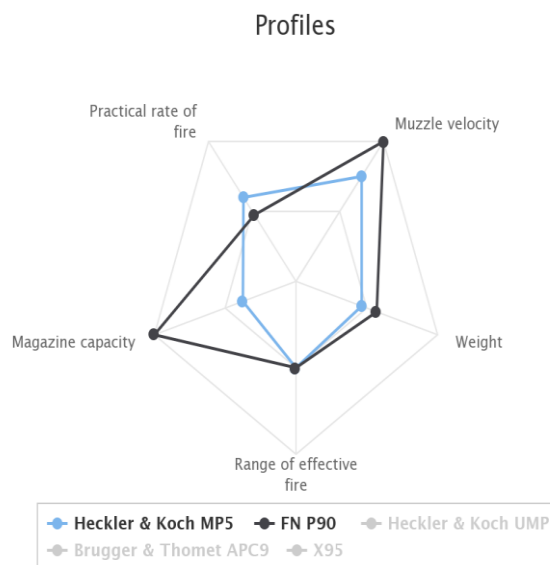

Figure nr. 4 Profiles

### Conclusions

Finally, it may be concluded that *FN P90* is the most suitable submachine gun for the purpose of current mission, followed by *Heckler & Koch MP5* as a reserve alternative and *X95* as a third option.

The scope of using the decision-making methods is much wider, being encountered in social, technological, military or administrative activities, and the D-Sight software products, guarantee the correct decision to be implemented in a system.

### BIBLIOGRAPHY

Vasile Căruțașu and Alina Baboș, *Culegere de probleme și cercetări operaționale*, Sibiu: "Nicolae Bălcescu" Land Forces Academy Press, 2016

G. Calopăreanu, *Metode, tehnici și modele de optimizare a deciziilor la structurile militare operaționale multinaționale*, București: CTEA Press, 2008

Mircea Andreiașu, Aurora Baci, Anca Pașcu, Elena Pușcaș, Alexandru Tașnadi, *Metode de decizii multicriteriale*, București: Tehnica Press, 1986

D. Lyras, Elliot Soloway, and Roger Schank, *The Future of Decision Making: How Revolutionary Software Can Improve the Ability to Decide*, New York: Palgrave Macmillan Press, 2010.

Stuart S. Nagel, *Decision aiding-software: Skills, Obstacles and Applications*, New York: St. Martin's Press, 1991.

<http://www.military-today.com/firearms.htm>

<https://web.d-sight.com/>